

FINAL



Recharge and Recirculation Edwards Aquifer Optimization Program

Phase III/IV Report

Prepared for the Edwards Aquifer Authority
December 2008

Prepared by:

TODD

Todd Engineers
2490 Mariner Square Loop, Suite 215
Alameda, CA 94501

In association with:



TRC/Brandes
505 East Huntland Drive, Suite 250
Austin, TX 78752



NRS Engineering
919 Congress Avenue, Suite 460
Austin, TX 78701

Table of Contents

Executive Summary	ES-1
1. Introduction.....	1
1.1. Background.....	1
1.2. Purpose and Goals	2
1.2.1. Springflow Maintenance.....	3
1.2.2. Sustainable Yield.....	3
1.3. Scope of Work.....	4
1.4. Use of Numbers	5
1.5. Acknowledgements	5
2. Concepts of Recirculation.....	2-1
2.1. Previous Investigations on R&R Strategies	2-4
2.1.1. Recharge Enhancement Studies	2-4
2.1.2. Recirculation Studies	2-7
2.1.3. Todd Engineers R&R Phases I and II	2-8
2.2. EAA Rules	2-9
2.2.1. Critical Period Management (CPM) Rules	2-9
2.2.2. Aquifer Recharge, Storage, and Recovery (ARSR) Rules.....	2-10
2.3. Application of the USGS MODFLOW Model	2-11
3. Baseline Scenario Development	3-1
3.1. Modifications to EAA Model.....	3-1
3.1.1. Well File Modification.....	3-1
3.1.2. Initial Water Levels.....	3-4
3.1.3. Amended Critical Period Management Rules	3-4
3.1.4. Resolution of Dry Cells in the Model.....	3-6
3.1.5. Representative Hydrologic Conditions.....	3-7
3.2. Results of Baseline Scenario	3-9
4. Preliminary Groundwater Model Runs	4-1

4.1.	Evaluation of Enhanced Recharge at Type 2 Sites.....	4-1
4.1.1.	Evaluation of One Time (Slug) Recharge at Type 2 Sites.....	4-2
4.1.2.	Evaluation of Annual Recharge at Type 2 Sites.....	4-6
4.2.	Evaluation of Minimum Springflow.....	4-9
4.2.1.	Minimum Springflow During Dry Conditions.....	4-10
4.2.2.	Minimum Springflow During Average Conditions.....	4-11
5.	Source Water Availability	5-1
5.1.	Surface Water	5-1
5.1.1.	Application and Modifications of Water Availability Models.....	5-4
5.1.2.	GSA Basin R&R Source Water.....	5-11
5.1.3.	Nueces Basin R&R Source Water	5-15
5.2.	Unused Edwards Aquifer Permits.....	5-17
5.3.	Excess Springflow from Recirculation.....	5-21
6.	Evaluation of Potential R& R Components.....	6-1
6.1.	Description of Components.....	6-1
6.1.1.	Type 2 Recharge Sites.....	6-4
6.1.2.	Guadalupe River Diversions.....	6-5
6.1.3.	Recirculation of Excess Springflow.....	6-5
6.1.4.	Pumping of Unused Withdrawal Rights	6-6
6.1.5.	Selection of A Type 1 Recharge Structure	6-7
6.2.	Application of Source Water Data	6-8
6.2.1.	Unappropriated and Marketable Estimates	6-8
6.2.2.	Unused Withdrawal Permits.....	6-9
6.3.	Sizing of Recharge Structures and Pipelines.....	6-9
6.3.1.	Sizing of Recharge Structures.....	6-10
6.3.2.	Sizing of Pipelines.....	6-12
6.4.	Component Modeling Results	6-13
6.4.1.	Enhanced Recharge at Type 2 R&R Sites.....	6-13
6.4.2.	Enhanced Recharge with Guadalupe (and other) River Diversions.....	6-20
6.4.3.	Recirculation of Excess Springflow	6-24
6.4.4.	Enhanced Recharge using Groundwater from Unused Permits.....	6-26
6.4.5.	Enhanced Recharge with Type 1 Structures	6-27

6.5.	Component Evaluations Summary and Costs.....	6-29
6.5.1.	Component Yield.....	6-31
6.5.2.	Component Costs.....	6-31
6.5.3.	Combining Components into Scenarios	6-32
7.	Recharge and Recirculation Scenarios	7-1
7.1.	Scenario 1	7-2
7.1.1.	Development of Recovery Factors.....	7-4
7.1.2.	Scenario 1a (without Enhanced Pumping)	7-6
7.1.3.	Scenario 1b (with Enhanced Pumping).....	7-7
7.1.4.	Results of Scenario 1b.....	7-7
7.2.	Scenario 2	7-8
7.2.1.	Description	7-9
7.2.2.	Results of Scenario 2	7-9
7.3.	Scenario 3.....	7-10
7.3.1.	Description.....	7-10
7.3.2.	Results of Scenario 3	7-11
7.4.	Scenario 4.....	7-13
7.4.1.	Description.....	7-13
7.4.2.	Results of Scenario 4	7-14
7.5.	Scenario 5.....	7-15
7.5.1.	Description.....	7-15
7.5.2.	Results of Scenario 5	7-15
7.6.	Scenario No. 6.....	7-17
7.6.1.	Description.....	7-17
7.6.2.	Results of Scenario 6	7-18
7.7.	Scenario No. 7	7-19
7.7.1.	Description.....	7-19
7.7.2.	Results of Scenario 7	7-20
7.8.	Scenario Summary	7-21
7.9.	Facilities Costs	7-24
7.10.	Drought Yield	7-25
7.11.	Optimizing Considerations.....	7-28

8. Conclusions and Recommendations.....	8-1
8.1. Conclusions.....	8-1
8.2. Recommendations and Limitations.....	8-4
9. References	9-1
10. Definition of Terms.....	10-1

List of Tables

Table 2-1: Recommended Recharge Enhancement Program for the Nueces River Basin ...	2-5
Table 2-2: Recommended Recharge Enhancement Program for the Guadalupe-San Antonio (GSA) River Basin	2-6
Table 2-3. EAA Critical Period Management (CPM) Rules.....	2-10
Table 3-1: Distribution of Annual Pumping on a Monthly Basis by Water Use.....	3-3
Table 3-2: Withdrawal Reductions under CPM Rules As Amended by S.B. 3	3-5
Table 3-3: Representative Hydrologic Conditions.....	3-8
Table 4-1: Results of Slug Recharge 1947-1973	4-3
Table 4-2: Results of Slug Recharge 1974-2000	4-3
Table 4-3: Aquifer Retention Time for 1947 Slug Recharge.....	4-5
Table 4-4: Aquifer Retention Time for 1974 Slug Recharge.....	4-5
Table 4-5. Results of Enhanced Annual Recharge 1947-1973.....	4-6
Table 4-6. Results of Enhanced Annual Recharge 25,000 AFY 1974-2000.....	4-7
Table 4-7. Results of 25,000 AFY Enhanced Recharge as Percent Applied (1946-1973).....	4-8
Table 4-8. Results of 25,000 AFY Enhanced Recharge as Percent Applied (1974-2000).....	4-8
Table 4-9: Aquifer Retention Time for 25,000 AFY Recharge 1947-1973	4-9
Table 4-10: Aquifer Retention Time for 25,000 AFY Recharge 1974-2000	4-9
Table 4-11. Annual Enhanced Recharge to Maintain Comal Springs Flow for Dry and Average Conditions.....	4-10
Table 5-1: Summary of Regressions of Unappropriated Water with Gaged Flow	5-11
Table 5-2: GSA WAM Control Point Assignments for R&R Sites in the GSA Basin.....	5-12
Table 5-3: Summary of Unappropriated Water for Potential R&R Sites in the GSA Basin (AF)	5-13
Table 5-4: Summary of Marketable Water for Potential R&R Sites in the GSA Basin (AF).....	5-14
Table 5-5: Nueces WAM Control Point Assignments for R&R Sites in the Nueces Basin...	5-15
Table 5-6: Summary of Unappropriated Water for Potential R&R Sites in the Nueces Basin (AF).....	5-16

Table 5-7: Summary of Marketable Water for Potential R&R Sites in the Nueces Basin (AF)	5-17
Table 5-8: Average Amounts of Unused Pumping Permits by County and Water Use	5-18
Table 6-1: List of Potential R&R Components	6-2
Table 6-2: Comparison of Source Water for the Phase III Study to Previous Studies	6-10
Table 6-3: Yield as Percent of Enhanced Recharge at Type 2 Recharge Sites	6-16
Table 6-4: Yield as Percent of Enhanced Recharge at Type 2 Sites without the Lower Blanco Recharge Site	6-17
Table 6-5: Yield from Type 2 Enhanced Recharge Program with and without the Lower Blanco Recharge Site	6-17
Table 6-6: Average Enhanced Recharge Available at Type 2 Sites	6-18
Table 6-7: Percent Difference between HDR Recharge and WAM-Generated Recharge at Type 2 Sites	6-19
Table 6-8: Percent Difference between HDR Recharge and WAM-Generated Recharge at Type 2 Sites without Lower Blanco	6-20
Table 6-9: Comparison of Yield between Lower Verde/Lower Hondo and San Geronimo Recharge Sites for Comfort/Medina Source Water	6-22
Table 6-10: Comparison of Benefits between Cibolo Recharge Site and San Geronimo Recharge Site for Dunlap Source Water	6-23
Table 6-11: Comparison of Benefits between Canyon Lake and Lake Dunlap Diversion Sites to Cibolo Type 2 Recharge Site	6-24
Table 6-12: Yield for Enhanced Recharge and Excess Springflow Recirculation and the Percent Difference	6-25
Table 6-13: Total Yield from Unused Permits	6-27
Table 6-14: Comparison of Yield from Recharge in a Type 1 Recharge Structure (timed release) and a Type 2 Recharge Structure (recharged as available)	6-28
Table 6-15: Comal Springs Comparison of Type 1 and Type 2 Recharge	6-28
Table 6-16: R&R Components - Yield and Costs	6-30
Table 7-1: Summary of R&R Scenarios	7-2
Table 7-2: Recovery Factors – Percent of Recoverable Recharge at Recharge Sites	7-5
Table 7-3: Scenario 1a without Enhanced Pumping	7-6
Table 7-4: Scenario 1a without Enhanced Pumping as Percent of Enhanced Recharge	7-6
Table 7-5: Yield of Scenario 1b	7-7
Table 7-6: Yield of Scenario 1b as a Percent of Enhanced Recharge	7-8
Table 7-7: Yield of Scenario 2	7-9
Table 7-8: Yield of Scenario 2 as a Percent of Enhanced Recharge	7-10
Table 7-9: Yield of Scenario 3 with Enhanced Pumping and Recirculation Pumping	7-12
Table 7-10: Yield of Scenario 3 as a Percent of Enhanced Recharge	7-12
Table 7-11: Yield of Scenario 4	7-14

Table 7-12: Yield of Scenario 4 as a Percent of Enhanced Recharge	7-14
Table 7-13. Annual Average Yield of Scenario 5	7-16
Table 7-14. Yield of Scenario 5 as a Percent of Enhanced Recharge.....	7-16
Table 7-15: Yield of Scenario 6	7-18
Table 7-16: Scenario 6 as a Percent of Enhanced Recharge	7-18
Table 7-17: Yield of Scenario 7	7-20
Table 7-18: Yield of Scenario 7 as a Percent of Enhanced Recharge	7-21
Table 7-19: Comparison of R&R Scenarios	7-22
Table 7-20. Annualized Cost for Scenarios (in millions of dollars)	7-25
Table 7-21. Drought Yield.....	7-27

List of Illustrations

2-1: Example Bar Graph Illustrating the Fate of Recharged Water.....	2-2
2-2: Types of Recharge Structures.....	2-3
3-1: Original Pumping from the MODFLOW Model	3-2
3-2: Monthly Distribution of Pumping by Water Use	3-3
3-3: Comal Springflow under Original and Baseline Conditions.....	3-10
5-1: Unused Withdrawal Permits.....	5-19
5-2: Precipitation at Selected Stations across the Edwards Aquifer	5-20

List of Figures (following text)

1-1. Study Area with R&R Recharge Sites	
3-1. Pumping Totals under CPM Rules	
3-2. Representative Hydrologic Cycles	
3-3. Baseline Scenario – Comal and San Marcos Springs	
3-4. Baseline Scenario – Water Levels in J-17 and J-27	
4-1. Results of Slug Recharge Analysis	
4-2. Retention Time of Slug Recharge	
4-3. Results of 25,000 AFY Annual Recharge	
4-4. Retention Time of Annual Recharge	
4-5. Enhanced Recharge Required for Minimum Springflow of 40 cfs for Dry Conditions	
4-6. Enhanced Recharge Required for Minimum Springflow of 150 cfs for Dry Conditions	
4-7. Enhanced Recharge Required for Minimum Springflow of 150 cfs for Average Conditions	
5-1. Source Water Sites	
6-1. R&R Components	
6-2. Histograms of the Unappropriated Water at Dunlap and Canyon Sites	
6-3. Histograms of the Unappropriated Water at Comfort and Medina River	

- 6-4. Unappropriated and Marketable Water for Type 2 R&R Sites
- 6-5. Unappropriated Water for the Central Type 2 Sites (Lower Frio to Lower Verde)
- 6-6. Total Yield from Type 2 Enhanced Recharge (Maximum Available Source Water)
- 6-7. Total Yield from Type 2 Enhanced Recharge (Unappropriated Water)
- 6-8. Recharge Remaining in the Aquifer over Time, Indian Creek
- 6-9. Recharge Remaining in the Aquifer over Time, Lower Frio
- 6-10. Recharge Remaining in the Aquifer over Time, Lower Sabinal
- 6-11. Recharge Remaining in the Aquifer over Time, Lower Hondo
- 6-12. Recharge Remaining in the Aquifer over Time, Lower Verde
- 6-13. Recharge Remaining in the Aquifer over Time, San Geronimo
- 6-14. Recharge Remaining in the Aquifer over Time, Cibolo Dam
- 6-15. Recharge Remaining in the Aquifer over Time, Lower Blanco
- 6-16. Total Yield Enhanced Recharge at All Type 2 Sites
- 6-17. Total Yield Enhanced Recharge Type 2 Sites (Excluding Lower Blanco)
- 6-18. Total Yield of Type 2 Enhanced Recharge with HDR Source Water Estimates
- 6-19. Total Yield of Type 2 (excluding Lower Blanco) Enhanced Recharge with HDR Source Water Estimates
- 6-20. Total Source Water for Enhanced Recharge at Type 2 Sites with Excess Springflow
- 6-21. Yield of Excess Springflow Recirculation

- 7-1. Enhanced Recharge, Scenarios 1, 2, and 5
- 7-2. Recovery Factors for Various Recharge Sites
- 7-3. Results of Scenario 1a without Enhanced Pumping
- 7-4. Results of Scenario 1b with Enhanced Pumping
- 7-5. Results of Scenario 2
- 7-6. Enhanced Recharge for Scenarios 3 and 4
- 7-7. Scenario 3 Enhanced Pumping and Recirculation Pumping
- 7-8. Results of Scenario 3 with Enhanced/Recirculation Pumping
- 7-9. Scenario 4 Enhanced Pumping and Recirculation
- 7-10. Results of Scenario 4
- 7-11. Results of Scenario 5
- 7-12. Range of Possible Excess Springflow for Recirculation
- 7-13. Enhanced Recharge for Scenario 6
- 7-14. Results of Scenario 6
- 7-15. Enhanced Recharge for Scenario 7
- 7-16. Results of Scenario 7
- 7-17. Scenario 7 Enhanced Pumping for Recharge Recovery

List of Appendices

- A. Recharge and Recirculation Phase III and Phase IV Scope of Work
- B. Results of Surface Water Modeling
- C. Conceptual Engineering and Cost Estimates

EXECUTIVE SUMMARY

For more than three decades, the Edwards Aquifer Authority (EAA), its predecessor, and others have evaluated groundwater management strategies to more productively use the shared resource of the Edwards Aquifer. These strategies have involved, among others, enhancing natural recharge and recirculating groundwater discharge back into the aquifer system. This study builds on previous investigations and re-evaluates recharge and recirculation (R&R) strategies incorporating:

- analysis with an improved computer flow model,
- updated estimates of available source water, and
- recently-adopted EAA rules for various aspects of aquifer management.

The study also evaluates combinations of strategies and provides preliminary costs for facilities to support implementation of an R&R program. Benefits to the region are evaluated in terms of increased water supply and maintaining minimum springflow at key springs including Comal and San Marcos springs.

This report is part of Phase IV of various R&R tasks performed by Todd Engineers for EAA. It summarizes previously-reported work on Phases I and II and describes new analyses conducted in Phase III. It is herein referred to as the Phase III/IV report. Our scope of services for this project is provided as Appendix A.

The report is organized into 10 chapters, each of which summarizes a specific component of the work. This Executive Summary is organized around these chapter headings and briefly describes the results. A summary of the report is provided below:

- **Chapter 1** introduces the project and provides goals, objectives, and a scope of work
- **Chapter 2** describes R&R concepts and provides a framework for the analysis
- **Chapter 3** defines baseline conditions against which R&R strategies are evaluated
- **Chapter 4** describes the relative performance of various recharge sites for water supply and maintaining Comal Springs above minimum targets for flow.
- **Chapter 5** evaluates the availability of various source waters for enhanced recharge
- **Chapter 6** describes various R&R components, evaluated separately, for possible inclusion in a regional R&R program.
- **Chapter 7** combines R&R components into regional R&R scenarios, maximizing the amount of water available for recharge
- **Chapter 8** provides conclusions and recommendations
- **Chapter 9** lists references cited and/or reviewed for this study
- **Chapter 10** provides a glossary that defines technical terms used in this report

Recharge sites evaluated in this study are shown on Figure ES-1.

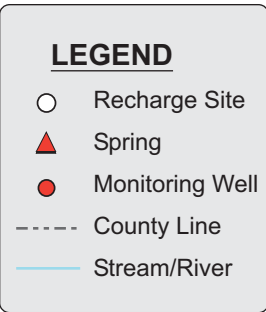
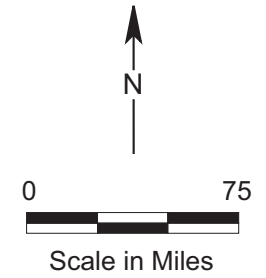

October 2008

TODD ENGINEERS
Alameda, California

Figure ES-1
Study Area With
R&R Recharge Sites

INTRODUCTION (CHAPTER 1)

Chapter 1 introduces the project in the Background section. The goals of springflow maintenance and sustainable yield are described, and the scope of work is summarized.

CONCEPTS OF RECIRCULATION (CHAPTER 2)

Natural infiltration of rainfall and streamflow across the recharge zone of the aquifer provides the source for groundwater that is pumped for water supply and discharged at springs. Increasing the amount of infiltration (enhanced recharge) by capturing storm flows or importing water to the recharge zone has been recognized for decades as a way to increase water supply and springflow. As the enhanced recharge increases groundwater storage, EAA rules allow for an applicant to recover the stored water for use. If the stored water is not needed at certain times, it may be beneficial to return that water to the recharge zone, a concept referred to as recirculation (see Chapter 10 definitions of terms).

To analyze the fate of enhanced recharge as it moves through the aquifer system, this report uses bar graphs indicating locations and quantities of the recharged water at certain times. For example, at some period of time after water has been recharged into the aquifer system, the enhanced recharge is either still in the aquifer system (contributing to groundwater storage) or has been discharged from wells (pumping) or springs (Comal Springs or other springs). A bar graph illustrating this type of analysis is provided below:

Illustration ES-1: Example Bar Graph Illustrating the Fate of Recharged Water

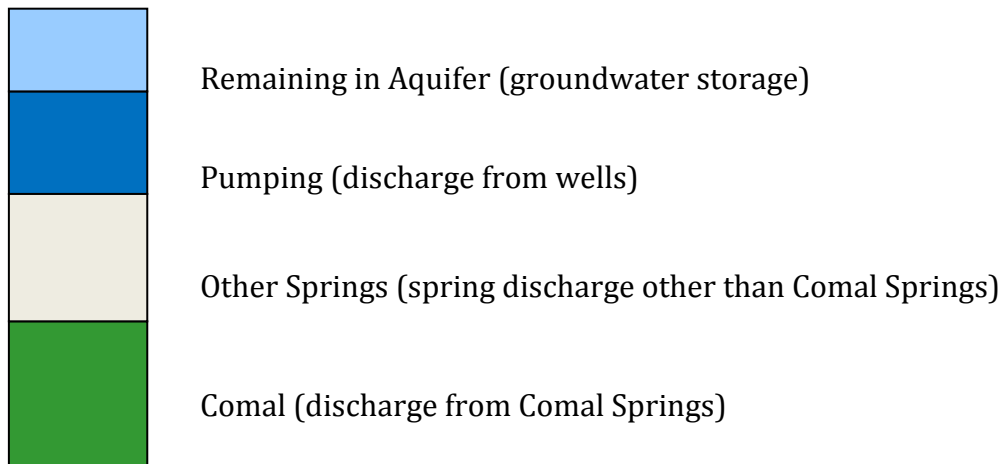

Enhanced recharge requires some type of engineered structure to contain the source water to allow for infiltration. This report evaluates previously-identified sites for recharge referred to as a Type 1 or Type 2 site. A Type 1 site is located upstream of the recharge area and holds water for later release to the recharge zone. A Type 2 site is located on the recharge zone and captures water for direct infiltration. A schematic diagram from previous recharge investigations is provided below illustrating the two types of structures.

Illustration ES-2: Types of Enhanced Recharge Structures

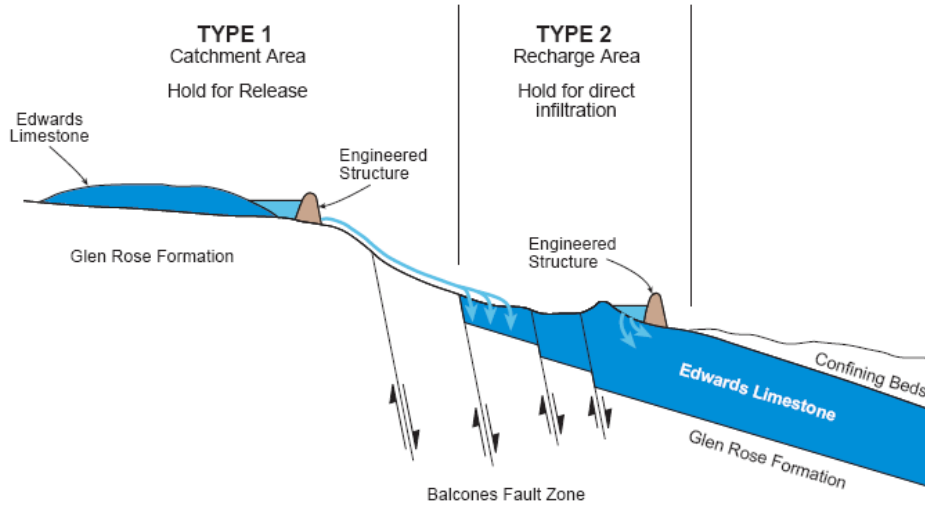

After HDR, et al., 1991

BASELINE CONDITIONS (CHAPTER 3)

For this study, a baseline scenario was developed using the EAA model (covering hydrologic conditions for 1946-2000) and incorporating the recently-amended pumping cap and CPM rules for the model period of record. Pumping for each aquifer pool and CPM reductions are summarized on Table ES-1.

Table ES-1: Withdrawal Reductions under Current CPM Rules for Baseline Scenario

Critical Period Stage	San Antonio Pool		Uvalde Pool		Total Pumping (AFY)
	Pumping (AFY)	Withdrawal Reduction (percent)	Pumping (AFY)	Withdrawal Reduction (percent)	
	448,095		123,905		572,000
I	358,476	20%	123,905	NA	482,381
II	313,666	30%	117,710	5%	431,376
III	291,262	35%	99,124	20%	390,386
IV	268,857	40%	80,538	35%	349,395

Results of the baseline scenario are shown for springflow at Comal Springs and San Marcos Springs (Figure ES-2) and water levels in index wells J-17 and J-27 (Figure ES-3).

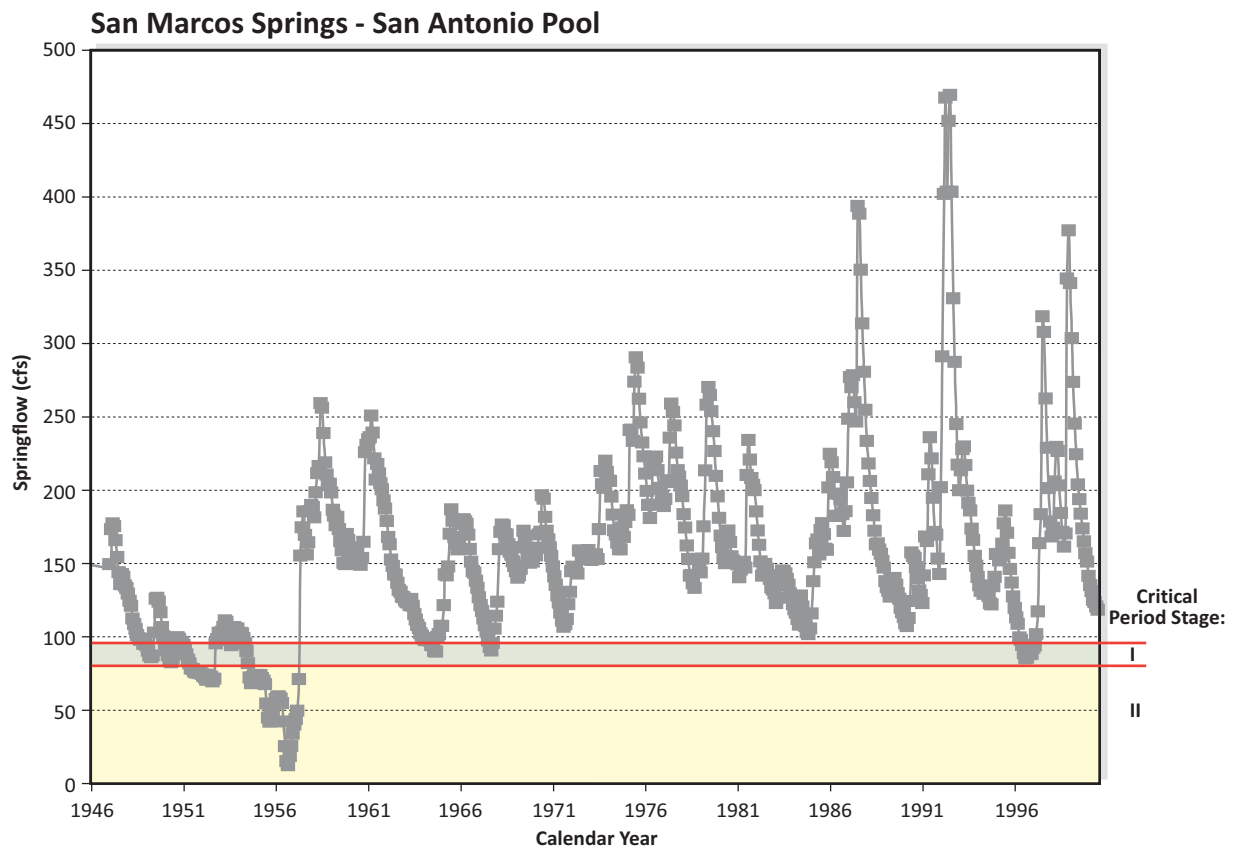
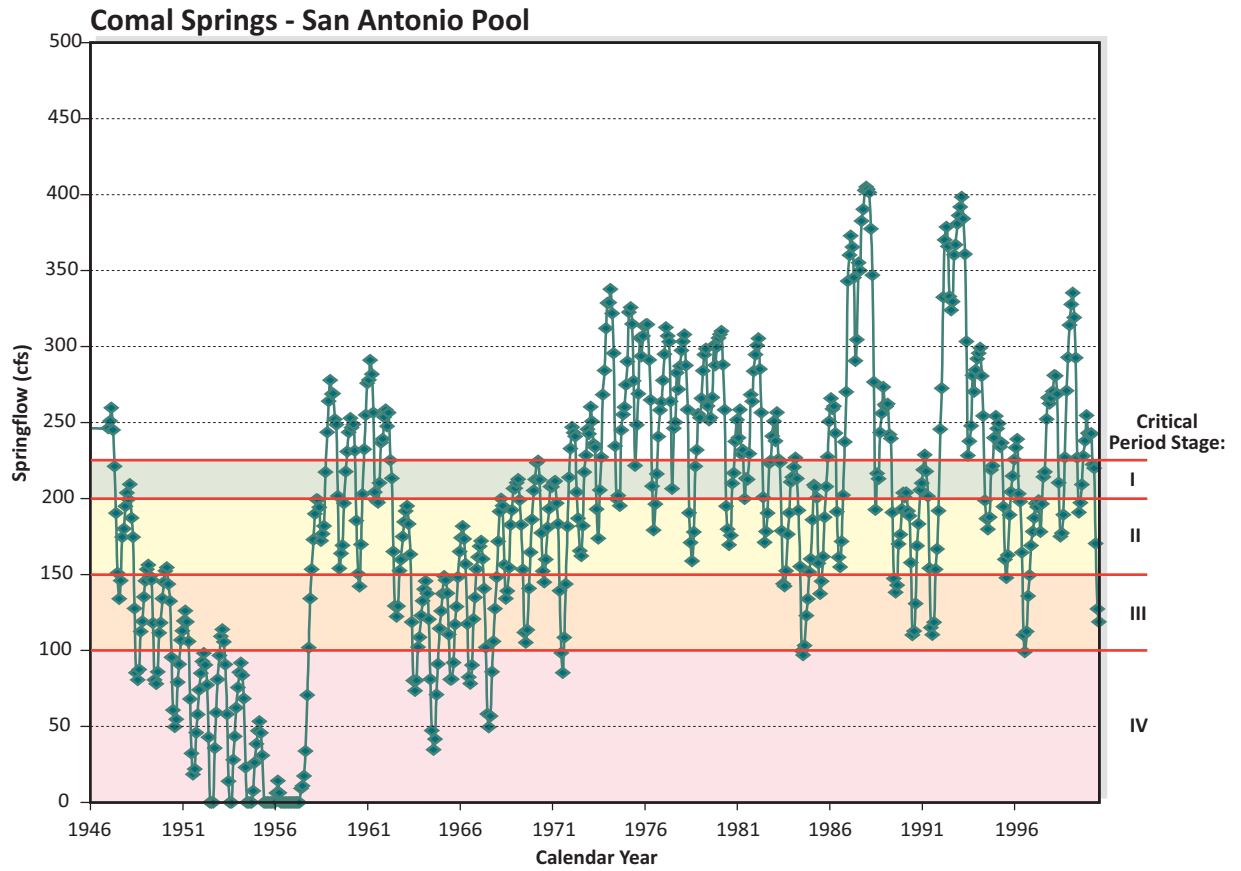

October 2008
TODD ENGINEERS
Alameda, California

Figure ES-2
Baseline Scenario
Comal and
San Marcos Springs

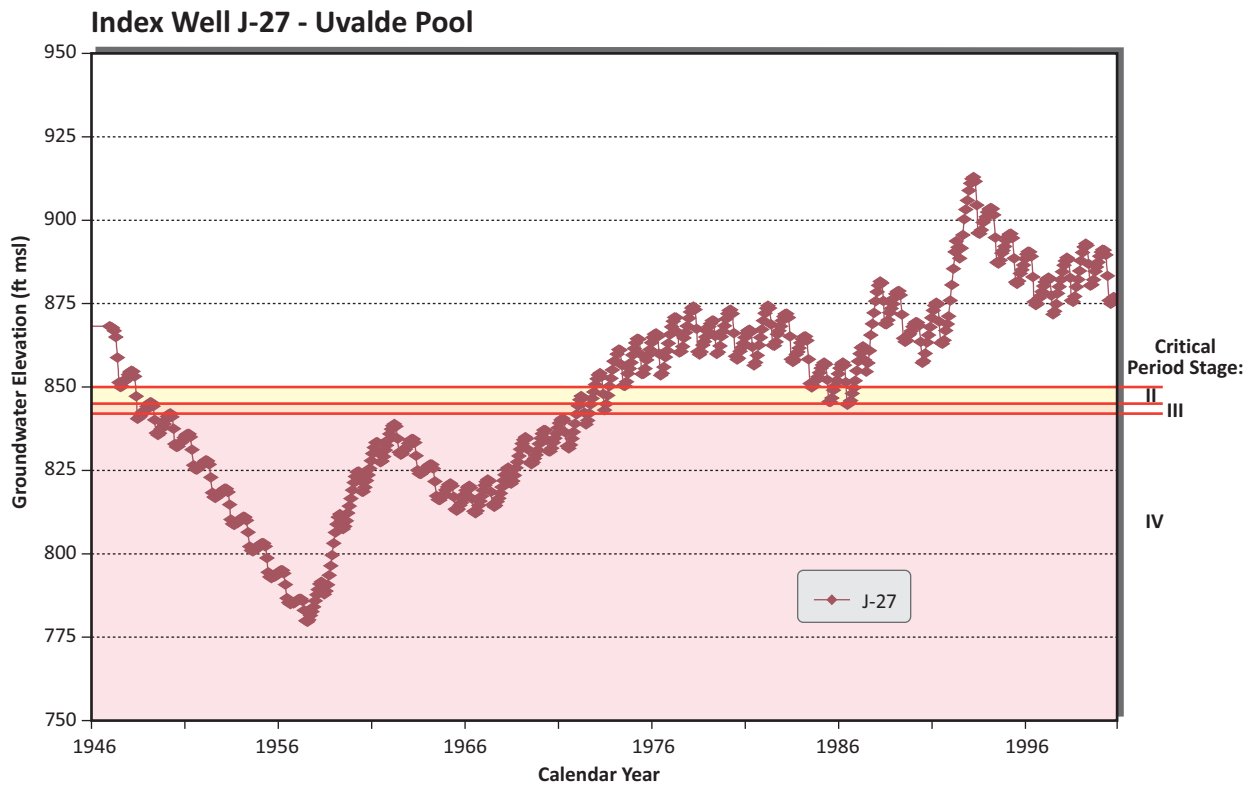
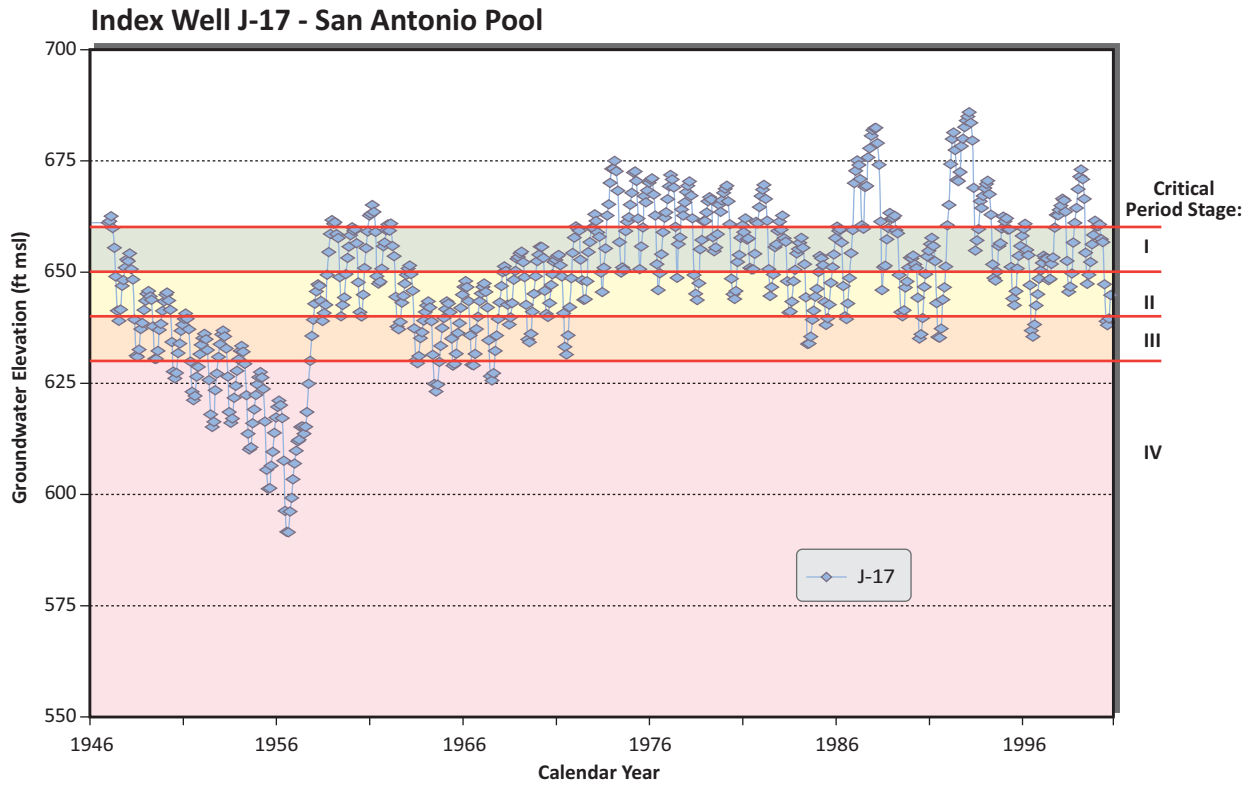

October 2008
 TODD ENGINEERS
 Alameda, California

Figure ES-3
Baseline Scenario
Water Levels in
J-17 and J-27

As shown on the figures, both pools are in some stage of critical period for most of the baseline scenario. For the San Antonio Pool, Stage IV reductions are in effect for most of the drought of record from about 1951 through 1956. Comal Springs is the primary trigger for most of the CPM stages. Critical flows at San Marcos Springs are typically reached after the CPM thresholds have already been triggered at Comal Springs. For the Uvalde Pool, Stage IV is in effect through the drought and into the 1970s.

Springflow output from the model was also used to develop a new baseline scenario for the surface water model. The baseline scenario conditions and results were provided to EAA in August 2007 for approval prior to proceeding with this study.

PRELIMINARY GROUNDWATER MODEL RUNS (CHAPTER 4)

Baseline conditions were applied to a series of preliminary groundwater model runs to evaluate the aquifer response to enhanced recharge for different locations, volumes, and timing. Recharge sites shown on Figure ES-1 were evaluated. Simulations of both one-time (slug) recharge and continuous annual recharge (applied seasonally each year) were evaluated.

Results indicated that recharge at almost all of the Type 2 sites immediately increased pumping over baseline due to a lessening of critical period stages caused by rising water levels and spring discharge. Centrally-located Type 2 sites contributed more to pumping than sites on the eastern and western ends of the basin. There, enhanced recharge contributed more to springflow, especially during wet conditions. A large proportion of enhanced recharge at the Lower Blanco site was discharged at San Marcos Springs with no benefits to pumping and relatively small benefits to Comal Springs. Recharge at the Cibolo site also had benefits to San Marcos Springs. Recharge at the Indian Creek site contributed to Leona Springs during wet conditions, but showed contributions to pumping and aquifer storage during dry conditions. The fate of enhanced recharge was similar for a particular site whether recharge was applied as a one-time slug or continuously.

Analysis of aquifer retention time indicated that enhanced recharge at the central and western recharge sites remained in the aquifer longer than recharge at eastern sites. This analysis identified sites where long-term storage was best achievable. Analyses under baseline conditions indicated that 80 percent of the enhanced recharge water was still in the aquifer after about one year at most western and central sites. The analysis indicates that these times could be used to develop recovery factors for EAA recovery permits. Although groundwater modeling indicated that some amount of enhanced recharge persisted for years in the aquifer, analyses beyond a few years were judged as more uncertain.

Recharge sites were also evaluated for their specific efficiency at maintaining springflow at Comal Springs above critical levels of 40 cubic feet per second (cfs) and 150 cfs. Results are summarized in Table ES-2.

Table ES-2. Annual Enhanced Recharge (in AFY) to Maintain Comal Springs Flow for Dry and Average Conditions

Type 2 Recharge Site	Dry Conditions (1947-1956) (AFY)		Average Conditions (1976-1983) (AFY)	
	40 cfs	150 cfs	40 cfs	150 cfs
Indian Creek	575,000	1,850,000	-	150,000
Lower Frio	400,000	750,000	-	80,000
Lower Sabinal	150,000	325,000	-	33,000
Seco Creek	155,000	315,000	-	35,000
Lower Hondo	160,000	325,000	-	35,000
Lower Verde	165,000	350,000	-	40,000
San Geronimo	117,000	260,000	-	25,000
Cibolo	160,000	340,000	-	27,000
Lower Blanco	5,000,000	> 10,000,000	-	300,000

Table ES-2 summarizes the enhanced recharge required to maintain Comal Springs at 40 cfs and 150 cfs during both dry and average hydrologic conditions. For dry conditions, maintaining springflow above 150 cfs takes about twice the amount for 40 cfs. In addition, an order of magnitude more water is needed for maintenance above 150 cfs during dry conditions than during average conditions. Under average conditions, Comal Springs flow is always above 40 cfs and does not require enhanced recharge for maintenance. As shown on the table, the San Geronimo site appears to be the most efficient at maintaining minimum springflow at Comal Springs, requiring about 117,000 AFY of enhanced recharge for springflow maintenance at 40 cfs and about twice that amount to keep springflow above 150 cfs during the drought of record. It is currently unknown whether the required amount of enhanced recharge could be achieved at the site and further study on site-specific infiltration rates is recommended. Although not indicated on the table, the Cibolo site is the most efficient for supplying both Comal Springs and San Marcos Springs.

Enhanced recharge at the western sites (Indian Creek and Lower Frio) is not efficient for springflow maintenance and requires much larger quantities of enhanced recharge than other sites. The Lower Blanco is the most inefficient for Comal Springs flow maintenance, given its downgradient location. Quantities of enhanced recharge required for these target levels could not likely be recharged there due to physical limitations. Further, Lower Blanco does not appear to be capable of maintaining springflow above 150 cfs during dry conditions.

SOURCE WATER AVAILABILITY (CHAPTER 5)

Potential sources of water evaluated for enhanced recharge include the following:

- Un-captured surface water across the recharge zone at the Type 2 sites
- Surface water at potential diversion sites along the Guadalupe River
- Unused EAA withdrawal permits
- Unrecovered groundwater and surface water that results from enhanced recharge (recirculation)

The potentially available surface water at the Type 2 sites and along the Guadalupe River was determined using Water Availability Models (WAM) developed by the TCEQ. The WAMs were modified to be consistent with baseline conditions by incorporating springflow output from the groundwater model into the WAM. Using regression analyses, the WAM time periods were extended to 2000 to coincide with the groundwater model.

The WAMs were used to generate unappropriated and marketable water at each of the designated R&R sites in the scope of services (Appendix A). For unappropriated water, a particular WAM simulation referred to as “Run 3” was conducted. This run accounts for all existing water rights in a particular basin with these rights exercised at their fully authorized diversion and storage amounts, typically without any return flows associated with the diversions. Following acquisition of proper water right permits from the TCEQ, these are the total quantities of streamflow that potentially could be available for recharge, less any diversion restrictions of streamflow use determined in the permitting process.

Results of this analysis are summarized in Chapter 5 and presented in Appendix B. One conclusion from the unappropriated analysis was that significantly less water was available for recharge at the western Type 2 recharge sites (Nueces Basin) than had been used in previous evaluations by HDR for the Region L Water Plan. For the model period (1947-2000), unappropriated water is only available during 17 years and 8 years at the Lower Sabinal and Lower Frio Type 2 recharge sites, respectively, and amounts are generally very small. This appears to be primarily the result of fully honoring the storage rights in the Choke Canyon Reservoir/Lake Corpus Christi system in the WAM analysis. Previous studies had assumed that impacts on the water supply and estuarine inflows would be mitigated with alternative water sources and/or financial mechanisms.

For this analysis, *marketable* water is assumed to be that portion of streamflow that is appropriated by existing water rights, but not fully utilized under current conditions. For this project, the idea is that such rights might be acquired (purchased or leased) from one or more water right owners during a period of time when owners do not need the water. For the development of marketable amounts of water, a simulation of the WAM referred to as “Run 8” was used. This analysis accounts for all existing water rights, but only to the extent the right has been exercised during the last 10 years of the model run (late 1980s to late 1990s). In general, the difference between the amount of rights used (Run 8) and the

amount of rights appropriated (Run 3) was viewed as marketable water. Additional adjustments were made to the WAMs to allow comparison of the output of these runs. Details of the methodology and results are provided in Chapter 5. Complete results for Marketable and Unappropriated water are presented in Appendix B.

In addition to the surface water analysis associated with the WAM, two additional water sources were evaluated including unused withdrawal permits and excess springflow due to enhanced recharge. The unused withdrawal permits represent EAA permit holders that do not pump their full allocation of groundwater each year. These unused permits account for a significant amount of water, especially during wet years when groundwater pumping is generally less. These amounts could potentially be leased or purchased as a source of enhanced recharge when groundwater is not needed for beneficial use. At first, the concept of pumping groundwater already in storage back to the recharge zone may not seem beneficial. However, because of the geologic complexities within the aquifer system, the strategy allows for movement of water to certain recharge sites where specific goals of either long-term storage or springflow maintenance can be obtained.

EAA staff provided the amount of unused permits from 1999 to 2006 for the evaluation of potential recharge source water. Average amounts of permits by pool and permit type are shown on Table ES-3. Actual annual amounts are shown on the graph following the table.

Table ES-3: Average Amounts of Unused Pumping Permits by County and Water Use

Pool	County	Average Unused Permits 1999-2006		
		Irrigation (AFY)	Muni/Ind. (AFY)	TOTAL (AFY)
Uvalde Pool				
	Uvalde	66,631	1,241	67,872
San Antonio Pool				
	Medina	54,478	2,840	57,318
	Bexar	25,717	22,044	47,761
	Comal	951	6,993	7,944
	Hays	867	4,243	5,110
	Subtotal	82,013	36,120	118,133
TOTAL		148,644	37,361	186,005

Illustration ES-3: Unused Withdrawal Permits 1999 – 2006

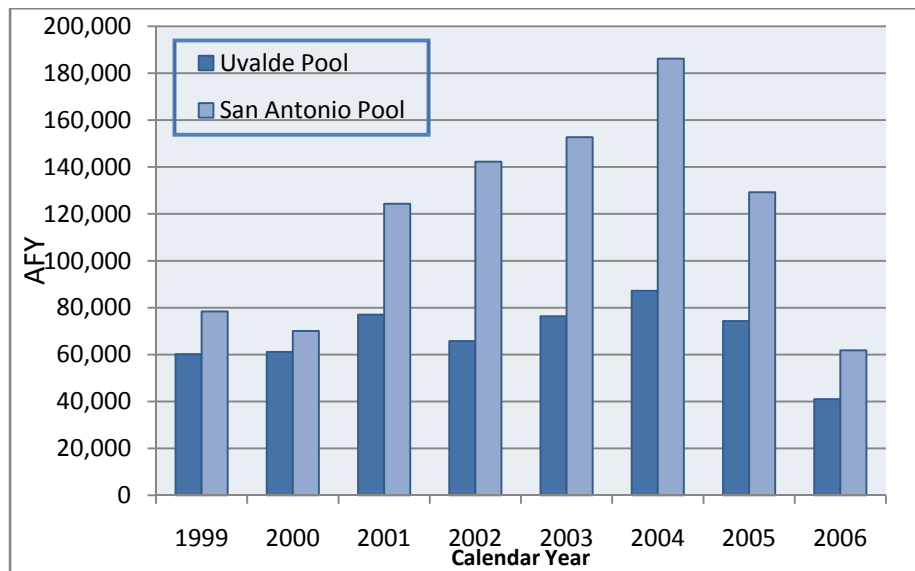

For irrigation permits, a portion of the allocation may not be available for offsite use as would be required by R&R strategies. According to EAA permit rules, one-half of an irrigation permit amount is tied to the parcel on which the irrigation permit is held (base permit) and generally cannot be pumped on other lands. To account for this base permit, unused irrigation permit amounts were adjusted downward by one-fourth, assuming that one-half of the permits represented the base portion of the permits. Applying this methodology, average annual amounts of unused permits of 51,215 AFY and 97,630 AFY were used for the Uvalde Pool and San Antonio Pool, respectively.

R&R COMPONENTS (CHAPTER 6)

To evaluate R&R strategies in a systematic manner, 29 components of recharge and recirculation were identified for analysis for both individual and combined analyses. This extra step allowed for the individual assessment of an R&R component's impact on critical period rules, water levels, springflow, and aquifer storage. For the purposes of this analysis, a component designates a specific location (such as one Type 2 site) linked to available source water (i.e., unappropriated or marketable streamflow, a new groundwater source, or recirculated water), either at that location or piped from a nearby source. Preliminary costs were also developed for the components as summarized in Appendix C. Components are described in detail in Chapter 6. Components are shown conceptually on Figure ES-4. Table ES-4 provides a list of the components (abbreviated to reflect the model simulation name), results from the analyses, and preliminary annualized costs.

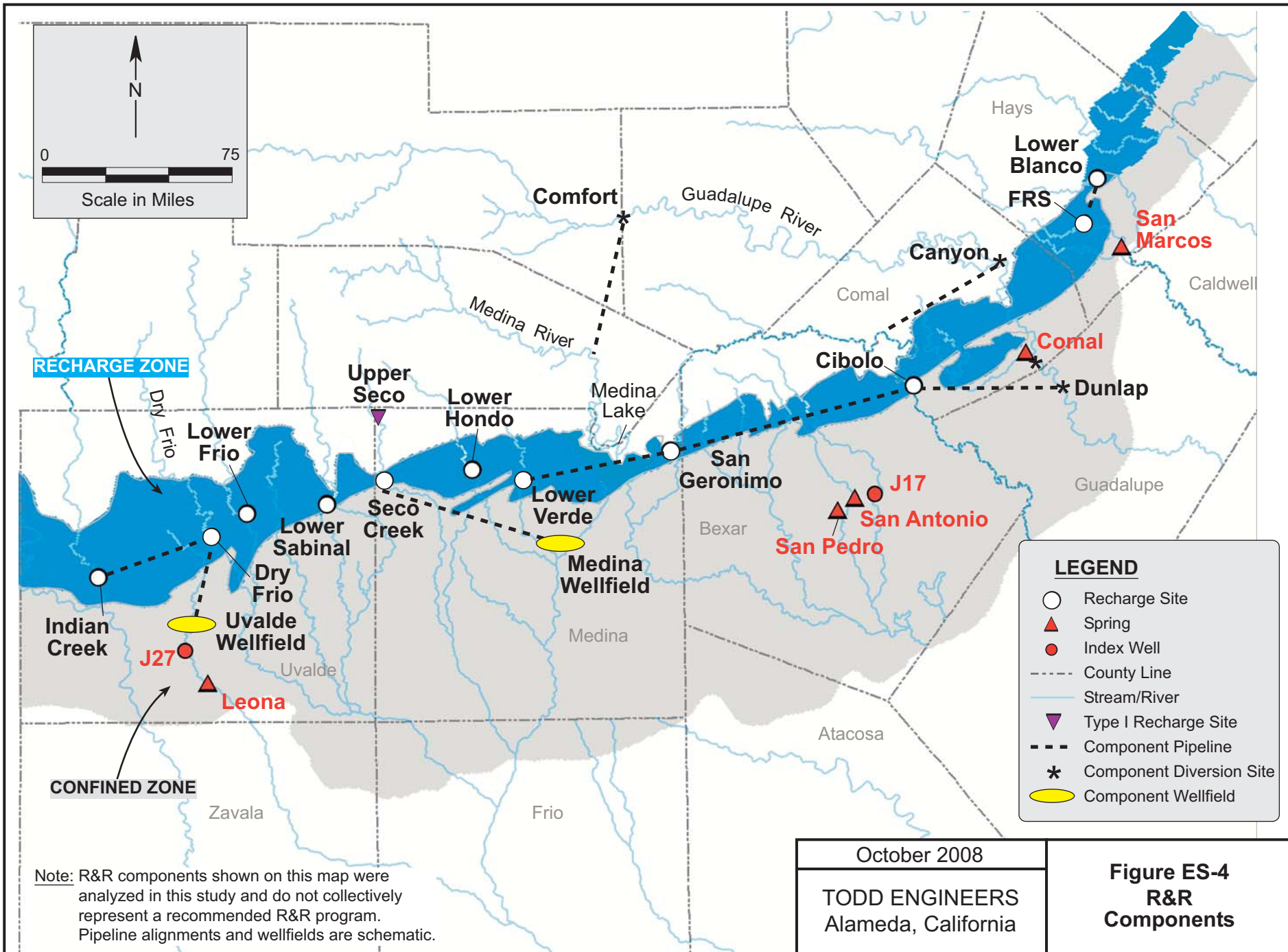

Table ES-4: R&R Components - Yield and Costs

Component		Recharge and Yield Average Conditions (1947-2000)				Recharge and Yield Drought Conditions (1947-1956)				Annual Costs	Annual Benefits - Average Conditions (Cost per AF)			
ID	Abbreviated Name for Model Simulation	Total Recharge (AFY)	Permit Pumping (AFY)	Comal Springs (AFY)	Remaining in Aquifer (AFY)	Drought Recharge (AFY)	Permit Pumping (AFY)	Comal Springs (AFY)	Remaining in Aquifer (AFY)	Annual Cost ¹ (\$)	Total Recharge (\$/AF)	Permit Pumping (\$/AF)	Comal Springs (\$/AF)	Pumping + Comal (\$/AF)
1	IC Type 2 Unappropriated ²	11,299	2,976	1,233	9,072	0	0	0	0	\$ 56,832,284	\$ 5,030	\$ 19,095	\$ 46,103	\$ 13,503
2	LF Type 2 Unappropriated	264	52	75	85	3	0	1	2	\$ 5,443,880	\$ 20,658	\$ 104,798	\$ 72,961	\$ 43,014
3	LS Type 2 Unappropriated	64	70	2	6	310	1	197	124	\$ 1,600,456	\$ 24,849	\$ 22,748	\$ 875,228	\$ 22,172
4	LH Type 2 Unappropriated	673	105	332	137	246	0	163	91	\$ 1,580,141	\$ 2,349	\$ 15,051	\$ 4,753	\$ 3,612
5	LV Type 2 Unappropriated	300	94	127	84	235	1	137	129	\$ 1,692,932	\$ 5,651	\$ 17,915	\$ 13,295	\$ 7,632
6	SG Type 2 Unappropriated	4,591	2,067	1,661	668	181	222	293	309	\$ 979,708	\$ 213	\$ 474	\$ 590	\$ 263
7	C Type 2 Unappropriated	24,020	3,587	10,292	4,137	3,767	769	2,165	1,581	\$ 4,107,688	\$ 171	\$ 1,145	\$ 399	\$ 296
8	LB Type 2 Unappropriated	80,829	442	2,514	2,297	10,965	378	293	5,502	\$ 9,018,341	\$ 112	\$ 20,412	\$ 3,588	\$ 3,051
9	IC Type 2 Maximum	24,083	8,897	4,776	24,529	2,147	55	108	1,755	\$ 56,832,284	\$ 2,360	\$ 6,388	\$ 11,899	\$ 4,156
10	LF Type 2 Maximum	9,820	2,987	1,995	4,934	4,421	1,491	714	2,373	\$ 5,443,880	\$ 554	\$ 1,823	\$ 2,728	\$ 1,093
11	LS Type 2 Maximum	3,224	1,882	1,618	1,254	683	81	409	228	\$ 1,600,456	\$ 496	\$ 851	\$ 989	\$ 457
12	LH Type 2 Maximum	2,997	1,677	1,784	1,246	480	4	348	204	\$ 1,580,141	\$ 527	\$ 942	\$ 886	\$ 457
13	LV Type 2 Maximum	1,120	594	691	644	330	0	233	196	\$ 1,692,932	\$ 1,512	\$ 2,850	\$ 2,450	\$ 1,317
14	SG Type 2 Maximum	4,807	4,260	3,436	1,423	322	223	413	355	\$ 979,708	\$ 204	\$ 230	\$ 285	\$ 127
15	C Type 2 Maximum	24,261	7,284	20,673	8,396	3,768	769	2,165	1,581	\$ 4,107,688	\$ 169	\$ 564	\$ 199	\$ 147
16	LB Type 2 Maximum	90,362	991	5,294	4,725	21,478	257	577	4,889	\$ 9,018,341	\$ 100	\$ 9,105	\$ 1,703	\$ 1,435
17	All L-18 WAM Unappropriated	122,200	8,219	16,635	6,473	15,679	1,946	2,808	-3,143	\$ 81,255,432	\$ 665	\$ 9,887	\$ 4,885	\$ 3,269
18	All L-18 HDR Available Water	132,496	25,405	22,529	14,106	49,245	3,921	5,416	13,968	\$ 81,255,432	\$ 613	\$ 3,198	\$ 3,607	\$ 1,695
19	L-18 (w/o LB) WAM Unappropriated	41,261	7,968	13,243	5,555	4,735	1,813	2,405	-1,338	\$ 72,237,090	\$ 1,751	\$ 9,066	\$ 5,455	\$ 3,406
20	L-18 (w/o LB) HDR Available Water	82,635	25,818	20,116	14,266	32,990	6,446	5,824	18,564	\$ 72,237,090	\$ 874	\$ 2,798	\$ 3,591	\$ 1,573
21	Excess Springflow (to Cibolo)	138,070	10,223	22,017	8,139	18,663	2,094	3,929	-2,617	\$ 184,004,972	\$ 1,333	\$ 17,999	\$ 8,358	\$ 5,707
22	Comfort and Medina to Hondo and Verde	63,798	21,411	22,250	7,798	5,302	3,406	3,120	-1,570	\$ 66,408,276	\$ 1,041	\$ 3,102	\$ 2,985	\$ 1,521
23	Canyon to Cibolo	105,081	14,861	43,816	5,827	7,782	2,393	4,179	-2,608	\$ 81,529,142	\$ 776	\$ 5,486	\$ 1,861	\$ 1,389
24	Dunlap to Cibolo	108,252	15,165	43,489	6,249	8,302	2,393	4,453	-2,549	\$ 106,857,228	\$ 987	\$ 7,046	\$ 2,457	\$ 1,822
25	Uvalde Unused Rights	42,419	13,725	9,541	9,500	37,514	3,339	6,287	26,455	\$ 22,699,730	\$ 535	\$ 1,654	\$ 2,379	\$ 976
26	Medina Unused Rights	75,021	28,459	24,861	5,837	61,887	9,758	28,515	23,615	\$ 52,394,806	\$ 698	\$ 1,841	\$ 2,107	\$ 983
27	Type 1	72,792	27,841	24,066	5,606	66,892	11,188	22,096	25,291	\$ 54,122,492	\$ 744	\$ 1,944	\$ 2,249	\$ 1,043
28	Comfort and Medina to San Geronimo	49,300	18,352	19,368	3,206	5,049	3,383	2,205	-1,509	\$ 64,114,911	\$ 1,301	\$ 3,494	\$ 3,310	\$ 1,700
29	Dunlap to San Geronimo	79,840	22,269	32,869	6,093	4,227	3,171	2,526	-1,665	\$ 312,703,268	\$ 3,917	\$ 14,042	\$ 9,514	\$ 5,671

¹Costs match the components included in each model simulation; see text for component description.

²Indian Creek cost contains a large pipeline to maximize recharge (Element P-10b in Appendix C). A smaller, less expensive pipeline (Element P-10a in Appendix C) was used for scenarios in Chapter 7.

The total amount of enhanced recharge that could be available for each component is shown in the “Recharge and Yield” portion of the table, along with the yield for both permit pumping and Comal Springs. The yield to pumping is the result of lesser CPM restrictions due to higher water levels and springflow. Additional pumping could be sustained above the amounts shown in the table. Annual averages are provided for the long term average (1947-2000) and the drought of record (1947-1956).

As shown on Table ES-4, yield for components 1 through 20 reflect the Type 2 recharge sites as stand-alone projects and as combined projects with various amounts of source water as previously described. Recharge and yield are much lower for the components using unappropriated water only, particularly during drought conditions. Regardless of the amount of water available for recharge, sites in the west result in most of the associated yield contributing to permit pumping, while recharge at eastern sites primarily results in increases to Comal Springs.

For the recharge site analysis of unappropriated water (Components 1 through 8), the most economical are the eastern sites with more recharge (Components 6, 7, and 8) Of those, the Lower Blanco site has relatively low yield compared to the amount of water potentially available at the site because almost all of the enhanced recharge is discharged at San Marcos Springs. In addition, it is unlikely that the large amounts of water available at the Lower Blanco sites could be effectively recharged due to physical site constraints. San Geronimo and Cibolo offer cost effective locations for maintaining critical flows at Comal Springs. Potential diversions of unappropriated water from the Guadalupe River from Canyon Lake or Lake Dunlap represent relatively large quantities of water, even though the components are associated with some of the highest costs. Unused withdrawal rights represent relatively large amounts of water for enhanced recharge, and if associated with long-term leases, could potentially provide the most water during dry conditions.

RECHARGE & RECIRCULATION SCENARIOS (CHAPTER 7)

Based on the simulations of the management components in Chapter 6, the most promising strategies were combined into regional R&R scenarios. These scenarios focus on increasing recharge to the aquifer for the benefit of water supply while increasing springflow above baseline conditions. There are hundreds of possible reasonable scenarios for combining various R&R strategies over time. Although our scope of work provided for only several scenarios, we developed seven scenarios to cover a broad range of combinations. Actual implementation of a regional R&R program will likely be contained within these bounds.

In these scenarios, EAA ARSR rules were applied to allow for the re-capture of enhanced recharge under certain conditions (referred to herein as enhanced pumping). Retention time of enhanced recharge in the aquifer was evaluated to develop recovery factors for enhanced recharge. Recovery factors for the various recharge sites are illustrated on Figure ES-5.

Recovery Factors

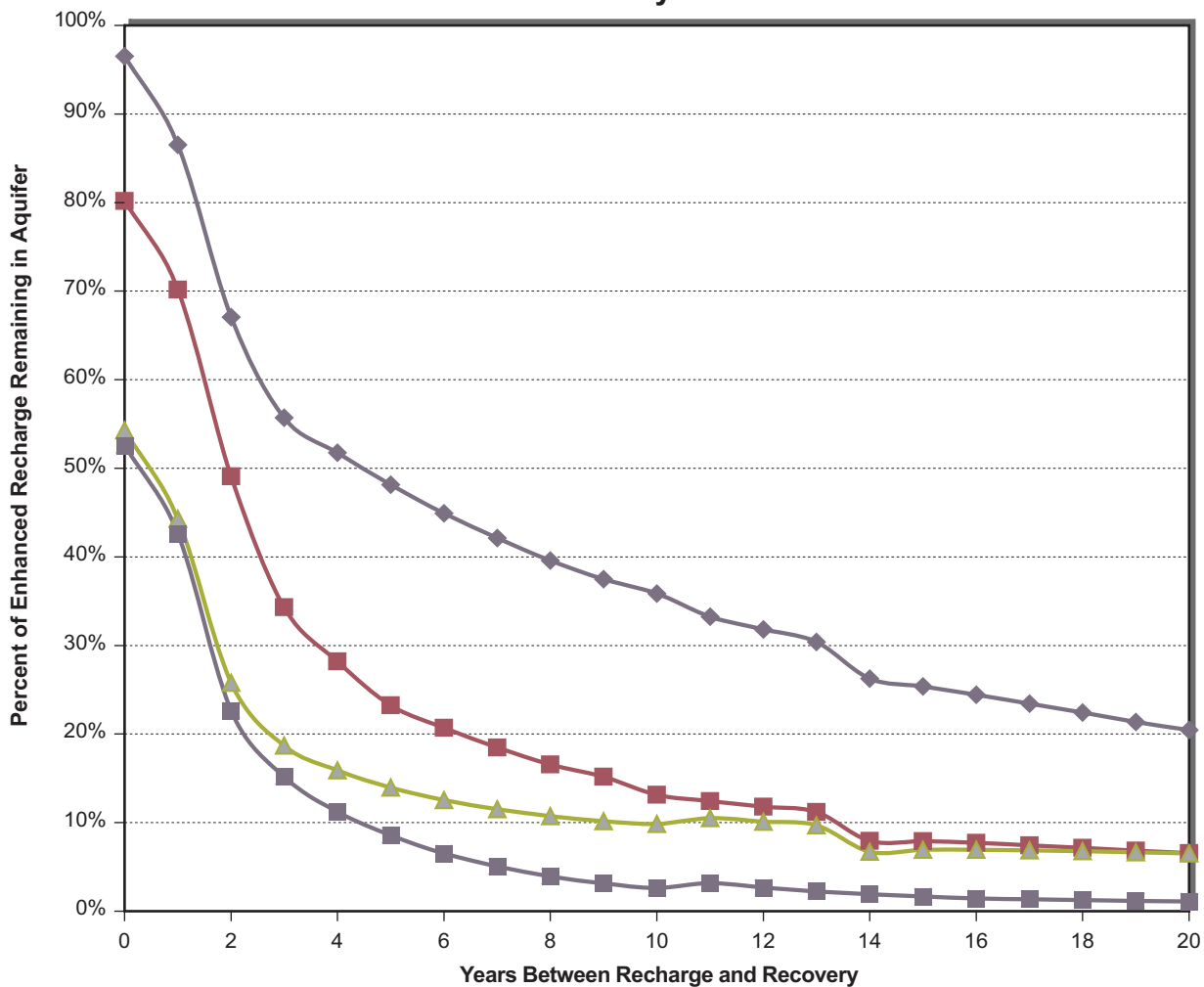

- ◆ Western Recharge Sites (Indian Creek, Dry Frio, Lower Frio)
- Central Recharge Sites (Lower Sabinal, Seco Creek, Lower Hondo, Lower Verde)
- ▲ San Geronimo Recharge Site
- Cibolo Recharge Site

Note: These factors relate the total amount of recharge to the portion that could potentially be recovered by pumping. Factors were developed by Todd Engineers based on aquifer retention times analyzed for each of the recharge sites under baseline conditions.

Enhanced recharge contributes initially to groundwater storage, but with time, storage decreases as spring discharge increases. Therefore, the net storage available for recovery decreases over time. This decrease over time is indicated by the recovery factor curves on Figure ES-5. Recovery factors are tabulated in Table ES-5.

Table ES-5: Recovery Factors – Percent of Recoverable Recharge at Recharge Sites

Time Since Recharge Occurred (Years)	Recovery Factors			
	Western Recharge Sites	Central Recharge Sites	Eastern Recharge Sites	
	Indian Creek, Dry Frio, Lower Frio	Lower Sabinal, Lower Hondo, Lower Verde, Seco Creek	San Geronimo	Cibolo
0	97%	80%	54%	53%
1	87%	70%	44%	43%
2	67%	49%	26%	23%
3	56%	34%	19%	15%
4	52%	28%	16%	11%
5	48%	23%	14%	9%
6	45%	21%	13%	7%
7	42%	18%	12%	5%
8	40%	17%	11%	4%
9	37%	15%	10%	3%
10	36%	13%	10%	3%
11	33%	12%	11%	3%
12	32%	12%	10%	3%
13	30%	11%	10%	2%
14	26%	8%	7%	2%
15	25%	8%	7%	2%
16	24%	8%	7%	1%
17	23%	7%	7%	1%
18	22%	7%	7%	1%
19	21%	7%	7%	1%
20	20%	7%	7%	1%

In developing the factors, the percent of enhanced recharge remaining in the aquifer was recorded for each elapsed year; percentages were developed for each half of the model and averaged. Factors are continued for 20 years simply to account for all of the water in the modeling analysis. Factors beyond a few years are less certain.

Scenario 1:

Most of the regional recharge components were combined for the scenarios to maximize the amount of enhanced recharge for the program (average of about 215,000 AFY for Scenario 1). Two simulations were conducted. The first scenario, Scenario 1a, was used to evaluate the fate of the enhanced recharge under baseline conditions. This analysis indicated that during dry conditions (1947-1973), about one-third of the recharge is captured through increased pumping (due to a reduction in CPM critical period stages). Less water is captured during average hydrologic conditions (1974-2000) because most of the permitted pumping is already being satisfied. A summary of the contribution of recharge to permit pumping, springflow, and aquifer storage is summarized in Table ES-6.

Table ES-6: Scenario 1a.

Model Section	Portion of Enhanced Recharge Contributing to: (% of total recharge)			
	Permit Pumping	Comal Springs	Other than Comal	Remaining in Aquifer
1947-1973	33%	29%	14%	24%
1974-2000	21%	38%	39%	16%
2001-2027	40%	34%	26%	27%

For Scenario 1b, enhanced pumping is added to the simulation allowing a portion of the enhanced recharge to be captured using the Recovery Factors described above when Comal Springs is above 40 cfs. This allowed about 70 percent of the enhanced recharge to be recovered, while maintaining the same amount of permit pumping and Comal Springs flow as under baseline conditions. Under this scenario, an average of about 150,000 AFY of enhanced pumping could be accomplished. These results, presented as a percentage of enhanced recharge, are summarized below on Table ES-7.

Table ES-7: Scenario 1b.

Model Section	Portion of Enhanced Recharge Contributing to: (% of total recharge)				
	Enhanced Pumping	Permit Pumping	Comal Springs	Springs Other than Comal	Remaining in Aquifer
1947-1973	70%	2%	3%	10%	15%
1974-2000	68%	2%	10%	20%	9%
2001-2027	72%	6%	5%	15%	17%

Summary graphs of the total yield and Comal Springs flow for Scenarios 1a and 1b are provided on Figures ES-6 and ES-7.

Total Yield of Scenario 1a (Without Enhanced Pumping)

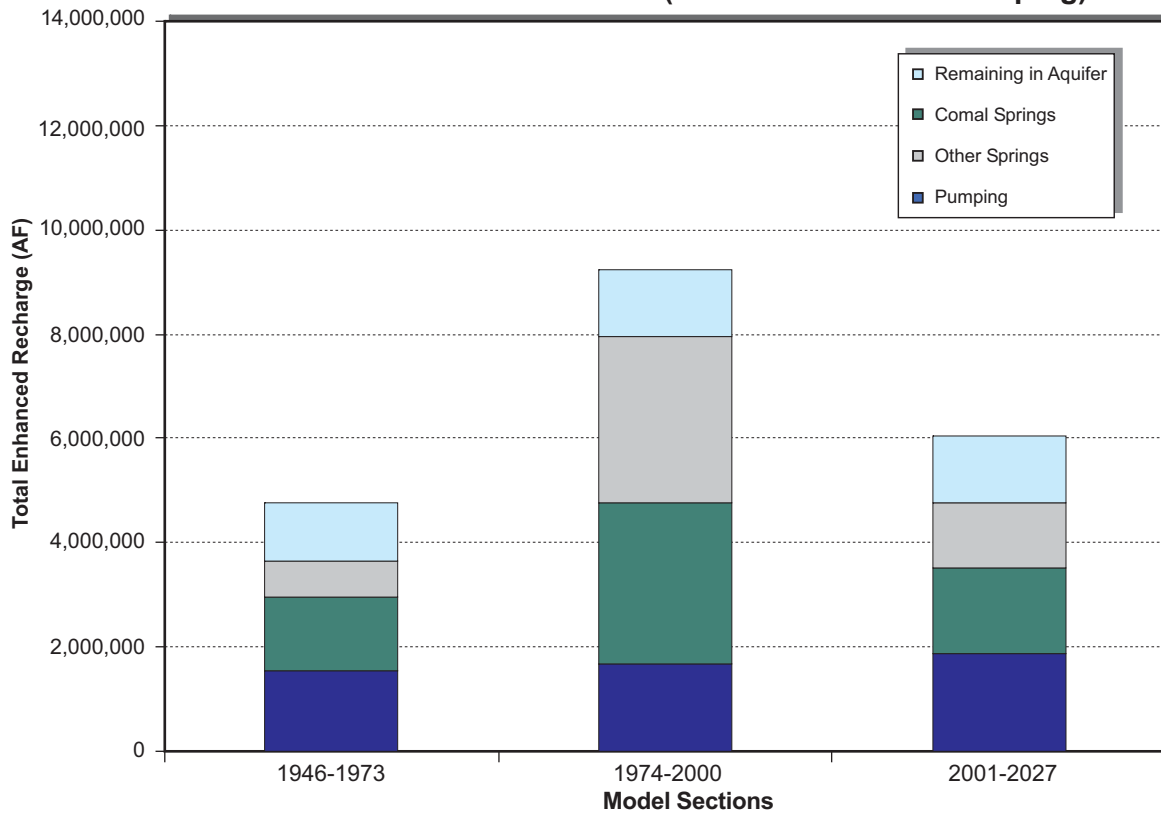

Comal Springs - Scenario 1a (Without Enhanced Pumping)

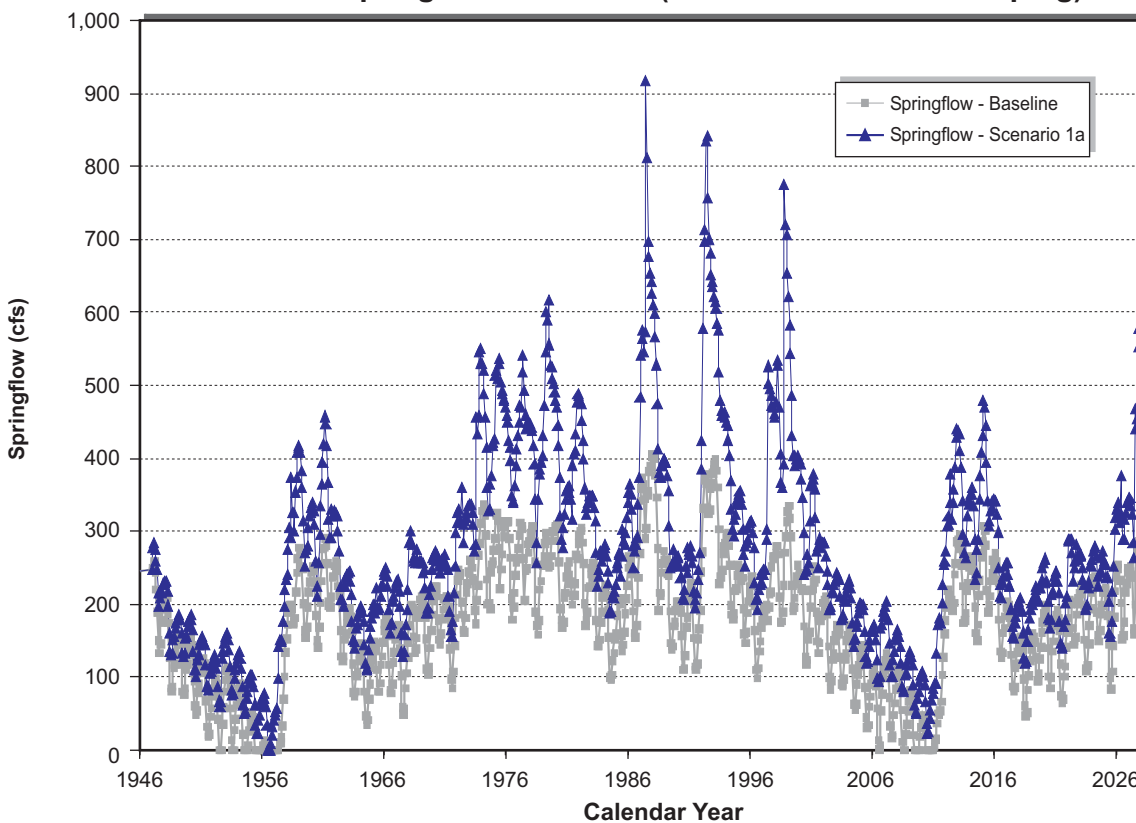

December 2008

TODD ENGINEERS
Alameda, California

Figure ES-6
Results of
Scenario 1a Without
Enhanced Pumping

Total Yield of Scenario 1b (With Enhanced Pumping)

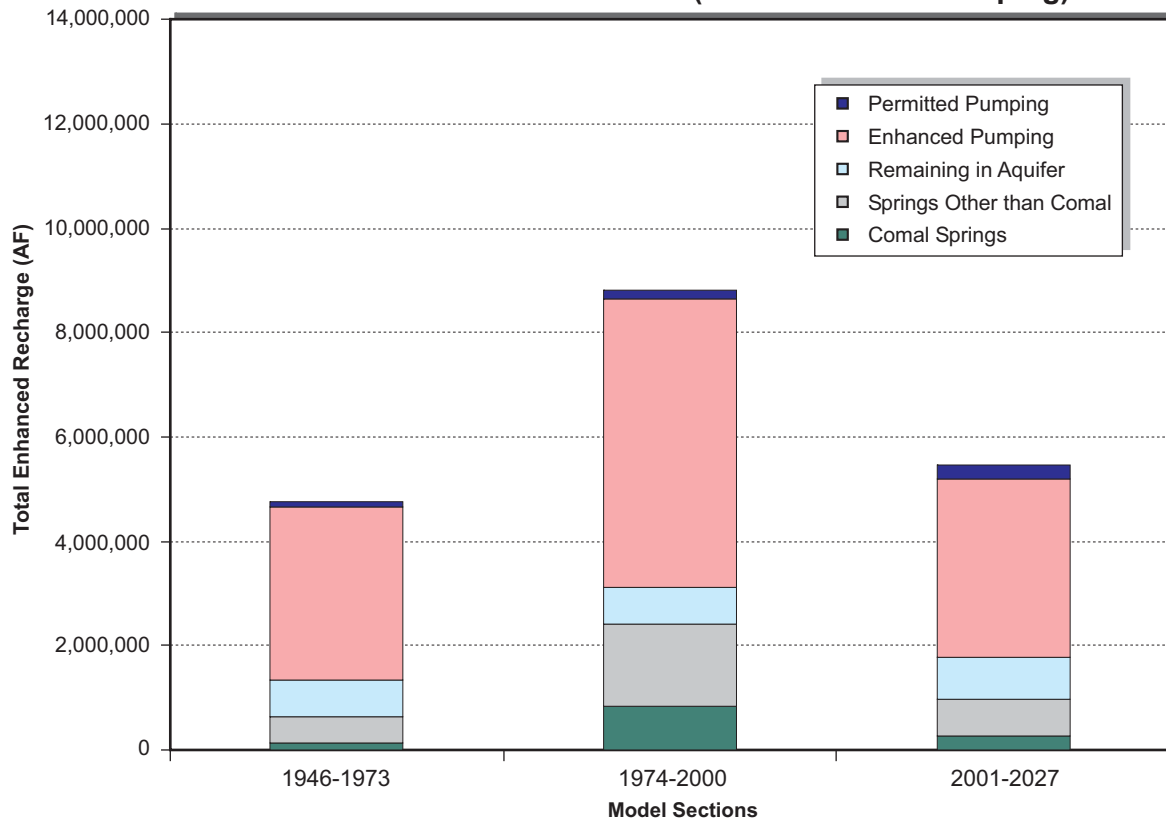

Comal Springs - Scenario 1b (With Enhanced Pumping)

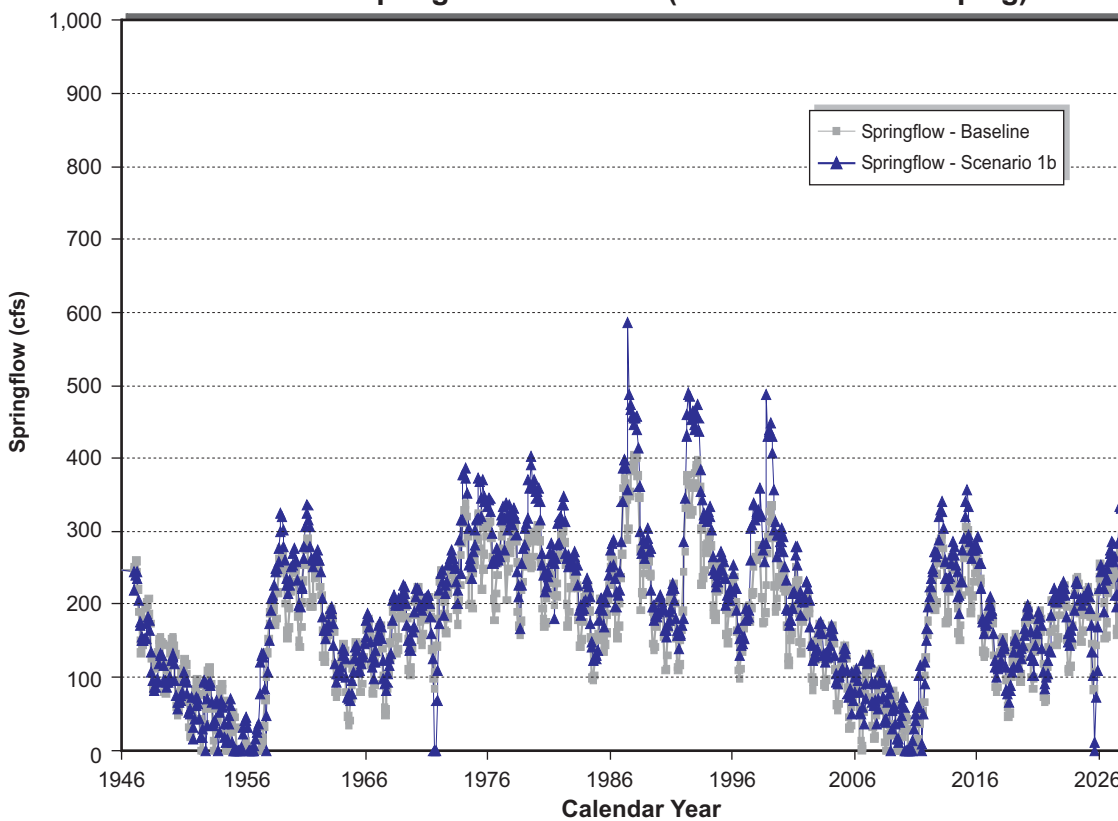

December 2008

TODD ENGINEERS
Alameda, California

Figure ES-7
Results of
Scenario 1b With
Enhanced Pumping

Scenario 2:

This scenario evaluates the amount of enhanced pumping that could be achieved when limited to times of Comal Springs flow between 40 cfs and 225 cfs. These limitations assume that additional water supply is not needed during wet conditions. Instead of 120,000 AFY to 200,000 AFY of enhanced pumping as seen in Scenario 1, the enhanced recharge is reduced to about 42,000 to 169,000 AFY on an average basis. Permit pumping was increased as a result of these enhanced pumping limitations.

Table ES-8: Results of Scenario 2

Model Section	Portion of Enhanced Recharge Contributing to: (AFY)				
	Enhanced Pumping	Permit Pumping	Comal Springs	Springs Other than Comal	Remaining in Aquifer
1947-1973	42,374	41,662	38,910	21,573	31,701
1974-2000	169,391	25,305	41,318	65,290	31,217
2001-2027	53,534	46,998	40,376	33,416	33,180

Figure ES-8 summarizes the results of Scenario 2 on yield and springflow at Comal Springs.

Scenario 3:

A recirculation pumping component is added for Scenario 3. Enhanced pumping is conducted when Comal Springs is above 40 cfs as in Scenarios 1, 2, and 3. But for wet time periods (Comal Springs flow above 225), it is assumed that all of the enhanced pumping may not be needed. To recover a portion of this water, about 10,000 AF/month is assumed to be conveyed back to the recharge zone for storage, subject to Comal Springs flow. Then, recirculation recharge is subsequently recovered under the recovery factors. This scenario results in the yield to water supply, springflow, and storage as summarized Table ES-9 below.

Table ES-9: Results of Scenario 3

Model Section	Portion of Enhanced Recharge Contributing to: (AFY)					
	Enhanced Pumping	Permit Pumping	Recirculation Pumping	Comal Springs	Other Springs	Remaining in Aquifer
1947-1973	116,741	4,013	17,015	9,033	15,831	30,173
1974-2000	186,836	13,156	66,119	35,205	62,437	33,729
2001-2027	120,328	13,687	19,707	13,399	27,785	34,460

Figure ES-9 summarizes the results of Scenario 3 on yield and springflow at Comal Springs.

Total Yield of Scenario 2

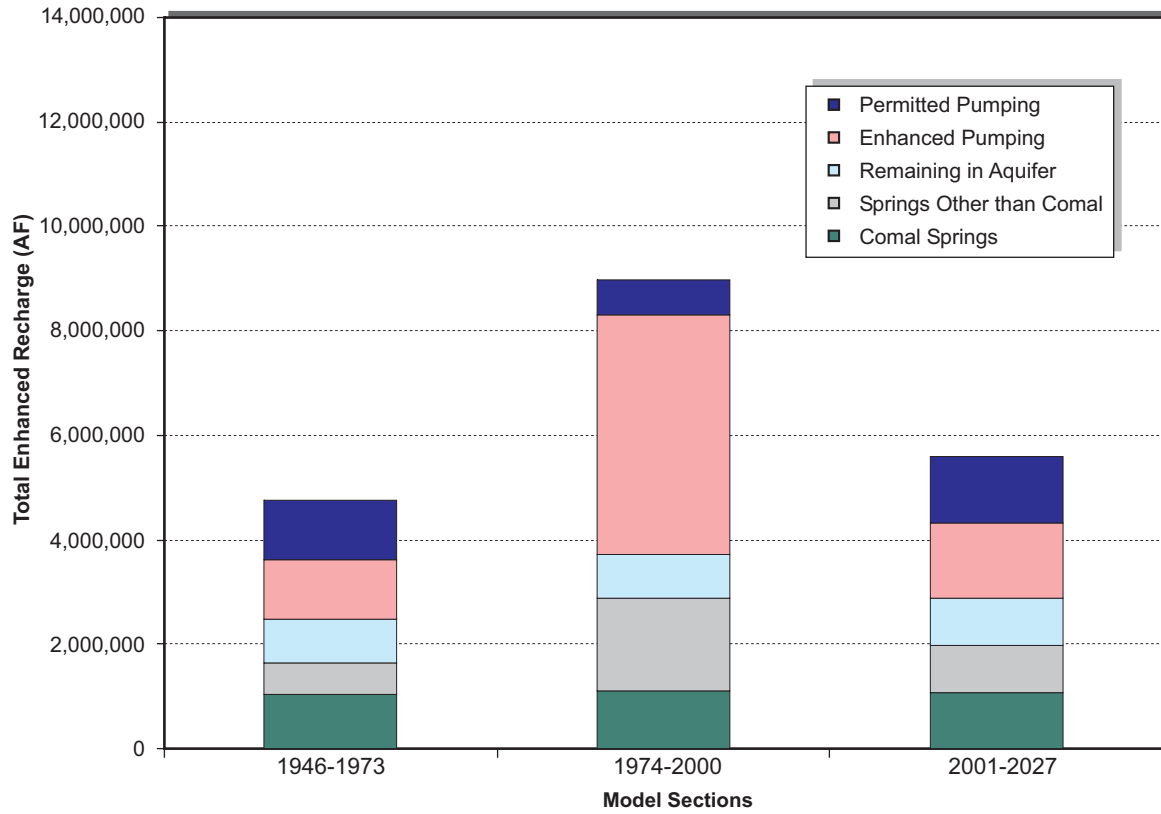

Comal Springs - Scenario 2

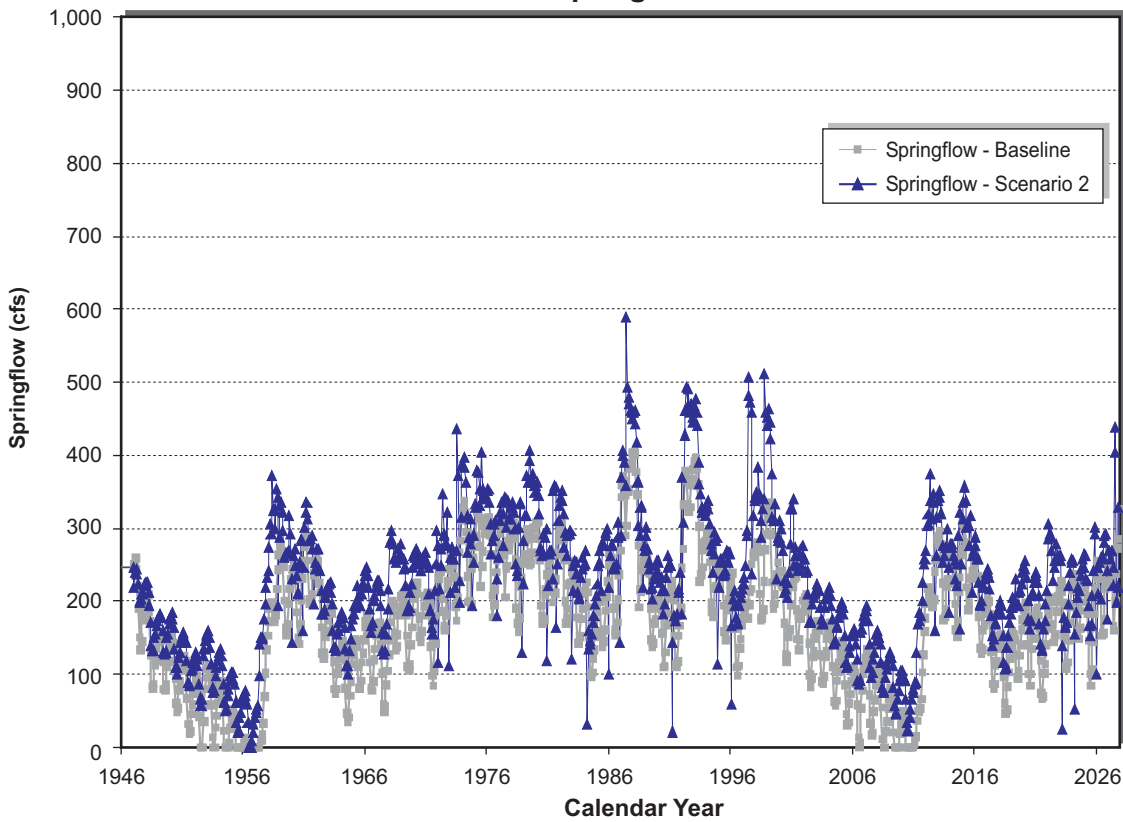

December 2008

TODD ENGINEERS
Alameda, California

Figure ES-8
Results of
Scenario 2

Total Yield of Scenario 3

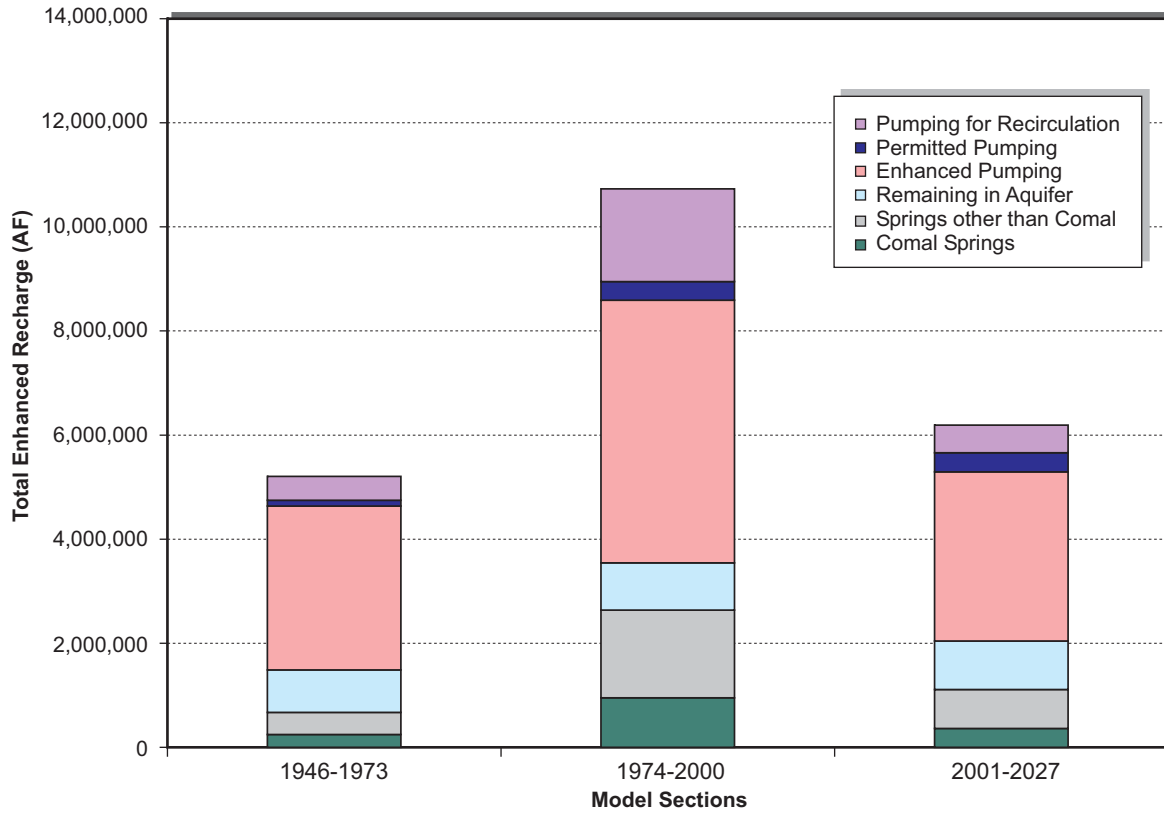

Comal Springs - Scenario 3

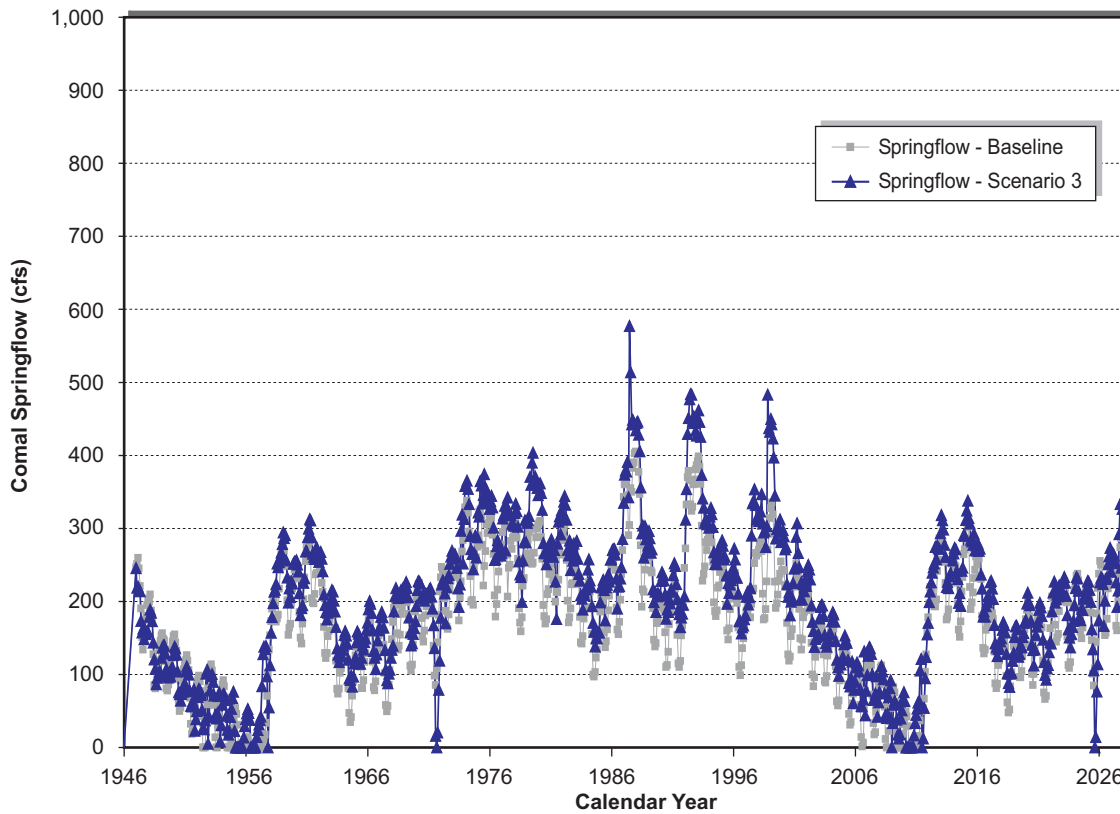

December 2008

TODD ENGINEERS
Alameda, California

Figure ES-9
Results of
Scenario 3 With
Enhanced/Recirculation
Pumping

Scenario 4:

This scenario is identical to Scenario 3 except that no enhanced pumping is conducted when flow at Comal Springs is above 225 cfs. Recirculation is the only pumping conducted during these relatively wet periods and was limited to 10,000 AF/month. The results showed much higher springflow during wet times when pumping was limited. Permit pumping also benefited with decreased enhanced pumping. Results are presented in Table ES-10 and Figure ES-10.

Table ES-10: Results of Scenario 4

Model Section	Portion of Enhanced Recharge Contributing to: (AFY)					
	Enhanced Pumping	Permit Pumping	Recirculation Pumping	Comal Springs	Other Springs	Remaining in Aquifer
1947-1973	99,153	11,619	17,015	11,340	18,915	34,767
1974-2000	84,361	40,461	66,119	76,909	92,607	41,619
2001-2027	90,717	28,790	19,697	23,520	32,863	41,330

Scenario 5:

This scenario was added to isolate the benefits of recirculation pumping in Scenario 4. For this scenario, all components of Scenario 4 were repeated except that recirculation pumping was suspended. The results indicate that most of the components of the water balance do not change significantly in the absence of recirculation pumping. Comal Springs registered some benefits, but they occurred mostly in wet times when recirculation recharge occurred. As shown from the results, recirculation pumping at these levels yields only small benefits if not recovered by enhanced pumping.

Table ES-11: Yield of Scenario 5

Model Section	Portion of Enhanced Recharge Contributing to: (AFY)					
	Enhanced Pumping	Permit Pumping	Recirculation Pumping	Comal Springs	Other Springs	Remaining in Aquifer
1947-1973	99,644	13,836	0	11,655	19,427	31,638
1974-2000	83,657	35,596	0	81,208	95,539	36,458
2001-2027	100,296	22,854	0	19,541	31,031	39,011

Results of Scenario 4 and 5 are shown graphically on Figures ES-10 and ES-11.

Total Yield of Scenario 4

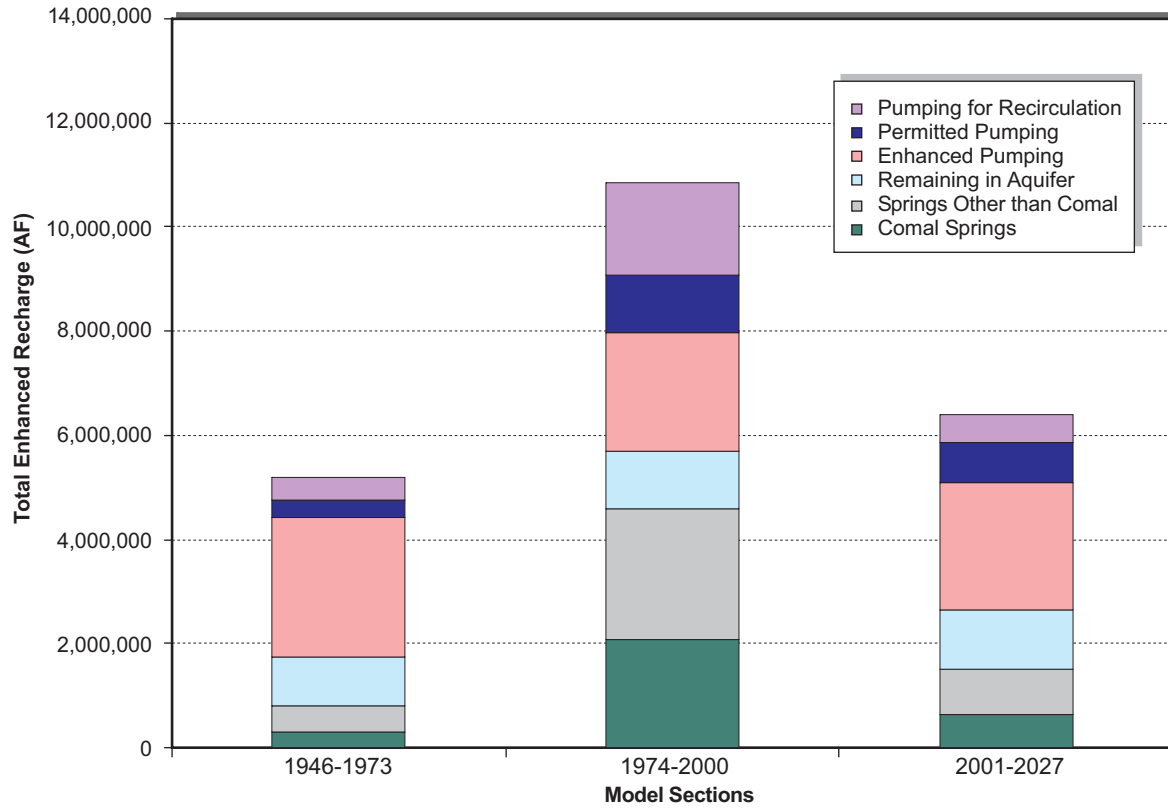

Comal Springs - Scenario 4

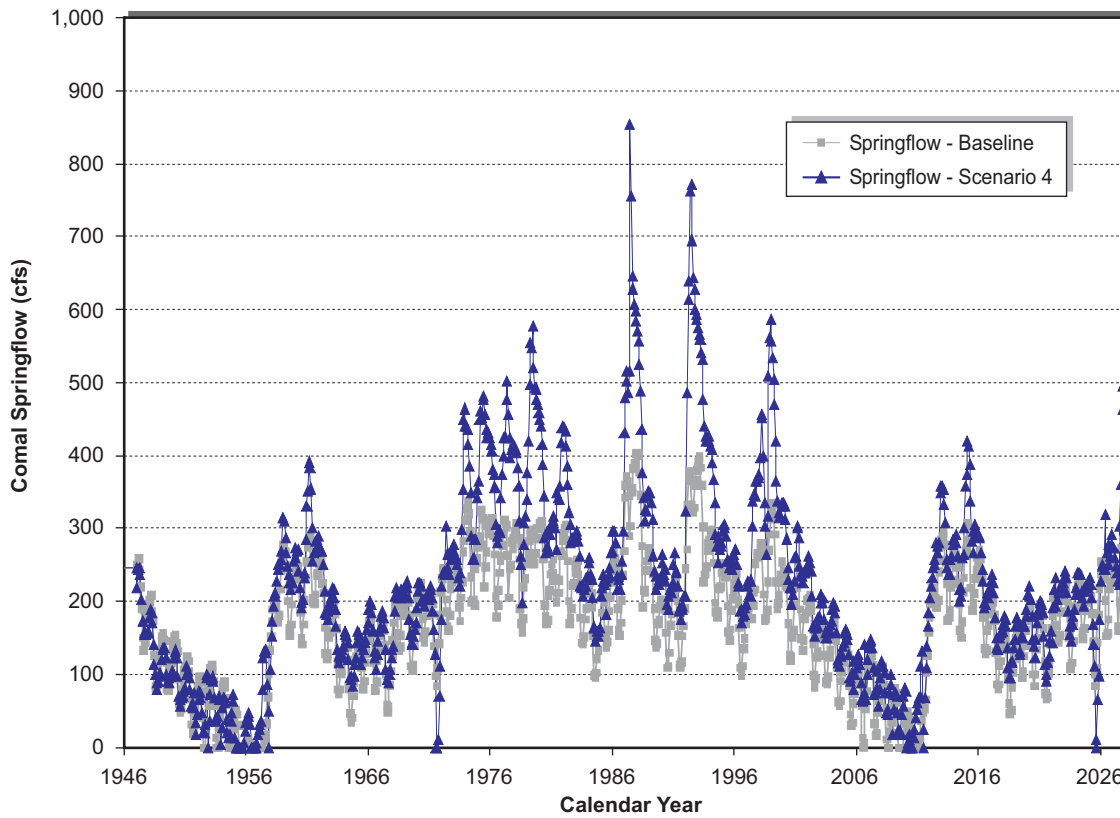

December 2008

TODD ENGINEERS
Alameda, California

Figure ES-10
Results of
Scenario 4

Total Yield of Scenario 5

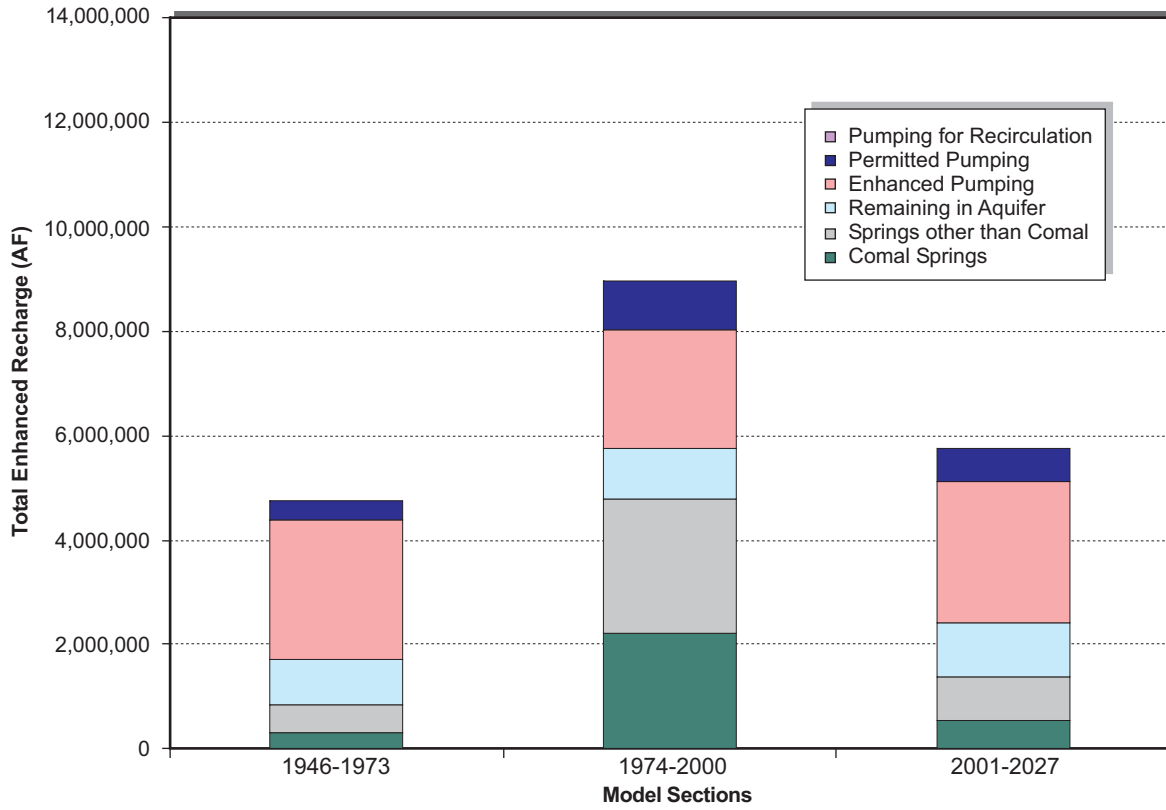

Comal Springs - Scenario 5

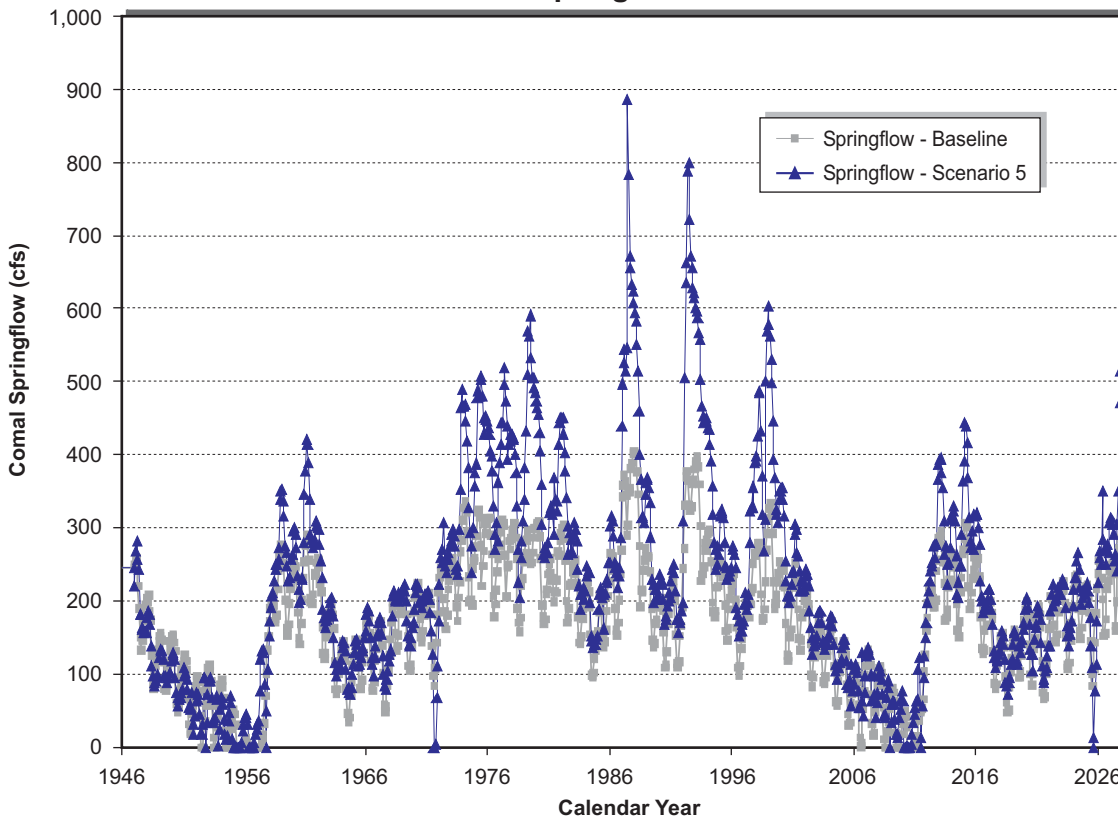

December 2008

TODD ENGINEERS
Alameda, California

Figure ES-11
Results of
Scenario 5

Scenario 6:

Scenarios 6 and 7 examine recirculation accomplished with excess springflow rather than water pumped from a recirculation wellfield. For this study, excess springflow is defined as the amount of increased flow at Comal Springs as a direct result of enhanced recharge. Although there is uncertainty as to how the excess springflow would be viewed by current regulations, this analysis was conducted in accordance with our scope of services to evaluate the conveyance of this water to the recharge zone. Excess springflow would be delivered to the Lower Verde recharge site. The amount of excess springflow depends on the amount of enhanced pumping in the model. For this scenario, no enhanced pumping was assumed during wet periods (Comal Springs above 225 cfs), leaving an average of about 46,000 AFY for recirculation. The actual amount available in each month of the model period was calculated with pre-scenario model runs. Results of the scenario are shown below in Table ES-12 and graphically on Figure ES-12.

Table ES-12: Results of Scenario 6

Model Section	Portion of Enhanced Recharge Contributing to: (AFY)					
	Enhanced Pumping	Permit Pumping	Recirculation Pumping	Comal Springs	Other Springs	Remaining in Aquifer
1947-1973	107,499	12,395	0	15,287	20,377	36,336
1974-2000	98,673	38,446	0	103,432	117,578	51,979
2001-2027	114,087	9,865	0	32,655	46,463	50,243

Scenario 7:

Scenario 7 builds on the analysis of excess springflow in Scenario 6 and adds the flexibility of transporting this water (along with unappropriated water at the Lake Dunlap diversion point) to either the Cibolo or Lower Verde recharge sites. Transport to the Cibolo site would occur when springflow at Comal Springs was below 225 cfs for springflow maintenance. Excess springflow was not recirculated if Comal Springs was below 40 cfs. Above 225 cfs, excess springflow was transported to Lower Verde for long term storage. Costs for this scenario were high because of the long pipelines from Lake Dunlap to the Verde recharge site. To reduce costs somewhat, recharge sites in the west that added little recharge water were eliminated. Further, the Lower Blanco recharge project was added back in to provide springflow protection at San Marcos Springs. This project could likely be optimized in the future to include a smaller and lower cost recharge structure.

This scenario results in the largest amount of enhanced pumping of the scenarios at about 168,000 AFY with only small impacts to permit pumping and Comal Springs flow, but at the highest cost. Results of Scenario 7 are summarized on Figure ES-13. All scenarios, including Scenario 7, are summarized on Table ES-13.

Total Yield of Scenario 6

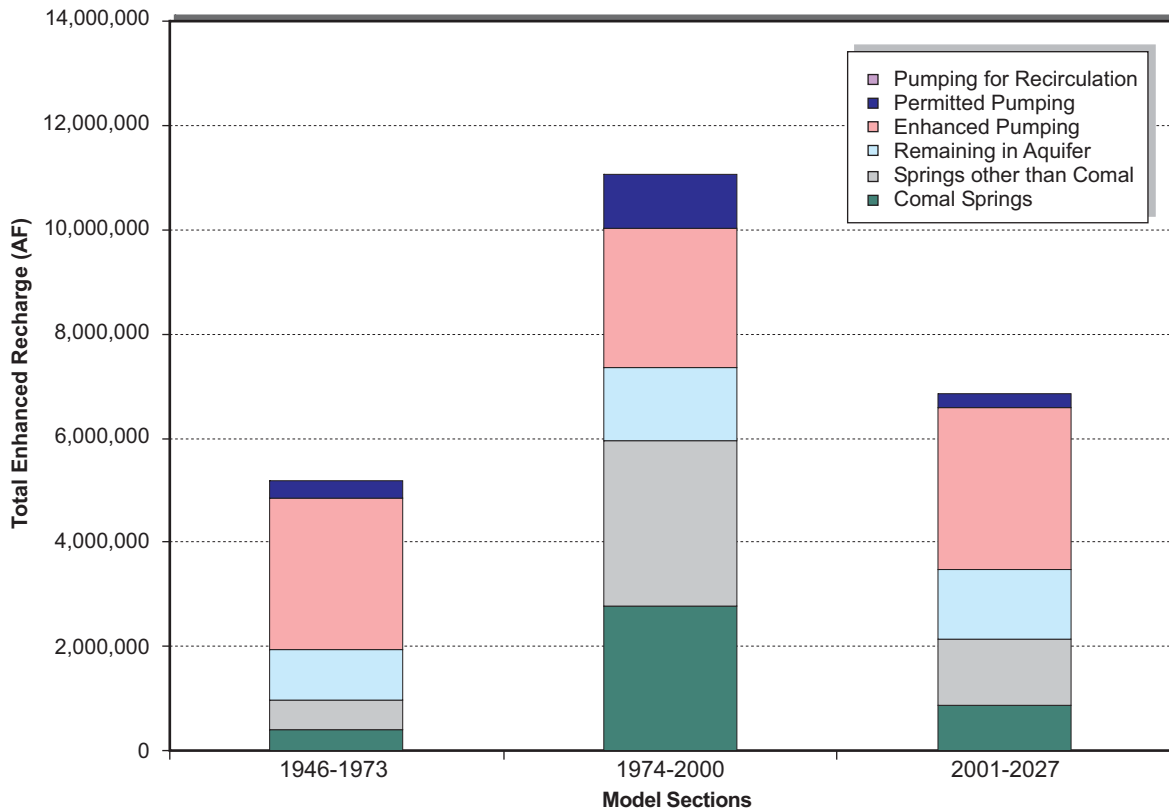

Comal Springs - Scenario 6

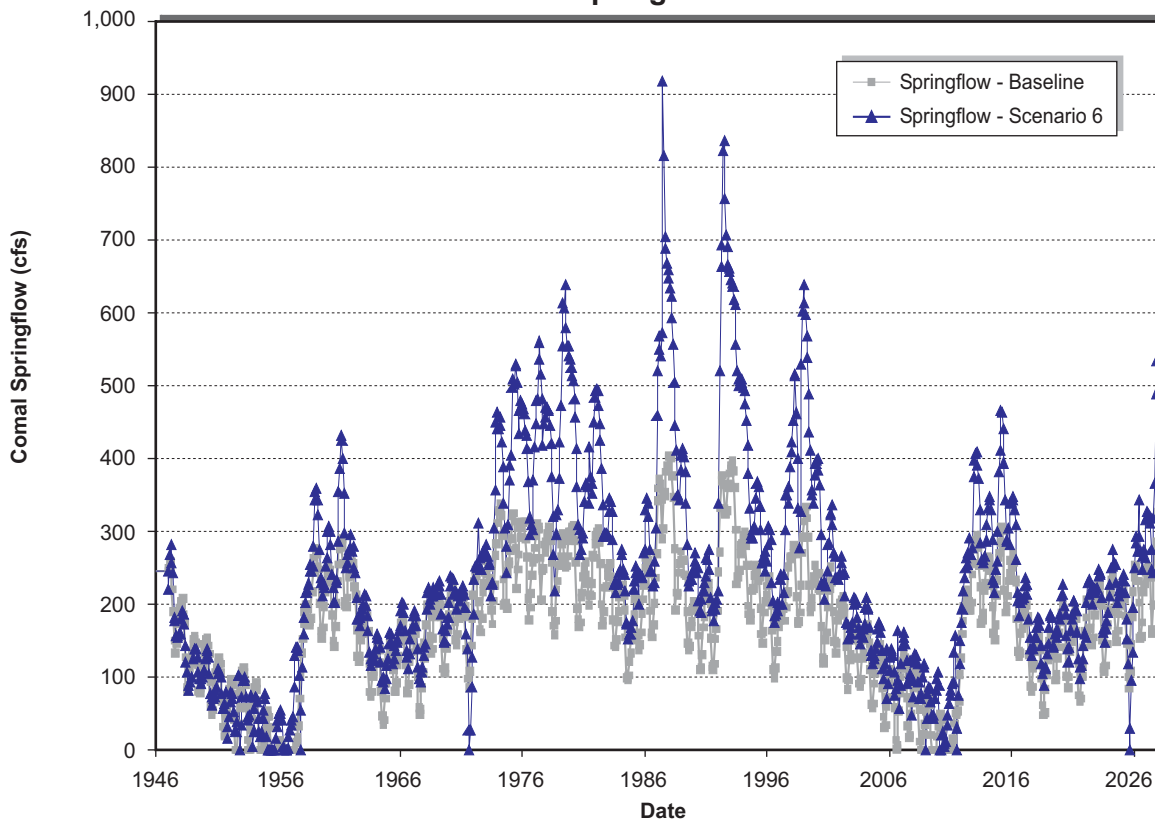

December 2008

TODD ENGINEERS
Alameda, California

Figure ES-12
Results of
Scenario 6

Total Yield of Scenario 7

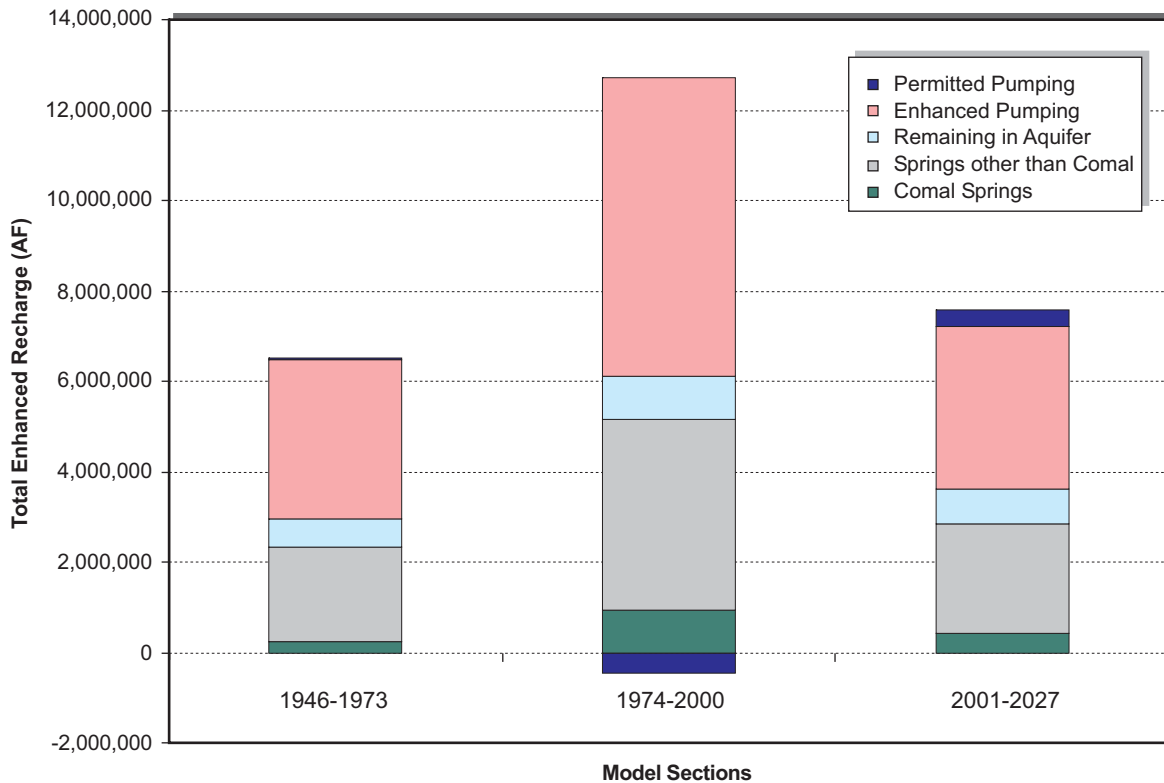

Comal Springs - Scenario 7

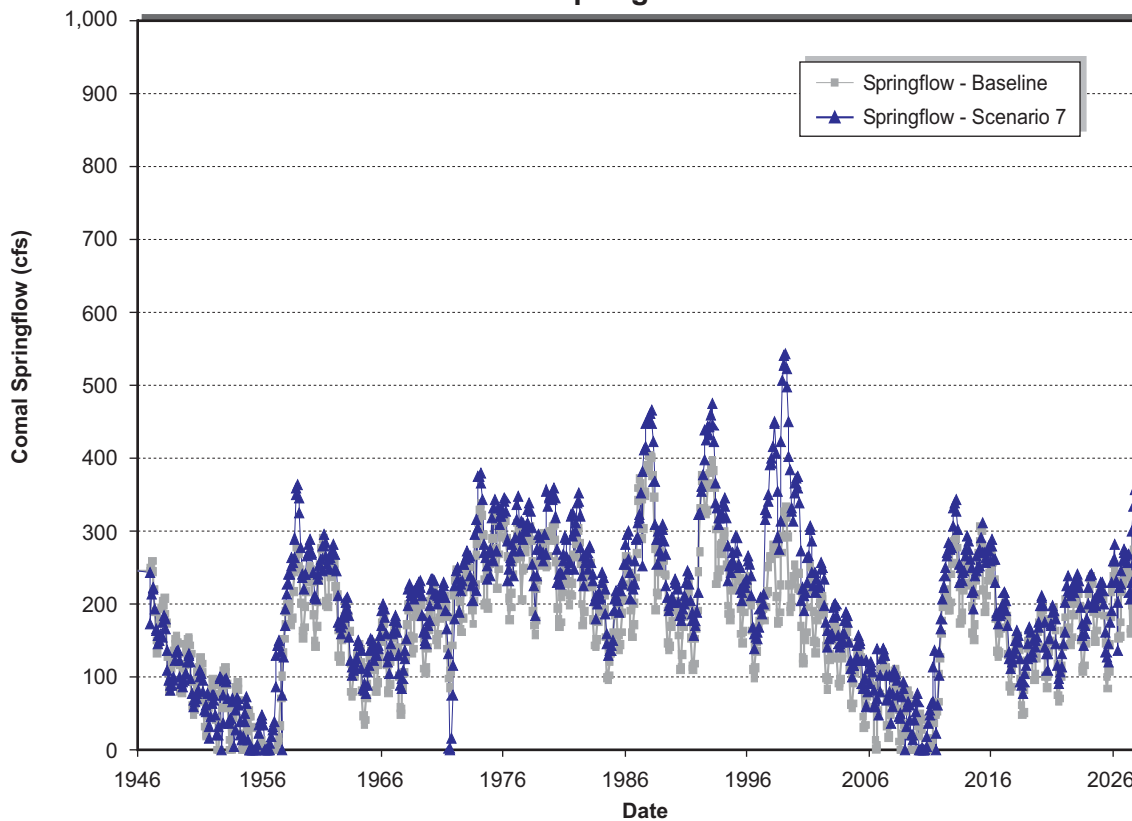

December 2008

TODD ENGINEERS
Alameda, California

Figure ES-13
Results
of Scenario 7

Table ES-13: Comparison of R&R Scenarios

Table ES-13a: Yield of Scenarios (AFY)

Abbreviated Name for Model Simulation	Recharge and Yield Average Conditions (1947-2027)					Recharge and Yield Drought Conditions (1947-1956)				
	Total Recharge (AFY)	Enhanced Pumping (AFY)	Permit Pumping (AFY)	Comal Springs (AFY)	Remaining in Aquifer (AFY)	Drought Recharge (AFY)	Drought Enhanced Pumping (AFY)	Drought Permit Pumping (AFY)	Drought Comal Springs (AFY)	Drought Remaining in Aquifer (AFY)
Scenario 1a (Without Enhanced Pumping)	215,123	0	62,519	74,377	15,909	112,962	0	18,994	32,366	49,810
Scenario 1b (With Enhanced Pumping)	215,093	149,741	6,533	15,143	9,831	112,935	76,822	-3,447	-3,814	33,989
Scenario 2	215,119	87,354	37,525	39,711	8,655	112,962	5,692	15,595	30,731	49,480
Scenario 3	248,846	139,579	10,160	18,978	11,487	116,940	75,927	-3,744	-620	34,755
Scenario 4	248,734	90,296	26,628	36,802	13,777	116,942	72,934	-2,258	-2,231	35,003
Scenario 5	215,110	93,380	23,802	37,011	12,995	112,931	72,934	-1,891	-2,115	34,410
Scenario 6	252,549	105,451	19,989	49,842	16,373	117,930	76,366	-12,313	652	42,814
Scenario 7	302,373	167,448	-551	20,057	10,911	127,763	79,765	-4,015	-3,469	34,866

Table ES-13b: Cost of Scenarios (\$M and \$/AF)

Abbreviated Name for Model Simulation	Costs (millions of dollars)		Annual Cost (dollars per AF) Average Conditions				Annual Cost (dollars per AF) Drought Conditions			
	Total Cost* (\$M)	Annualized Cost (\$M)	Total Recharge (\$/AF)	Total Pumping (\$/AF)	Comal Springs (\$/AF)	Pumping + Comal (\$/AF)	Drought Recharge (\$/AF)	Drought Pumping (\$/AF)	Drought Comal Springs (\$/AF)	Drought Pumping + Comal (\$/AF)
Scenario 1a (Without Enhanced Pumping)	\$1,775.9	\$278.0	\$1,292	\$4,446	\$3,737	\$2,030	\$2,461	\$14,634	\$8,588	\$ 5,412
Scenario 1b (With Enhanced Pumping)	\$1,775.9	\$278.0	\$1,292	\$1,779	\$18,355	\$1,622	\$2,461	\$3,618	NA	\$ 3,618
Scenario 2	\$1,775.9	\$278.0	\$1,292	\$2,226	\$7,000	\$1,689	\$2,461	\$13,058	\$9,045	\$ 5,344
Scenario 3	\$2,020.3	\$330.4	\$1,328	\$2,206	\$17,407	\$1,958	\$2,825	\$4,351	NA	\$ 4,351
Scenario 4	\$2,020.3	\$330.4	\$1,328	\$2,825	\$8,977	\$2,149	\$2,825	\$4,529	NA	\$ 4,529
Scenario 5	\$1,775.9	\$278.0	\$1,292	\$2,372	\$7,510	\$1,803	\$2,461	\$3,811	NA	\$ 3,811
Scenario 6	\$4,054.0	\$541.5	\$2,144	\$4,317	\$10,865	\$3,089	\$4,592	\$7,091	\$831,038	\$ 7,031
Scenario 7	\$3,863.2	\$521.9	\$1,726	\$3,127	\$26,021	\$2,792	\$4,085	\$6,543	NA	\$ 6,543

*Capital plus Other Project Costs (Appendix C)

DROUGHT YIELD

According to Regional Water Plan guidance, the TWDB recommends that water management strategies consider the quantity and reliability of water available under drought-of-record conditions. Because the drought-of-record had been defined in previous evaluations as the combined effects from 1947 through 1956, the results of the seven scenarios during this time period were provided previously (Table ES-13). Based on guidance provided by EAA and San Antonio Water System (SAWS), the results of the scenarios for the one worst year of the drought (1956 conditions) are also presented. These results are referred to in this report as “drought yield.” This drought yield is generally equivalent to the term “firm yield” as applied to the evaluation of a surface water supply.

Because the scenarios did not allow enhanced pumping below Comal Springs flow of 40 cfs, there is little or no drought yield for water supply pumping as defined above. However, scenarios could be devised for increasing drought yield. Analyses in this study indicate that pumping could be accomplished in certain areas of the aquifer without significant impacts to the springs. Drought yield would vary significantly based on the location of pumping.

OPTIMIZING CONSIDERATIONS

Numerous features could be incorporated into future R&R analyses to optimize the results. If only certain targets of water supply are needed, many of the more expensive components of enhanced recharge could be eliminated. The western recharge sites appear less economical due to the low availability of unappropriated water and could be dropped from the program. If marketable water could be acquired, the economics of the sites would improve.

CONCLUSIONS

Based on the analyses provided in this report, the following conclusions can be made.

- An R&R program can be developed that increases water supply while maintaining minimum required springflow.
- Considerations for optimizing the program should be based on specific management objectives developed by EAA and stakeholders such as when and under what conditions additional water supply is needed and what minimum flows are required for Comal Springs and during what time period.
- Using the water balance output from the model, benefits from enhanced recharge can be assessed for five main categories: enhanced pumping (for recharge recovery), permit pumping (due to lessening of CPM stages), Comal Springs, springflow at other springs, and aquifer storage (water remaining in aquifer).

- Baseline conditions developed for this study indicate that the aquifer is in critical period stages for most of the model time period. For the San Antonio Pool, critical period stages occur 65 percent of the time. Springflow at Comal Springs is significantly lower than the historical record and ceases to flow for 25 months during the drought of record (1947-1956).
- The EAA model, as modified, simulates newly-adopted CPM rules and pumping cap, and provides a valuable tool for evaluating R&R scenarios.

RECHARGE LOCATIONS AND YIELD

- Enhanced recharge produces immediate benefits to permit pumping. Benefits are less pronounced for average or wet conditions, but occur anytime the pools are in critical periods.
- Modeling indicates that increases to permit pumping occur before increases to spring flow.
- Enhanced recharge benefits springs other than Comal Springs, primarily during average and wet conditions.
- Enhanced recharge at the central recharge sites provides more combined benefits to permit pumping and Comal Springs flow than recharge at the eastern or western sites.
- The eastern and western recharge sites provide increased discharge to springs other than Comal Springs (specifically San Marcos and Leona springs).
- Groundwater modeling confirms the relationship between aquifer retention time and recharge location, i.e., eastern recharge sites are most effective for springflow maintenance and western recharge sites are most effective for long-term storage.
- Modeling indicates that at least 117,000 AFY of enhanced recharge during dry conditions is needed for maintaining Comal Springs flow at 40 cfs at the San Geronimo R&R site; more than twice that amount is needed for maintaining springflow at 150 cfs. Much more water is needed if recharge occurs west of the San Geronimo recharge site. Under average conditions, only about 25,000 AFY is needed at the San Geronimo site to maintain Comal Springs at 150 cfs.
- The Lower Blanco recharge site is ineffective for increasing water supply or maintaining springflow at Comal Springs. Recharge here contributes mainly to San Marcos Springs. However, significant quantities of water appear available for recharge and the costs for a Type 2 structure appear reasonable. Over time, continued enhanced recharge is expected to provide some benefits to Comal Springs.

SOURCE WATER

- Surface water modeling indicates that unappropriated water is available at each of the potential R&R sites analyzed for this study. Two diversion sites on the

Guadalupe River, Canyon Lake and Lake Dunlap, contain the largest amounts of unappropriated water on an average annual basis. In general, much more water is available at the eastern diversion/recharge sites.

- Surface water modeling with the Nueces WAM indicates significantly less unappropriated surface water available for recharge than previous studies, mainly because storage rights in the Choke Canyon Reservoir/Lake Corpus Christi are being fully honored in the WAM. Past studies have assumed that impacts on Corpus Christi water supply and estuarine inflows would be mitigated with alternative water sources and/or financially.
- Marketable water has been estimated at the diversion sites. Only small amounts of marketable water appear to exist at the Cibolo, San Geronimo, and Lower Verde recharge sites. Significant amounts of marketable water may exist at the Lower Sabinal, Lower Frio, and Indian Creek recharge sites. However, the availability of such water is uncertain and R&R scenarios did not include these totals.
- Unused Edwards Aquifer withdrawal permits represent a potentially large amount of water for recharge. Even after reductions are made to estimate the amount of base permit that could not be leased for off-site pumping, average unused permits from both pools appear to be available. For the Uvalde Pool, an average amount of about 51,215 AFY may be available. For the San Antonio Pool, an average amount of about 97,630 AFY is estimated. Recent information on long-term leases indicates that annual payments for leased water are made whether the water is needed or not. This indicates that water may be available in wet periods for recirculation. Modeling indicates advantages for pumping the water to certain recharge sites for long-term storage.
- The Guadalupe River diversion point at Lake Dunlap was considered optimal over the diversion points at Canyon or Comal River because Dunlap provided more unappropriated water and greater flexibility to capture excess springflow.
- Enhanced recharge produces increases in springflow that could be captured downstream and recirculated back to the aquifer as a potential source of long-term recharge. The amount of excess springflow is related to the amount of enhanced pumping that is conducted for recharge recovery. There may be regulatory uncertainty as to the availability of this water, but analyses were conducted as required by the Scope of Services for this project (Appendix A).
- Recirculation could also occur with a recirculation wellfield that could return unneeded water from Recharge Recovery permits back to the recharge zone. Wellfields were sized for capturing available unused Edwards Aquifer permits and would need to have a larger capacity if also used for recirculation.

R&R COMPONENTS

- A Type 1 structure on Seco Creek (or other centrally-located recharge site) would need a large capacity (100,000 AF or greater) to provide more significant

advantages than a direct infiltration structure. The analysis conducted for this study did not indicate sufficient benefits to justify the inclusion of a Type 1 structure. If determined to be beneficial for future management objectives, other Type 1 structures for the central R&R sites should be re-assessed (Lower Verde to Lower Frio).

- It was judged cost prohibitive to size pipelines to capture the maximum available water because of the infrequent occurrence and very large quantity. In addition, modeling indicates that the highest peak flows are not as beneficial over time because they occur at a time when water levels are already relatively high. Nonetheless, this study provides costs that optimize capture of a reasonable maximum quantity that optimizes yield rather than costs. Additional pipeline and reservoir sizing were beyond the scope of this project.

SCENARIO DEVELOPMENT

- Recovery factors, such as those developed for this study, can be used for implementation of ARSR rules for capture of enhanced recharge through enhanced pumping.
- Recovery factors generally allow for capture of a larger portion of enhanced recharge from western and central R&R sites.
- Much of the recharge water occurs during wet times and may be held longer in aquifer storage with recharge at the western sites.
- Most of the source water is available at eastern locations during wet conditions.
- Pipeline costs, mainly those needed for Guadalupe diversions, account for more than 50 percent of R&R scenario costs. Pipeline capacities may require additional optimization steps to reduce costs and meet management objectives.
- Without more specific objectives for an R&R program, no one scenario stands out as the most optimal. Several scenarios meet individual potential objectives. The optimal program would combine components of scenarios to meet specific objectives.
- Yields as presented in this study are long-term averages; short-term results may be more or less favorable than presented.
- Yields are indicative of regional benefits and may not be representative of local conditions.
- R&R programs may be further optimized for local projects and short-term results based on specified objectives.

1. INTRODUCTION

The San Antonio segment of the Balcones Fault Zone Edwards Aquifer (Edwards Aquifer) is one of the most productive aquifer systems in the nation and supports water supply and endangered ecosystems across a seven-county region. For more than three decades, the Edwards Aquifer Authority (EAA), its predecessor, and others have evaluated groundwater management strategies to more productively use the shared resource (TDWR, 1979; HDR et al., 1991; EUWD, 1992; HDR, et al., 1998; SCTRWPG, 2006). These strategies have involved, among others, enhancing natural recharge and recirculating groundwater discharge back into the aquifer system.

This study builds on previous investigations and re-evaluates recharge and recirculation (R&R) strategies incorporating:

- analysis with an improved computer flow model,
- updated estimates of available source water, and
- recently-adopted EAA rules for various aspects of aquifer management.

The study also evaluates combinations of strategies and provides preliminary costs for facilities to support implementation of an R&R program. This report is part of Phase IV of various R&R tasks performed by Todd Engineers for EAA. It summarizes previously-reported work on Phases I and II and describes new analyses conducted in Phase III. It is herein referred to as the Phase III/IV report.

1.1. BACKGROUND

The EAA and its predecessor, the Edwards Underground Water District (EUWD), have constructed four small-scale recharge structures to capture and hold excess streamflow crossing the recharge zone (EAA, 2007). Although these structures have been shown to be effective at enhancing natural recharge, the benefits of a regional recharge enhancement program have not yet been realized. A larger enhanced recharge program, designated as Water Supply Option L-18, is incorporated into a 2006 Regional Water Plan prepared by the South Central Texas Regional Water Planning Group (SCTRWPG, 2006). Construction of a phased L-18 program is scheduled to begin in 2010.

Enhanced recharge programs are expected to increase groundwater discharge at major springs fed by the Edwards Aquifer. Preliminary evaluations of recirculating some portion of the increased springflow back to the recharge zone indicated some benefits for aquifer management (HDR, et al., 1998). In addition, regional heterogeneities in the aquifer system may provide opportunities to increase long-term storage of recharge water in the aquifer. For example, recharge could occur in the western area of the aquifer where it is not as readily discharged to springs as recharge in the east.

Previous evaluations of aquifer response to various scenarios of recharge and/or recirculation were conducted with a mathematical groundwater flow model, GWSIM IV, based on an older model code (SCTRWPG, 2006). Given the limitations of this model as a management tool, EAA retained a team of modelers led by the U.S. Geological Survey (USGS), Edwards Aquifer investigators, and karst aquifer experts to construct an updated and more sophisticated groundwater flow model based on the widely-used MODFLOW code. This model, completed in 2004, provided the ability to more easily simulate aquifer response to changing management operations (Lindgren, et al., 2004).

Aquifer management was changed significantly in 2007 with amendments to the EAA Act by the Texas State Legislature (2007). As a result of the amendments, EAA adopted new management rules including a new cap on Permit pumping and a revised Critical Period Management (CPM) Plan (EAA, 2008). These new rules not only affect the management of the aquifer, but impact the amount of surface water available for recharge and recirculation. To incorporate appropriate amounts of recharge water into the Phase III analysis and to adhere to regional planning guidelines, available surface water was re-evaluated using the Surface Water Availability Model (WAM), developed and updated by the Texas Commission on Environmental Quality (TCEQ). The WAM was further updated and modified for this study, incorporating the newly-adopted EAA CPM rules.

This Phase III study builds on and expands the original work conducted by others on management strategies and the work conducted by Todd Engineers in Phases I and II. Contributions of this phase of work include the following:

- Application of the MODFLOW groundwater management model to R&R management strategies
- Evaluation of sources of water for R&R including local surface water, excess springflow, unused withdrawal rights in the Edwards Aquifer, and diverted surface water from the Guadalupe River
- Incorporation of the Senate Bill 3 (S.B. 3) amendments, which resulted in revised CPM rules for aquifer management as adopted by EAA
- Updated costs for management strategies
- Scenarios for evaluating R&R programs for possible incorporation into the regional planning process.

1.2. PURPOSE AND GOALS

The purpose of this project is to assess R&R management strategies and combine them into scenarios that benefit aquifer uses including municipal, irrigation, industrial, and environmental. Benefits to the region are evaluated in terms of increased water supply and maintaining minimum springflow at key springs including Comal and San Marcos springs.

1.2.1. SPRINGFLOW MAINTENANCE

Springflow in the eastern discharge area of the Edwards Aquifer provides numerous regional benefits including support of aquatic ecosystems and protection of endangered species; water for downstream uses, bays, and estuaries; and recreational and economic benefits. Protection of these natural resources and maintenance of minimum springflows at the two primary springs, Comal and San Marcos springs, are key objectives for any aquifer management strategy.

The U.S. Fish & Wildlife Service (USFWS) has analyzed various springflow requirements for the protection of aquatic ecosystems and endangered species. The USFWS recovery plan, revised in 1996, provides minimum springflows required for the prevention of take, jeopardy, or adverse modification of critical habitat (USFWS, 1996). The take and jeopardy flows listed for Comal Springs for protection of the Fountain darter are 200 cubic feet per second (cfs) and 150 cfs, respectively. For various species at San Marcos Springs, both take and jeopardy are listed at 100 cfs. USFWS also notes that it may be possible for flows to fall below these levels for short periods of time, but not for extended periods (USFW, 1996). Additional studies are ongoing, and minimum springflows are subject to revision in the future.

EAA CPM rules were developed to maintain springflow by reducing pumping during critical times. Comal Springs flow of 225 cfs, 200 cfs, 150 cfs, and 100 cfs trigger various levels of withdrawal reductions. Similarly, springflow of 96 cfs and 80 cfs are reference triggers for San Marcos Springs. These triggers are incorporated into the Phase III analysis. In addition, the scope of work provided by EAA for this project also requires additional analysis for maintaining springflows at 150 cfs and 40 cfs. The provision of 40 cfs as a minimum discharge is used as one of several reference points in the evaluation of various management strategies and does not indicate regulatory acceptance or legal requirements.

1.2.2. SUSTAINABLE YIELD

An additional goal for R&R strategies is to examine the potential for increasing the sustainable yield from the aquifer while protecting springflow. Given the potential reductions associated with CPM rules, Permit pumping from the aquifer may be cut up to 40 percent, likely at a time when water is most urgently needed. Careful management of aquifer storage has the potential to increase reliability of water supply by reducing the time when withdrawals are subject to CPM reductions. There is also the potential for increasing the total amount of pumping from the aquifer on a sustained basis. In addition, if ongoing enhanced recharge is capable of keeping regional water levels above normal going into a drought, the impacts of drought conditions may be lessened. Strategies could result in a fuller utilization of the shared resource than is currently possible. This minimizes the strain of importing additional water supply from regions where impacts to others are often less

easily mitigated. Importantly, it provides more local control of an area over its own water supply.

1.3. SCOPE OF WORK

To meet project goals, an R&R Phase III/IV scope of work was developed by EAA in consultation with Todd Engineers. The scope built on previous R&R work conducted by Todd Engineers as Phases I and II, and, as such, was originally referred to as Phase III. The 2004 generalized scope of work for Todd Engineers envisioned Phase IV to consist of a comprehensive report. That phase was combined into this project resulting in this Phase III/IV report.

The project objective was to develop scenarios under which the Edwards Aquifer, functioning as a reservoir, could meet water supply delivery and Comal Springs habitat requirements by means of R&R under assumed future conditions. The analysis relied on EAA specification of:

- location and magnitude of future pumpage as a function of time;
- minimum Comal Springs flow requirements;
- Critical Period Management (CPM) rules of the EAA applied to withdrawal permits; and
- applicable EAA Aquifer Recharge Storage and Recovery (ARSR) rules.

The analysis incorporated newly-developed amounts of source water that could be available for enhanced recharge and evaluated R&R components and scenarios using the Edwards Aquifer MODFLOW groundwater computer model (EAA model) developed for EAA by the U.S. Geological Survey (USGS) and others (Lindgren, et al., 2004). Specifically, the EAA model was used to evaluate:

- locations of enhanced recharge;
- quantity of water to be recharged;
- locations and efficiency of enhanced recharge recovery/injection (recirculation) wells; and
- quantity of water to be pumped for recirculation using ARSR rules.

The scope of work was organized into five main tasks as listed below.

- Develop baseline scenario
- Evaluate R&R facility operational parameters
- Evaluate source water availability and conduct scenario modeling
- Determine facilities needed for scenarios and estimate costs
- Prepare report in required regional water plan format

Specific requirements for modeling assumptions and scenario development were also included in the scope. For example, certain evaluations specified Comal Springs flow to be above 40 cfs or 150 cfs. All evaluations incorporated triggers for withdrawal reductions when Comal Springs, San Marcos Springs, or index wells fell below the critical period stages or water levels defined by EAA CPM rules. Applicable EAA rules, including CPM withdrawal reductions are described in Chapter 2 of this report. The complete Phase III/IV scope of work is provided as Appendix A.

The original schedule for the Phase III/IV work was estimated at nine months, but that time period proved insufficient for evaluation of all project components. Although the Phase III/IV contract was approved and signed in August 2006, the project was put on hold until mid-2007 while legislative changes were being developed that impacted EAA aquifer management rules. Legislative modifications on pumping limits and subsequent revisions to CPM rules had to be incorporated into the EAA model and the surface water availability model, resulting in further schedule delays. This draft report is being provided in October 2008 in accordance with a revised agreed-upon schedule with EAA.

1.4. USE OF NUMBERS

Throughout this report, areas are shown to the nearest acre, and water budget components are shown to the nearest acre-foot (AF). As a result, large numbers may appear to be accurate to four or more significant digits, which is not the case. Values for data that are measured directly, such as water levels, springflow, and groundwater pumping, are probably accurate to two or possibly three significant digits. Values for data that are estimated, such as water budget amounts simulated from the groundwater model, may only be accurate to one or two significant digits. All digits are retained in the text and tables to preserve correct column totals in tables and to maintain as much accuracy as possible when converting units or conducting subsequent calculations.

1.5. ACKNOWLEDGEMENTS

This study was accomplished through teamwork by the three-firm consulting team of Todd Engineers, TRC/Brandes, and NRS Consulting Engineers. For Todd Engineers, Phyllis Stanin served as project manager and Maureen Reilly led the groundwater modeling. Both were supported by additional technical and support staff of the firm. Bob Brandes and Kirk Kennedy of TRC/Brandes conducted the surface water modeling, updating and refining the WAM and developing techniques for the analysis of available source water for diversion and/or recharge. Bill Norris of NRS Consulting Engineers provided technical direction for project engineering, Mike Irlbeck managed the project, and both were assisted by a team of engineers for developing facilities and costs for the management strategies.

Several EAA staff members provided key roles in managing the project and assisting with technical information. Project management roles were shared by Len Wagner and Rick

Illgner. Ms. Wagner provided early project management and guidance on S.B. 3 amendments and assisted in developing baseline conditions. Rick Illgner managed the project, provided technical assistance, and developed key data on the unused Edwards Aquifer permits. Geary Schindel and his Aquifer Science team provided information on recharge locations, the EAA model, and methods for managing numerical problems with the model such as dry cells. The team also benefited from direction and support by EAA current and previous General Managers, Velma Danielson and Robert Potts. John Hoyt assisted in the development of the scope of work.

The study builds on the strong technical analyses by others that developed most of the R&R strategies to date. In particular, the firms of HDR Engineering, LBG-Guyton and Associates, and Paul Price Associates developed much of the work relied on in this phase. In addition, a key investigator, Sam Vaugh of HDR Engineering, was particularly helpful in explaining previous methods and providing information on recharge pool sizing. Mr. Vaugh also provided his electronic data files containing recharge totals at Type 2 sites.

2. CONCEPTS OF RECIRCULATION

Geologic and hydrogeologic investigations of the Edwards Aquifer have been conducted for more than 100 years (EAA, 1998). The improved understanding of the groundwater system afforded by these investigations has served as the foundation for groundwater management strategies developed over the years. It also forms the basis of the EAA model used in this analysis. Some of the basic concepts of the aquifer related to the evaluation of R&R management strategies are summarized below to provide context for the analysis in this report.

The areal extent of the Edwards Aquifer is illustrated by the map on Figure 1-1. The area where the Edwards Limestone is exposed at the surface is the recharge zone (Figure 1-1). Almost all of the natural recharge from infiltrating rainfall and streamflow occurs here. Water percolates downward through the fractures, faults, bedding plane partings, and conduits in the aquifer until reaching the water table at varying depths below the surface. Large volumes of water from streams and runoff cross the recharge zone and contribute to natural recharge. Natural recharge occurs absent any management strategies and has been shown to represent very large volumes of water (LBG-Guyton, et al., 2005; EAA, 2007). For this study, enhanced recharge is defined as the recharge resulting from R&R strategies that is above the amount of recharge that would have occurred naturally at any given location.

As the entire aquifer dips south below the ground surface away from the recharge zone, the aquifer system becomes confined. In this confined zone, groundwater exists under pressure controlled by the elevation of the water table in the unconfined recharge zone. Moving from high pressure to low pressure, groundwater is ultimately discharged from the aquifer through wells, springs, and subsurface outflow at aquifer boundaries.

Spring discharge occurs when the pressure surface in the confined aquifer is above the ground surface and conduits are present to allow the water to be transmitted to the surface. The higher the pressure surface is above the ground, the greater the flow of the springs. Such conditions exist at Comal and San Marcos springs, where ground surface elevations are relatively low and the pressure surface typically occurs above these elevations. During the drought of record in 1956, the pressure surface at Comal Springs fell below the ground surface for a period of five months causing the spring to be dry. Other than that brief period, springflow has occurred on a continuous basis.

Natural recharge occurs in the unconfined unsaturated zone, raising water levels in the recharge area. Higher water levels here result in a pressure response in the confined portion of the aquifer. Although the pressure wave is propagated through the aquifer relatively quickly, there is a time lag before spring discharge increases in an amount equivalent to recharge. During this time lag, the recharged water adds to groundwater storage. Managing the aquifer for storage requires some understanding of this time lag and pressure response.

The fate of water recharged into the aquifer is time- and location-dependent, and at various times can occur as:

- groundwater storage
- discharge to springs (Comal Springs and other springs)
- discharge to pumping wells.

For the simulations of management strategies in this study, the fate of the recharge water is represented as bar graphs, indicating the location of enhanced recharge water after a certain time period. An example of such a graph is shown schematically below.

Illustration 2-1: Example Bar Graph Illustrating the Fate of Recharged Water.

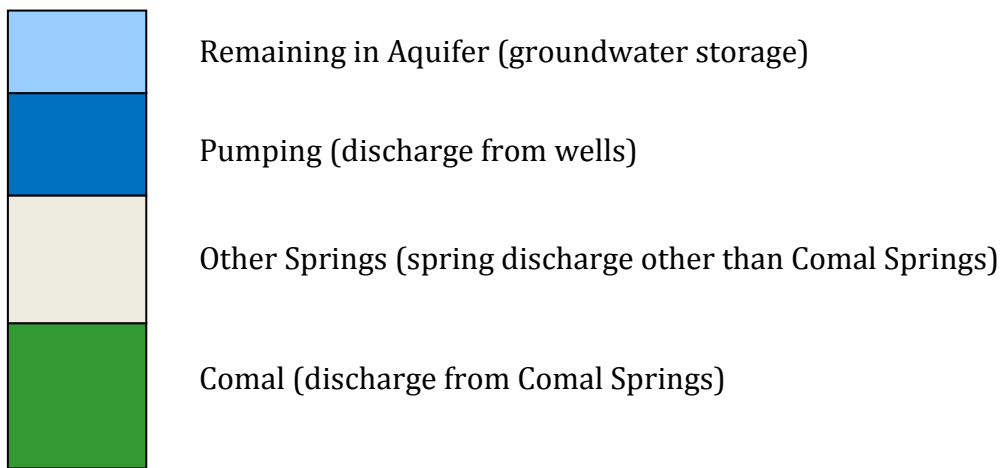

In order to assist the reader in the evaluation of benefits and to compare various model results, the nomenclature and color scheme above is maintained throughout the graphs in this report, where appropriate. This presentation visually illustrates the portion of the recharge water that benefits aquifer storage, wells, or springs.

Heterogeneities in the aquifer system have been observed to attenuate or re-direct groundwater flow, potentially delaying the pressure response at springs and increasing groundwater storage. One such area is in southeastern Uvalde County where a subsurface bedrock high, referred to as the Uvalde salient, and other structural complexities have resulted in reduced saturated thickness in the aquifer (Green, et al., 2006). This restriction to flow re-directs eastward-flowing groundwater to the north through a relatively narrow trough between subsurface highs, referred to as the Knippa Gap. This process is thought to be one of the controlling factors for flow out of Uvalde County and into the San Antonio Pool. Another area of heterogeneity is the fault complex in western Medina County, including the Haby Crossing Fault, where flow is thought to be re-directed along fault blocks. This impedance is thought to slow the pressure response of recharged water on downgradient springs. East of this zone, water entering the unconfined aquifer may create

a more immediate response at key springs. These heterogeneities provide potential opportunities to manage the aquifer alternatively for storage or springflow maintenance.

Previous engineering work on enhancing recharge defined two types of recharge structures that could be built for the purposes of capturing and recharging excess streamflow. One type of structure consists of an upstream dam that captures water upstream of the recharge zone and pools the water in a reservoir. Over time, that water can be released back to the stream channel where it flows downstream and infiltrates upon reaching the more permeable recharge zone. With this structure, referred to as a Type 1 structure, pooled water can be released as needed, thereby controlling the timing of water available for recharge. Due to the location of these structures on the upstream side of the recharge zone, Type 1 sites on prospective streams are typically named “upper” (e.g., Upper Seco). An example of a Type 1 facility is shown below.

Illustration 2-2: Types of Enhanced Recharge Structures

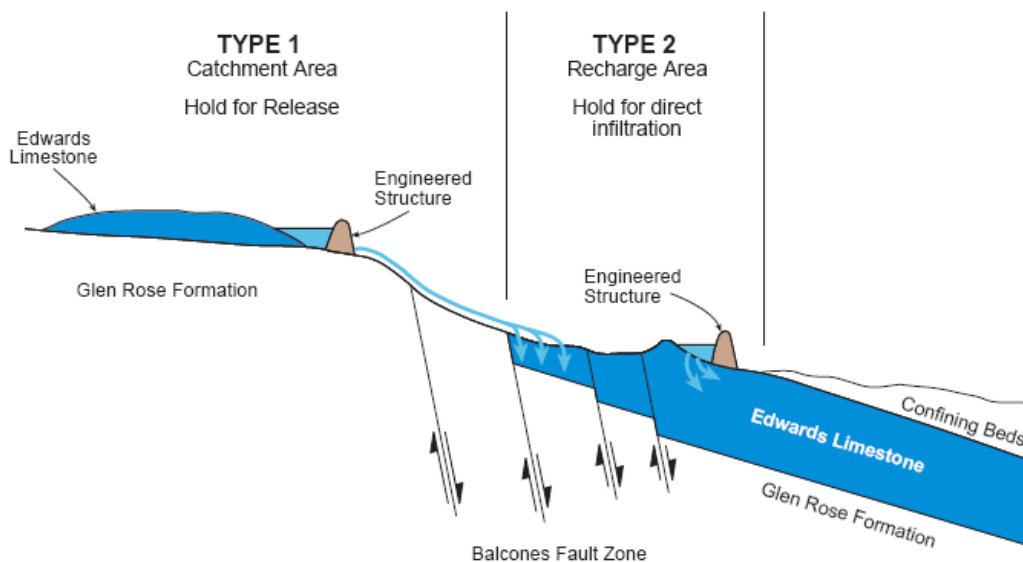

After HDR, et al., 1991

Type 2 structures consist of in-stream dams constructed typically in the downstream portion of the recharge zone. These structures simply hold excess streamflow on top of the recharge zone, allowing more water to infiltrate than would otherwise. Field investigations have documented rapid percolation rates of 2 to 3 feet per day at several sites and Type 2 reservoirs are envisioned to be dry most of the time. With one exception, the recharge sites analyzed in this study are Type 2 (or direct recharge) projects.

Since baseflows downstream of the recharge zone are rare, flood flows are typically the only water available for enhanced recharge (HDR, et al., 1991). This presents operational challenges since, during flood flows, large volumes of water would need to be captured. This requires large structures that are only rarely used.

2.1. PREVIOUS INVESTIGATIONS ON R&R STRATEGIES

The work presented in this Phase III/IV report builds on prior investigations that have identified and evaluated groundwater management strategies since the early 1990s. The progression of analysis is summarized for context below. Technical details on specific sites, volumes of water, environmental considerations, and costs are not repeated, and the reader is referred back to the original document cited for more information.

2.1.1. RECHARGE ENHANCEMENT STUDIES

Potential enhanced recharge sites along the recharge zone of the Edwards Aquifer have been studied for more than 40 years. In 1964, the U.S. Army Corps of Engineers (USCE) identified several projects where flood control and recharge enhancement could be combined (HDR, et al., 1993). Certain recharge enhancement/flood control projects were constructed, but the first comprehensive evaluation focused on enhancing aquifer recharge began in the early 1990s with assessments of potential recharge sites on streams in both the Nueces and Guadalupe-San Antonio (GSA) river basins.

NUECES RIVER BASIN

In 1990, EUWD, along with Nueces River Authority, City of Corpus Christi and the South Texas Water Authority, commissioned a multi-phase assessment of potential recharge enhancement projects on streams in the Nueces River Basin (HDR, et al., 1991). Potential Type 1 and Type 2 projects were identified along drainages crossing the recharge zone including Indian Creek, Dry Frio River, Frio River, Leona River, Sabinal River, Seco Creek, Parkers Creek, Hondo Creek, Verde Creek, and Elm Creek. Storage volumes, available streamflow for recharge, and preliminary costs were developed for 19 projects. The sizing of recharge pools was optimized based on available water and incremental costs for capturing certain portions of the recharge water. Since none of the streams typically exhibited continuous base flows across the recharge zone, flood flows were the main source of available recharge water. Certain projects were eliminated (e.g., Lower Seco) due to a lack of sufficient flood flow that was not already being recharged. Based on this optimization, six Type 2 projects were recommended as the preferred recharge enhancement program including, from west to east, Indian Creek, Lower Dry Frio, Lower Frio, Lower Sabinal, Lower Hondo, and Lower Verde. The results of this work represented HDR Phases I – III of the recharge enhancement study and were documented in late 1991 (HDR, et al., 1991).

HDR Phase IV work on the Nueces Basin recharge sites was continued solely by EUWD to perform a more detailed evaluation of the six Type 2 sites identified in Phase III (HDR, et al., June 1994). In this phase, two projects, Indian Creek and Lower Dry Frio, were eliminated from the recommended recharge enhancement program. For the Indian Creek project, potential limited infiltration rates and uncertainties associated with the pathway of

the recharge water were noted. These concerns led HDR to propose pumping approximately 2,000 AF/month of the water captured by the Indian Creek recharge structure to the nearby Dry Frio River to take advantage of the higher infiltration rates at that site. This project, referred to as the Indian Creek pump-over, was noted as promising but was not recommended until after development of the four more promising sites. In addition, insufficient streamflow was available on the Dry Frio River to independently justify the construction of a Type 2 structure and, as such, this structure was also dropped from the recommended program. The recommended program, including optimal size, is summarized below.

Table 2-1: Recommended Recharge Enhancement Program for the Nueces River Basin

Type 2 Project	Optimal Capacity (AF)	Recharge Enhancement (AFY)	
		Average Conditions	Drought Conditions
Lower Frio	17,500	17,064	3,980
Lower Sabinal	8,750	16,442	2,358
Lower Hondo	2,800	6,779	1,193
Lower Verde	3,600	4,850	1,719
Total	32,650	45,135	9,250

After HDR, et al., June 1994

GUADALUPE – SAN ANTONIO (GSA) RIVER BASIN

To supplement the recharge enhancement projects on the Nueces River Basin, EUWD began study on potential Type 2 sites in the GSA River Basin with the initial work being documented in 1993 (HDR, et al., 1993). In addition to the identification of additional recharge enhancement sites, the study also examined water rights and downstream uses on the Guadalupe River, updated groundwater recharge estimates from streams in the basin, and constructed a river basin model capable of simulating streamflow from 1934-1989 (HDR, et al., 1993). Enlargement of existing recharge structures was also considered including floodwater retention structures (FRS) constructed for flood control only. One Type 1 structure (Cloptin Crossing), two new Type 2 structures (Cibolo Dam and Lower Blanco), and enlargement/or operational changes for six smaller Type 2 sites across the basin were evaluated (HDR, et al., September 1993). Ultimately the Cibolo Dam, Lower Blanco, and San Geronimo sites were added to the regional recommended recharge enhancement program. Optimal sizing and yield associated with these sites as developed by HDR are summarized in Table 2-2 below.

Table 2-2: Recommended Recharge Enhancement Program for the Guadalupe-San Antonio (GSA) River Basin

Type 2 Project	Optimal Capacity (AF)	Recharge Enhancement (AFY)	
		Average Conditions	Drought Conditions
San Geronimo	3,500	3,128	645
Cibolo Dam	10,000	9,733	1,485
Lower Blanco	50,000	49,766	22,490
Total	63,500	62,627	24,620

After HDR, et al., 1998

TRANS-TEXAS WATER PROGRAM AND REGIONAL WATER PLANS

As a continuation of the 1990 Texas Water Plan, the Texas Water Development Board (TWDB) initiated the Trans-Texas Water Program as a regional planning process involving eight sponsors including the EUWD. The West Central Study region covered 33 counties and the major population centers of San Antonio, Austin, San Marcos, New Braunfels, Round Rock, Victoria, and Seguin. Phase I of the process evaluated water demand and water supply strategies to meet the increasing demand (HDR, et al., May 1994).

The recharge enhancement projects identified by EUWD and HDR in previous studies were incorporated into the water supply alternatives of the Trans-Texas planning process and designated as local alternatives L-17 (Type 1 recharge structures) and L-18 (Type 2 recharge structures). The L-18 alternative included the four sites in the recommended program for the Nueces River Basin (Lower Frio, Lower Sabinal, Lower Hondo, and Lower Verde), plus Indian Creek. Also included were the three main Type 2 sites in the GSA River Basin (San Geronimo, Cibolo Dam, and Lower Blanco), plus additional smaller sites in northern Bexar County (Leon/Helotes/Government Creek). The technical evaluation of L-18 included additional documentation on environmental issues, yields, and costs (HDR, et al., May 1994).

In addition to enhancing recharge by capturing flood flows in streams across the recharge zone, the Trans-Texas process also identified alternatives involving the diversion of surface water from the Guadalupe River and conveyance of that water back to the recharge zone (HDR, et al., May 1994). These alternatives were further evaluated in Volume 4 of the Trans-Texas Phase I documents and included the following diversions from the Guadalupe River:

- Diversion near Comfort and conveyance to the recharge zone via Medina Lake (G-30)
- Diversion from Canyon Lake and conveyance to the recharge zone via Cibolo Creek (G-32)
- Diversion from Lake Dunlap and conveyance to the Type 2 sites in northern Bexar County (G-33)

Yield, environmental issues, water treatment, engineering, costs, and implementation issues were addressed for these water supply strategies (HDR, et al., 1995).

Completion of the recharge enhancement study that began in the early 1990s was included in the second phase of the Trans-Texas Water Program (HDR, et al., 1998). The objective of the study was to develop an appropriate program of Type 2 recharge enhancement projects by more accurately evaluating recharge potential, conducting flood hydrology modeling at four major projects, and optimizing size of the individual projects. The study also included an evaluation of a Type 1 structure on the Upper Blanco River (HDR, et al., 1998). Project ranking was conducted based on costs per unit recharge enhancement for average hydrologic conditions. The recommended program for implementation included seven of the previously-evaluated Type 2 sites (Lower Frio, Lower Sabinal, Lower Hondo, Lower Verde, San Geronimo, Cibolo Creek, Lower Blanco) (L-18A). The L-18 program (including slight modifications and phasing) was adopted by the SCTRWPG for the Region L Water Plan in 2001 and 2006 for implementation in 2010.

2.1.2. RECIRCULATION STUDIES

The concept of recirculation, as first evaluated, involved diverting a portion of water in the Guadalupe River that originates as springflow back to the recharge zone (HDR, et al., March 1998). The idea was to increase groundwater storage in the aquifer during times of high springflow so that the stored water could sustain springflow and pumping during drought conditions.

Recirculation of up to 200 cfs and 400 cfs was evaluated during two GWSIM IV model runs. Diversions of springflow were dependent on key well water levels and available springflow. In the simulations, water for the first 200 cfs was recharged at the northern Bexar County Type 2 sites. For the additional 200 cfs in the 400 cfs run, water was recharged to the recharge zone in northern Medina County. Results were compared back to a baseline pumping scenario of 400,000 AFY. The recirculation scenarios indicated that springflow at Comal Springs would increase as a result of recirculation. Importantly, the time periods where the springs were at critically low flows decreased as well. Although Comal Springs had ceased to flow for 2.75 years during the drought of record for baseline conditions, that time period decreased to 0.5 years for the 200 cfs recirculation scenario and flowed continuously for the 400 cfs recirculation scenario. Recirculation also had demonstrable benefits for water supply. Sustained pumping could be increased about 87,000 AFY and 118,000 AFY over baseline pumping for the 200 cfs and the 400 cfs scenarios, respectively.

Recharge and recirculation strategies were evaluated further by the SCTRWPG in 2001 as an alternative strategy in the Region L Water Plan (SCTRWPG, January 2001). The evaluation included groundwater model simulations of four scenarios involving the recirculation of springflow attributed to enhanced recharge from Lake Dunlap back to the

recharge zone in Bexar, Medina, and Uvalde counties. All four scenarios diverted flows up to 600 cfs. One scenario transferred all of the recirculation water to the Cibolo Type 2 site when springflow was below 150 cfs. Two scenarios used groundwater as an additional supply of recharge water to be pumped from new wells in Uvalde County and transmitted to recharge sites at Cibolo and western Bexar County as dictated by springflow¹.

Benefits to Comal Springs and sustainable pumping were estimated. Although project costs were high (all scenarios in excess of \$1.1 billion), costs per AF of available water ranged from \$632/AF to \$1,141/AF². The scenarios had other water supply strategies incorporated and used a now-outdated baseline. Because of operational uncertainties and other factors, the R&R alternative water plan was not recommended. As such, R&R was identified as a potential water management strategy that requires further study and funding by both the 2001 and 2006 Regional Water Plans (SCTRWPG, 2001; 2006).

2.1.3. TODD ENGINEERS R&R PHASES I AND II

In April 2004, EAA contracted with Todd Engineers to conduct a multi-phase study on enhanced recharge and recirculation (R&R) strategies. The analysis was divided into four phases. Phase I of that work was completed in September 2004 (Todd Engineers, 2004), followed by Phase II completed in May 2005 (Todd Engineers, 2005). These previous phases established the use of a newly-developed groundwater model as a tool to evaluate enhanced recharge strategies and focused on the effect of the enhanced recharge on maintaining springs above critical flow levels.

The Phase I study included a review of existing studies, an analysis of Edwards Aquifer hydraulics, installation and operation of the USGS MODFLOW groundwater model of the Edwards Aquifer (referred to herein as the EAA model), and application of the model for test runs at two hypothetical recharge sites. The Phase II study analyzed the magnitude and duration of increased springflow from enhanced recharge at eight Type 2 sites. Objectives for Phase II included a comparison of impacts on a site-to-site basis for both a single recharge event and yearly enhanced recharge over time. Results of the scenarios indicated that increases to water supply and springflow varied with location and volume of recharge. Sites in the west provided less flow to Comal Springs but recharge remained in the aquifer for longer periods of time, contributing to groundwater storage. Sites in the east contributed more significantly to springflow at Comal and San Marcos springs and resulted in relatively small amounts of groundwater storage. Recharge at the easternmost site, Lower Blanco, contributed mainly to San Marcos Springs with limited flow to Comal Springs. Recharge to sites in the central area of the basin showed moderate increases to Comal Springs and groundwater storage. In the Phase II analyses, all of the groundwater

¹ It is our understanding from the most recently adopted EAA rules that these types of cross-county pump-overs are now prohibited for Uvalde and Medina counties (EAA, 2008).

² Costs are in 2006 dollars

model applications were compared to a baseline consisting of the unmodified USGS model. Only limited analysis was done on the combination of the effects of enhanced recharge and CPM rules. Recirculation options were not evaluated.

Phase III builds on the foundational work of Phases I and II to evaluate operational parameters, water sources for recharge, and conceptual costs for various R&R scenarios. A new baseline scenario was developed that reflects changes to the total permitted amount of pumping and newly-adopted critical period management rules. Phase II results were updated to reflect new baseline conditions. R&R scenarios were developed that considered source water availability as evaluated with the WAM surface water model. Preliminary costs were determined for scenario components.

This report describes the Phase III work and represents Phase IV of the R&R study. It was prepared with consideration of the State guidelines for regional water plan development (planning guidelines) to allow R&R to be considered for the Region L Regional Water Plan (TWDB, February 2008; March 2008).

2.2. EAA RULES

EAA was created by the Texas State Legislature to provide regional management of the Edwards Aquifer, declared to be a distinct natural resource of the State (Texas State Legislature, 1993). The EAA boundaries were defined as all of Bexar, Medina, and Uvalde counties and portions of Comal, Caldwell, Hays, Guadalupe, and Atascosa counties. The enabling Act provides for the organization and rule-making procedures for effective groundwater management.

To implement the Act, EAA has adopted rules regarding procedures, groundwater withdrawals, fees, water quality, comprehensive water management, and enforcement (EAA, 2008). The rules define two designated pools in the aquifer: the Uvalde Pool defined by the boundaries of Uvalde County and the San Antonio Pool underlying the boundaries of the EAA other than Uvalde County. Various rules apply differently to the two pools.

2.2.1. CRITICAL PERIOD MANAGEMENT (CPM) RULES

For the protection of ecosystems and other downstream uses, EAA has adopted rules for a Critical Period Management (CPM) Plan that reduces pumping during times when water levels and springflow are at critically low levels (EAA, 2008). The rules define critical period stages, triggers, and associated requirements for withdrawal reductions.

These CPM rules have been revised by recently-adopted amendments to the EAA Act in Senate Bill No. 3, Article 12 (S.B. 3) (Texas State Legislature, 2007). These amendments raised the cap on annual withdrawal permits from 400,000 AFY to 572,000 AFY by eliminating previously-designated Junior and Senior withdrawal rights. Current CPM rules (as amended by S.B. 3) set certain triggers that initiate four critical period stages in the two

aquifer pools (San Antonio Pool and Uvalde Pool). Triggers for the San Antonio Pool include the 10-day average daily springflow at Comal Springs and San Marcos Springs and water levels in Index Well J-17. For the Uvalde Pool, CPM reductions are triggered by water levels in Index Well J-27. During each of four critical period stages, management rules are in effect to reduce pumping by certain percentages of the total Permit pumping (withdrawal reductions). A summary of these rules with stages, triggers, and withdrawal reduction requirements is provided in the table below.

Table 2-3. EAA Critical Period Management (CPM) Rules

Critical Period Stage	San Antonio Pool				Uvalde Pool	
	Comal Springs (cfs)	San Marcos Springs (cfs)	Index Well J-17 (ft, msl)	Withdrawal Reduction (%)	Index Well J-27 (ft, msl)	Withdrawal Reduction (%)
I	<225	<96	<660	20%	NA	NA
II	<200	<80	<650	30%	<850	5%
III	<150	NA	<640	35%	<845	20%
IV	<100	NA	<630	40%	<842	35%

Source: EAA, 2008

2.2.2. AQUIFER RECHARGE, STORAGE, AND RECOVERY (ARSR) RULES

To control and manage augmentation of the aquifer for water supply and springflow, EAA has developed and adopted rules relating to groundwater recharge projects such as those being evaluated in this Phase III/IV report. The ARSR rules address acceptable methods of recharge, permissible sources of recharge water, acquisition of ARSR permits, and other provisions. ARSR permits can be acquired to increase water withdrawn from the aquifer for beneficial use or to maintain/increase springflow of Comal or San Marcos springs.

Both surface water and groundwater can be used for enhanced recharge projects, subject to rules and restrictions on particular sources and locations. For example, there are restrictions on recharging groundwater from an aquifer other than the Edwards Aquifer if that aquifer has been designated as a priority groundwater management area. In addition, groundwater withdrawn in Uvalde County cannot be transported to a recharge project outside of Uvalde County. A similar restriction is in place for Medina County. Various provisions protect current surface water rights and downstream uses. For example, streamflow cannot be diverted for recharge if already appropriated. In addition, the definition of a recharge facility does not include a facility to recirculate water at Comal or San Marcos springs.

EAA rules allow any person owning (or proposing to construct) a well within EAA boundaries to apply for a recharge recovery permit. Such a permit allows the holder to

pump the amount of enhanced recharge water less any losses to springflow or other aquifer discharge. Further, the permit provides that pumping to recover recharge is not subject to withdrawal reductions of CPM rules. The increase in pumping cannot unreasonably negatively affect other permittees including those holding regular withdrawal permits. In addition, required minimum springflows cannot be adversely impacted beyond conditions that would have occurred if the recharge/recovery project did not exist.

2.3. APPLICATION OF THE USGS MODFLOW MODEL

Phases I, II, and III evaluate various R&R management strategies using the Edwards Aquifer MODFLOW numerical model (EAA model) developed by USGS and others (Lindgren, et al., 2004). The EAA model is a calibrated transient model. The simulation period begins with initial head conditions generated from a steady state simulation of 1946 conditions and continues as a transient model for 1947-2000 with monthly stress periods. The original model estimated hydrologic conditions and pumping on a monthly basis throughout the transient period. For the Phase III study, the original model's hydrologic conditions were used but pumping was adjusted to represent the current Permit pumping in the aquifer (572,000 AFY).

Due to large file sizes, USGS originally divided the transient EAA model into two halves to allow it to work with pre- and post- processors. The first half of the model (1946-1973) covers much drier hydrologic conditions than the second half (1973-2000), with approximately 30 percent less natural recharge. In the first half of the model, the aquifer is subject to CPM withdrawal reductions for 85 percent of the time (278 months) compared to only 44 percent of the time in the second half of the model (144 months). These differences in recharge and length of time in critical period affect the yield of enhanced recharge. Results from the two model halves are often examined separately in the Phase III study to show the long-term response of the aquifer to enhanced recharge and recirculation strategies under dry and average/wet hydrologic conditions.

In order to simulate EAA CPM rules, HydroGeoLogic, Inc. (HydroGeoLogic) developed computerized management modules to work in concert with the USGS model. These modules read in model output such as head and springflow for assigned triggers as the model is running. Based on the values of these triggers, the management modules can adjust pumping by use or by pool, thereby simulating withdrawal reductions associated with CPM requirements. Recently-adopted CPM triggers and rules are set up in the modules and applied to the EAA model for each simulation in the Phase III study.

For more information about the original model, the reader is referred to the USGS model documentation (Lindgren, et al., 2004). For more information about the management modules, the reader is referred to the documentation prepared by HydroGeoLogic (HydroGeoLogic, 2004 and 2005).

The EAA model, like any numerical model, is a simulation of the actual natural system and has certain limitations. Although the model represents a much-improved predictive tool with which to analyze R&R scenarios, numerous uncertainties are associated with both the model and the applications for this study. The model uncertainties and limitations were summarized in the Phase I report and are briefly re-stated here to highlight model application issues. For Phase III, modifications were made to the model, which are also subject to limitations. The model was applied to evaluate potential future impacts rather than historical data. Notably, a new pumping package was created to reflect the total permitted pumping (572,000 AFY), new CPM rules, and new initial conditions.

To simulate current and future pumping, pumping totals were increased above the original EAA model pumping amounts. This increase in pumping may stress the boundary conditions outside the range for which the model was calibrated. The result is that a larger portion of the model may now be subject to cells going dry due to numerical problems than occurred in the original model. For all Phase III simulations, the USGS re-wetting tool was used to prevent this numerical instability. The problem and solution are discussed further in Chapter 3 relating to developing a baseline scenario.

In addition to the dry cell problem, changes in the distribution of pumping may have other unintended consequences. When updating the EAA model, recharge and pumping rates were selected independently to reflect what may happen in the future rather than what has occurred in the past. Although recharge and pumping are decoupled in the model, in reality the amount of recharge (and precipitation) would have a direct influence on the total amount of pumping. For example, wet conditions would likely result in less pumping as precipitation satisfies more of the irrigation water demand; similarly, in dry conditions, more water would likely be pumped for irrigation. By assuming pumping is always at the permitted limit, the total demand may be over-estimated.

As stated in the previous reports for Phases I and II, the EAA model has other limitations that should be considered when developing scenarios and analyzing model results. Two key limitations are stated below:

- The model provided a better calibration of the confined zone than the recharge zone, and predictions of head in the recharge area may be less reliable.
- The EAA model is a porous media model used to simulate a dual-porosity karst system. The model cannot simulate turbulent flow occurring in the conduits. In addition, locations of the simulated conduits have a strong impact on the areas surrounding the conduits. While the model can predict regional variations in water levels and springflow, it probably should not be used to predict the fate and transport of particles of water or contaminants.

Notwithstanding these limitations, the model is a valuable tool to examine volumetric flow responses in the confined zone, particularly at the major springs. Although enhanced recharge will be added in the recharge zone, the effects are measured in the confined zone

through spring discharge and water levels at selected index wells (J-17 and J-27). The observed spring discharge for Comal Springs was well matched by the simulated discharge in the original model. Because simulations are consistent with the regional design of the model, scenario results are expected to fall within the range of model capabilities.

3. BASELINE SCENARIO DEVELOPMENT

Groundwater and surface water conditions under R&R management strategies need to be compared against some standard set of conditions in order to quantify the associated benefits. This standard, or baseline, should reflect groundwater and springflow conditions that would occur absent the management strategies being evaluated. This type of analysis isolates the strategy impacts from the normal variability in natural hydrologic conditions.

Previous evaluations have involved a variety of baseline conditions with numerous assumptions for pumping, water conservation, irrigation transfers, and CPM rules. None of the published evaluations reviewed for this study have applied the recent changes to CPM rules as amended by S.B. 3 (Texas State Legislature, 2007) or the recently-available EAA groundwater model (Lindgren, et al., 2004) to a baseline analysis.

For this study, a baseline scenario was developed using the EAA model and incorporating the new pumping cap and CPM rules for the model period of record. Springflow output from the model was also used to develop a new baseline scenario for the surface water model. The baseline scenario conditions and results were provided to EAA in August 2007 for approval prior to proceeding with this study. The development of the baseline scenario and results are summarized in this chapter.

3.1. MODIFICATIONS TO EAA MODEL

The baseline scenario reflects current conditions (including permitted withdrawals) without R&R management strategies. Baseline development required revision of model input files to reflect total permitted pumping, application of CPM rules (recently amended by S.B. 3), and “firm yield” as defined by Region L and re-affirmed by S.B. 3³ (Texas State Legislature, 2007; EAA, 2008). Time periods representative of wet, dry, and average hydrologic conditions are selected from the baseline scenario for model run comparisons.

Specific model changes involved increased pumping to a maximum permitted withdrawal amount of 572,000 acre-feet per year (AFY), revised trigger levels for staged withdrawal reductions, and the elimination of the Junior/Senior permit rights designation. Each of these changes was accommodated through changes to the MODFLOW well file and management modules as described in more detail below.

3.1.1. WELL FILE MODIFICATION

The distribution and amount of pumping in the original MODFLOW model were based on estimates of actual pumping from 1947 to 2000, the transient period of record for the

³ Defined as 340,000 AFY

model. These data document the increase in pumping over time from about 120,000 AFY in 1940 to about 570,000 AFY in the late 1980s as illustrated below.

Illustration 3-1: Original Pumping from the MODFLOW Model

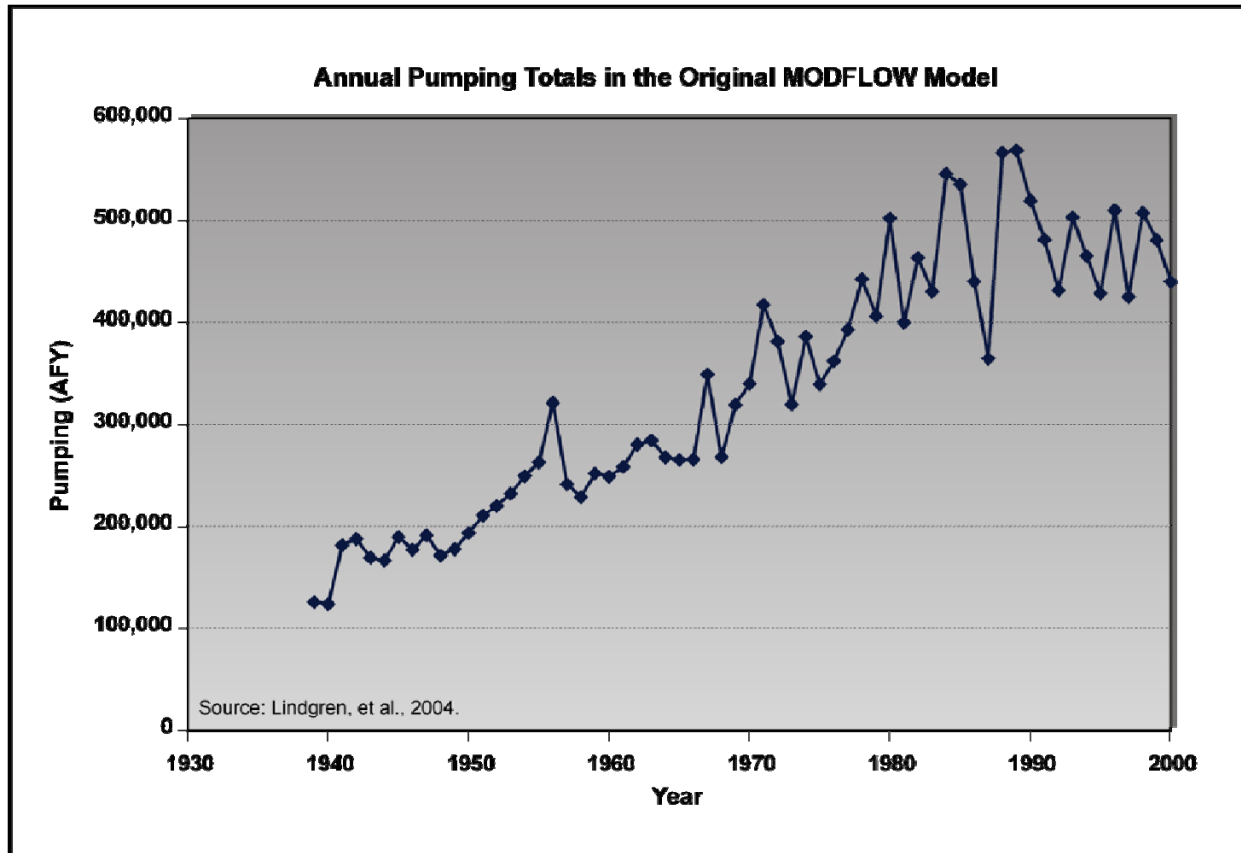

With the amended permitted withdrawal cap set currently at 572,000 AFY, the model was applied with continuous pumping amounts equivalent to the maximum amount in the original model.

The MODFLOW well file that was modified for the baseline scenario was originally based on the 2005 annual permit totals from EAA, other domestic wells in the study area, and the wells along the Trinity-Edwards border that simulate the constant flux boundary in the model. The total pumping amount associated with EAA permits in this file totaled 541,997 AFY and included permits that were designated as either “Junior” or “Senior” with respect to withdrawal rights. To comply with the amended CPM rules, all Junior rights were converted to Senior rights and the allocated pumping was increased by a factor of 1.055 to simulate the new pumping cap of 572,000 AFY.

Because well permits provide for pumping on an annual basis and the model evaluates hydrologic conditions monthly, the annual pumping for each well was re-distributed on a monthly basis. This distribution is based on an analysis by LBG-Guyton that correlated the

distribution of monthly pumping to well type. The percentage of total pumping that is allocated to each month for municipal, industrial, and agricultural wells is listed in Table 3-1, and illustrated by a graph of the table data.

Table 3-1: Distribution of Annual Pumping on a Monthly Basis by Water Use

Pumping by Water Use			
Month	Municipal (% Annual)	Industrial (% Annual)	Agricultural (% Annual)
January	6.9%	8.3%	1.1%
February	6.4%	8.3%	1.5%
March	7.5%	8.3%	2.6%
April	8.0%	8.3%	5.7%
May	8.4%	8.3%	19.0%
June	9.1%	8.3%	29.0%
July	11.0%	8.3%	16.1%
August	11.1%	8.3%	9.9%
September	9.0%	8.3%	4.7%
October	8.4%	8.3%	5.2%
November	7.1%	8.3%	3.8%
December	7.1%	8.3%	1.4%
Total	100%	100%	100%

Illustration 3-2: Monthly Distribution of Pumping by Water Use

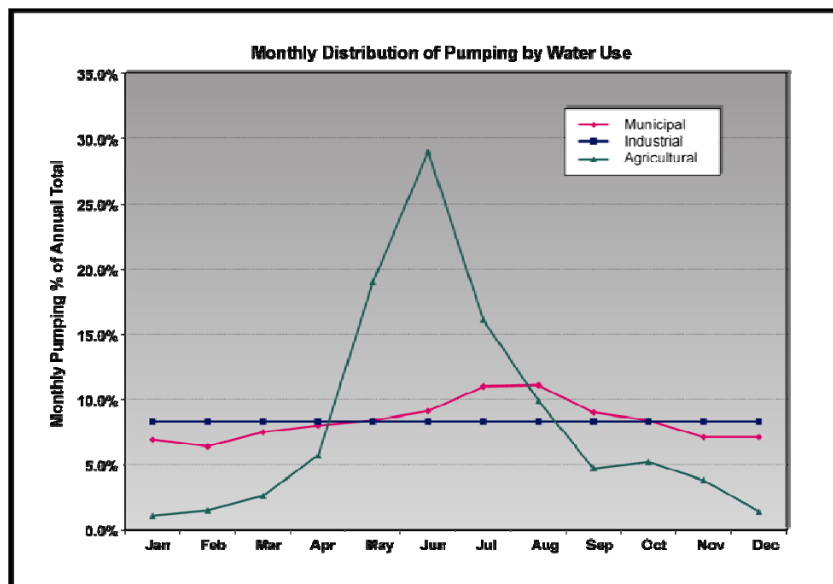

As shown in Table 3-1 and Illustration 3-1, agricultural use is higher in the late spring/early summer and lower during the winter months. Industrial use is assumed constant from month to month and municipal pumping is typically highest in late summer. This pattern was applied to annual pumping totals for wells in the well file. To format the modified well file for use in MODFLOW, a FORTRAN program created for EAA by LBG-Guyton was used.

3.1.2. INITIAL WATER LEVELS

In order to apply the new well file and CPM rules, initial water level conditions for the baseline had to be developed. In the original MODFLOW model, a steady state run was used to develop initial conditions for the transient model. The steady state run ensures that the hydrologic components of the model are internally consistent. For the baseline scenario, the water level output from the original MODFLOW steady state run was used as input to a steady state run for the baseline scenario. The pumping for the revised steady state period was based on the distribution and rates for the month of January under the new EAA pumping cap. This resulted in an annualized pumping total of 337,122 AFY, close to the firm yield of 340,000 AFY. Output from the revised steady state run was used as initial water levels for the transient model. The steady state run resulted in an initial water level for Index Well J-17 of 661 feet above mean sea level (msl), close to the long-term average of 663 feet msl.

3.1.3. AMENDED CRITICAL PERIOD MANAGEMENT RULES

To incorporate the revised CPM rules, the management modules developed by HydroGeoLogic were modified. The management modules allow designation of well uses (municipal, industrial, or agricultural), well pools, triggers (springs or observation wells), and various management rules, and automatically reduce pumping when trigger levels are reached in the simulations (HydroGeoLogic, 2004; 2005). Software tools developed by LBG-Guyton were used to create the management module files, assign pumping wells to the correct pools and uses, and designate the triggers and management rules in the modules. This new rule file was created by Todd Engineers based on CPM rules (as amended by S.B. 3 amendments) and reviewed by EAA staff for incorporation into the baseline scenario. CPM rules and associated withdrawal reductions are summarized in Table 3-2.

Table 3-2: Withdrawal Reductions under CPM Rules As Amended by S.B. 3

Critical Period Stage	San Antonio Pool		Uvalde Pool		Total Pumping (AFY)
	Pumping (AFY)	Withdrawal Reduction (percent)	Pumping (AFY)	Withdrawal Reduction (percent)	
	448,095		123,905		572,000
I	358,476	20%	123,905	NA	482,381
II	313,666	30%	117,710	5%	431,376
III	291,262	35%	99,124	20%	390,386
IV	268,857	40%	80,538	35%	349,395

Region L planning documents define “firm yield” as the “volume of water available for water supply from the aquifer during the drought of record.” In the 2006 South Central Texas Regional Water Plan, that amount was designated as 340,000 AFY for planning purposes (SCTRWPG, 2006). S.B. 3 re-affirms that amount and states that “the authority may not require the volume of permitted withdrawals to be less than an annualized rate of 340,000 acre-feet per year.” Although further reductions are allowed under certain conditions, the 340,000 AFY amount is viewed as the aquifer’s “firm yield” for the purposes of R&R analyses. As such, the baseline scenario was reviewed to ensure that pumping did not fall below this yield. As shown on the Table 3-2 above, this firm yield is not reached in the baseline scenario. Based on assumed conditions of pumping distribution in the baseline scenario, the maximum withdrawal reduction results in total pumping of 349,395 AFY (9,395 AFY or about 2.8 percent higher than the firm yield).

A comparison of pumping under the previously-adopted CPM rules (EAA, 2006) and the S.B. 3- amended CPM rules (EAA, 2008) is shown on Figure 3-1 for the first half of the model including the drought of record. As shown, the amended rules generally result in smaller pumping volumes during critical periods than would have occurred under previous CPM rules. This occurs because previous CPM rules contained less restrictive triggers and smaller percent reductions associated with each of the CPM stages. Conversely, during non-critical periods, larger pumping volumes occur under the amended rules than under the previous rules. This is due to the larger pumping cap of 572,000 AFY under the amended rules. Note that this amended pumping cap is not reached on an annualized basis during the first half of the model period (Figure 3-1). During almost all of the years in the model period of record, CPM pumping reductions are triggered for at least some portion of the

year. Even during wetter conditions of the second half of the model, the maximum annual permitted pumping is achieved in only two years.

3.1.4. RESOLUTION OF DRY CELLS IN THE MODEL

The additional stress of increased pumping in the baseline scenario results in dry cells in the model. A dry cell occurs when simulated water levels fall below the bottom of a model cell. Dry cells can cause numerical instability in the model and prevent the inactive cell from accepting additional recharge or continuing to simulate flow.

While there are numerical methods to re-wet dry cells, the original model did not incorporate re-wetting options and allowed the cells to remain dry through the remainder of the transient simulation. Consequently, the original model simulated a total of 56 dry cells at the end of the first half of the model (including the drought of record), reducing recharge somewhat during that time period. Although the cause for those dry cells is not entirely clear, the lack of recharge was accounted for in the calibration of the model for water levels and springflow at key targets (J-17, Comal Springs, and other targets). The location of these dry cells indicates potential model inaccuracies in the recharge zone including aquifer parameters such as storativity values. The number and location of the dry cells were considered acceptable given the overall objectives of the original model. These inaccuracies are discussed in more detail in the model documentation (Lindgren, et al., 2004).

Increasing pumping for baseline conditions exacerbates the dry cell problem, especially during the drought of record, to a point where a reasonable numerical solution is not possible. Possible causes of the problem could be numerical error and/or over-stressing the northern constant flux boundary from increased pumping. Because the R&R scenarios involve enhanced recharge (with higher water levels), subsequent model runs did not encounter dry cell issues as significant as baseline conditions. Nonetheless, in order to maintain the integrity of the original mass balance in the MODFLOW model, the circumstances were judged sufficiently sensitive to require resolution prior to proceeding with the baseline scenario.

To resolve the dry cell issue, two solutions were evaluated. One possible solution was to allow dry cells to be “re-wet.” This is a numerical solution that does not prevent a cell from going dry, but simply allows the cell subsequently to be re-wet with additional recharge. MODFLOW 2000 (Harbaugh, et al., 2000) includes a re-wetting option that allows dry cells to become “wet” if water levels in surrounding cells reach a certain level, but remain dry if surrounding cells do not meet the re-wetting criteria. Because different model inputs result in different cells remaining dry, changes to recharge could vary with each model run. In addition, this package sometimes causes numerical instability due to the iterative nature of the solution.

The second solution to the dry cell issue was the incorporation of a new solver developed by Southwest Research Institute (SWRI), referred to as the NR solver. The NR solver was provided to Todd Engineers by EAA staff and was tested during the development of the baseline scenario. The model water balance output using the NR solver was determined to produce results almost identical to model output with the MODFLOW re-wetting package. As such, the NR solver was determined to be unnecessary for the simulation of baseline conditions. Additional simulations in the study were monitored for potential dry cell and model instability in case the NR solver was determined to be needed.

Notwithstanding these issues, the MODFLOW re-wetting package produced successful results in the Phase III study. Significant numerical instability was not observed, and dry cells were re-wet according to program criteria. A check of the model mass balance indicated similar but slightly higher recharge amounts in the baseline scenario when compared to the original model. Differences were small and judged to be insignificant. For all model runs, recharge input and output were compared to ensure no significant difference (≥ 5 percent).

3.1.5. REPRESENTATIVE HYDROLOGIC CONDITIONS

In order to compare baseline and R&R scenarios under various hydrologic conditions, time periods representative of various recharge amounts were selected. Recharge to the aquifer is mainly a result of precipitation and runoff occurring over the recharge zone. Precipitation and recharge vary seasonally and over time, affecting water levels and springflow. Figure 3-2 shows the annual recharge from 1947 to 2000 as simulated in the original EAA model. Over that time period, the amount of annual recharge to the aquifer has ranged from about 44,000 AFY in 1956 to 2,490,000 AFY in 1992 (Figure 3-2).

The recharge record was examined for time periods representative of dry, wet, and average baseline conditions for further evaluation of R&R scenarios. Multi-year periods or “cycles” were selected that contain recharge amounts that were overall lower, higher, and equivalent to an average annual recharge of about 709,000 AFY, the average for the model period of record. Some variability within a cycle was needed to check appropriate aquifer response to varying recharge amounts. For example, the cycle representative of wet conditions would be expected to contain one or more dry years and dry conditions could contain one or more wet years. Cycles of approximately eight to ten years were judged sufficient in length to represent hydrologic conditions. An additional consideration provided that the entire cycle was contained in either the first half (1947-1973) or the second half of the model (1974-2000) since model runs are conducted on each half separately.

Although numerous time periods met the criteria, three recharge periods were selected as representative of these hydrologic conditions. The periods are identified on Figure 3-2 by

color with dry, average, and wet baseline conditions colored red, yellow, and green, respectively. These cycles are summarized in Table 3-3.

Table 3-3: Representative Hydrologic Conditions

Hydrologic Condition	Time Period	Average Annual Recharge (AFY)	Percent of Long-Term Average
Dry Conditions	1947 - 1956	274,966	37%
Average Conditions	1976 - 1983	814,676	109%
Wet Conditions	1986 - 1993	1,080,854	144%

Dry conditions are contained within the first half of the model and represent the drought of record for the entire model period. Region L planning criteria require examination of water management strategies during the drought of record, defined in previous planning documents as the period 1947-1956. The baseline scenario for dry conditions incorporates the limited amount of recharge that occurred during that period and also includes increased pumping as described above. The time period selected for average and wet conditions are contained in the second half of the model.

These representative hydrologic conditions are also contained within the time period covered by the WAM, which was used to generate estimates of streamflow that could potentially be available for recharge. To ensure that the amounts of streamflow identified in the WAM modeling was consistent with the baseline conditions simulated with the groundwater model, modifications were made to the existing WAM. These modifications involved using springflow output generated from the EAA model for the baseline scenario as input into the WAM. Springflow is incorporated into the WAM as additional surface water available for downstream water rights. These modifications are described in more detail in Chapter 5 on surface water modeling.

The identification of these hydrologic cycles is provided as required by the Scope of Work. However, results of the management strategies analyzed in this study are typically presented over two longer time periods: 1947-1973 and 1974-2000. These two periods represent the two halves of the transient portion of the EAA model. The longer periods allow for observation in how preceding hydrologic conditions impact current conditions and contain more variability over time than shorter cycles. As previously explained, the first half of the model, including the drought of record, contains overall dry conditions and the second half contains average to wet conditions. In addition to these longer-term cycles, specific water available during the drought of record (1947-1956) is analyzed separately to comply with Region L requirements.

3.2. RESULTS OF BASELINE SCENARIO

The results of the baseline scenario are documented through model output of springflow at key springs (Figure 3-3) and water levels at index wells J-17 (San Antonio Pool) and J-27 (Uvalde Pool) (Figure 3-4). Trigger levels for CPM stages are shown on the scales for reference and various critical period stages are shaded on the graph according to triggers associated with the respective spring or well. For the San Antonio Pool, critical period stages are triggered by either of the three trigger locations (Comal Springs, San Marcos Springs, and Index Well J-17). For the Uvalde Pool, critical period stages are triggered only by Index Well J-27.

As shown on the Figure 3-3, Comal Springs flow is below 225 cfs, trigger for Stage 1, for most of the period of record. Subsequent CPM stages are also triggered at flow rates of 200 cfs (Stage II), 150 cfs (Stage III), and 100 cfs (Stage IV). As shown on Figure 3-3, the Stage IV critical period is in effect for almost the entire 7 year period from 1951 through 1957. Comal Springs flow during average hydrologic conditions (1976-1983) ranges between 150 cfs and about 300 cfs. Springflow during wet conditions (1986-1993) is highly variable and ranges up to more than 400 cfs (Figure 3-3). Critical periods are triggered in both average conditions and wet conditions with Stage III flows being reached in both cycles.

A comparison of Comal Springs with San Marcos Springs illustrates the importance of Comal Springs as the main trigger for critical periods. Under the baseline conditions, Comal Springs flow reaches critical period stages well before San Marcos springflow.

Figure 3-4 shows simulated water levels at index wells J-17 and J-27 for the baseline scenario. Also shown on the figure are the trigger levels for critical period stages, similar to those shown on Figure 3-3. Similar to Comal Springs, J-17 levels trigger CPM withdrawal reductions during most of the baseline scenario. During dry conditions, Stages III and IV are in effect. During average and wet conditions, both non-critical periods and critical periods (up to Stage III) are in effect. Baseline results for the Uvalde Pool, as indicated by Index Well J-27, show Stage IV conditions for the 1950s and 1960s. However, after about 1975, the Uvalde Pool is out of critical period.

Illustration 3-3 below shows a comparison of springflow between the baseline scenario and the original calibrated MODFLOW model for the relatively dry conditions of the first half of the model time period. This time period is shown to provide a detailed view of the drought of record (1947-1956).

Illustration 3-3: Comal Springflow from Unmodified EAA Model and Baseline Conditions

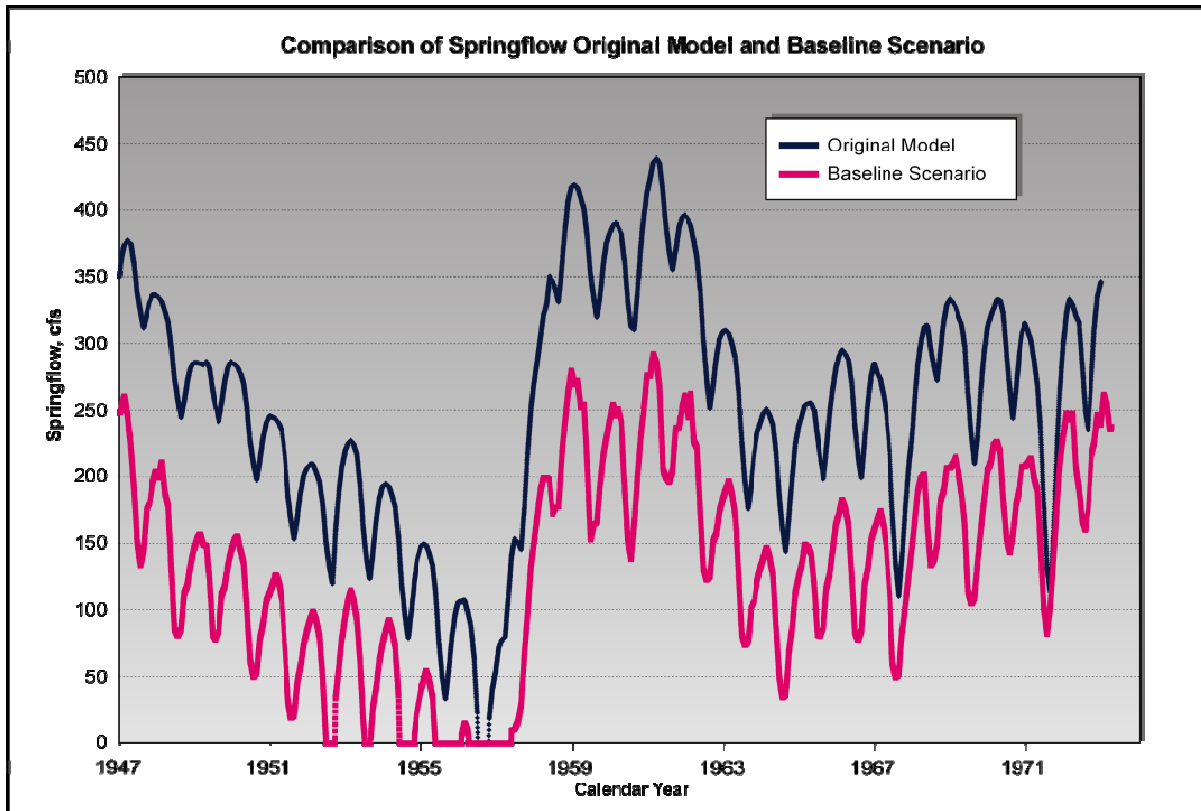

The figure shows good correlation in springflow patterns, with baseline springflow typically about 100 to 150 cfs lower than the original model springflow. As shown, the baseline springflow is in critical period stages (below 225 cfs) for most of the time period and only rarely exceeds 250 cfs. The baseline scenario also indicates relatively long periods of Stage IV flows (below 100 cfs) and periods of no flow at Comal Springs.

4. PRELIMINARY GROUNDWATER MODEL RUNS

The first step in identifying operational parameters for an R&R program was to evaluate the aquifer response to enhanced recharge for different locations, volumes, and timing. Although similar analyses had been conducted in Phase II, additional model runs were required to incorporate new baseline conditions. The locations examined in these runs are Type 2 recharge sites as shown on Figure 1-1 and listed from west to east below:

- Indian Creek (IC)
- Lower Frio (LF)
- Lower Sabinal (LS)
- Seco Creek (SC)
- Lower Hondo (LH)
- Lower Verde (LV)
- San Geronimo (SG)
- Cibolo (C)
- Lower Blanco (LB)

Simulations of one-time (slug) recharge at the beginning of each model half (dry and average conditions) and annual recharge applied seasonally each year were evaluated. The water budget for each model simulation was compared to the baseline scenario water budget. The difference in recharge, pumping, and spring discharge (volume and rate) between the enhanced recharge run and baseline was calculated for each run using MODFLOW mass balance results. Additionally, the changes in water levels for index wells J-17 and J-27 and the impact on the CPM stages were also examined. The water budget comparison indicates the fate of the recharged water and the amount stored in the aquifer over time. Although the input pumping was not increased over baseline, pumping usually increased during the simulation. This occurs because increased water levels allow more pumping due to less severe CPM stages. An increase in pumping and springflow over baseline conditions is defined as the total yield for the enhanced recharge run.

4.1. EVALUATION OF ENHANCED RECHARGE AT TYPE 2 SITES

Numerous runs were performed to examine the same enhanced recharge applied at individual Type 2 recharge sites to compare their relative performance. The runs included both one-time recharge events applied at the beginning of the model time period (referred to herein as slug recharge) and more continuous recharge applied over the course of the model time period (referred to herein as annual recharge). Each run was simulated in both the first half of the model (1947-1973) and the second half of the model (1974-2000). The first half of the model simulates a relatively drier period, including the drought of record. The second half of the model is characterized by average and wet conditions.

4.1.1. EVALUATION OF ONE TIME (SLUG) RECHARGE AT TYPE 2 SITES

For the slug recharge runs, 5,000 AF of enhanced recharge was applied over five months (March through July), for a total of 25,000 AF for the first year of each model half. This seasonal recharge was selected to simulate additional recharge water available in times of increased precipitation. Additional runs were performed with a constant recharge of 2,083.33 AF/month over the entire year to compare to seasonal recharge only. Differences between seasonal recharge and annual recharge runs were minor and seasonal recharge was selected for all slug recharge scenarios. Two independent slug recharge events were simulated per recharge location. One slug recharge occurred in 1947 (the beginning of the first half of the model) and one occurred in 1974 (the beginning of the second half of the model). The two halves of the model were treated independently; the initial conditions for the beginning of the second half of the model were kept identical to the baseline model.

Overall, the enhanced recharge results in increased yield in both springflow and pumping (by reducing time in CPM stages). In addition, at the end of the model run, some recharge water remains in aquifer storage. The differences between the baseline water budget and the enhanced recharge scenarios budgets were calculated at the last stress period for each half of the model (December 1973 or December 2000 for the first and second halves of model, respectively). A summary of the effects on various water budget items for the 1947 and 1974 slug recharge events at each location is shown graphically on Figure 4-1.

As shown on the figure, the fate of approximately 25,000 AF of recharge is distributed among four water budget elements. The total volume of increased pumping due to less severe CPM reductions is shown in blue, the increased volumes of springflow to Comal Springs and other springs are shown in green and gray respectively, and the volume of recharge remaining in aquifer storage at the end of the simulation is shown in light blue. Actual volumes shown graphically on Figure 4-1 are tabulated for each of the two model halves in Tables 4-1 and 4-2 below.

Table 4-1: Results of Slug Recharge 1947-1973

Results of 25,000 AF Slug Recharge 1947 - 1973 (AF)										
	Indian Creek	Lower Frio	Lower Sabinal	Seco Creek	Lower Hondo	Lower Verde	San Geron.	Cibolo Dam	Lower Blanco	Average
Remaining in Aquifer	7,522	4,493	1,730	631	751	3,081	357	-93	766	2,160
Pumping	9,418	13,802	14,756	17,345	15,260	13,145	18,727	8,944	0	12,378
Other Springs	1,594	1,992	1,379	826	829	883	-401	8,460	22,940	3,638
Comal Springs	5,799	4,602	7,004	5,672	7,254	8,304	6,166	7,050	1,295	6,545
Total Recharge Distributed*	24,332	24,889	24,869	24,474	24,095	25,413	24,848	24,361	25,001	24,720

**Note: total recharge varies slightly from the 25,000 AF total due to unit conversions and rounding in the groundwater model*

Table 4-2: Results of Slug Recharge 1974-2000

Results of 25,000 AF Slug Recharge 1973 - 2000 (AF)										
	Indian Creek	Lower Frio	Lower Sabinal	Seco Creek	Lower Hondo	Lower Verde	San Geron.	Cibolo Dam	Lower Blanco	Average
Remaining in Aquifer	5,236	3,307	1,466	1,074	1,278	1,290	2,029	352	533	1,841
Pumping	2,719	8,573	12,704	12,077	12,077	9,214	12,370	11,091	0	8,980
Other Springs	11,540	10,258	5,454	5,485	5,031	5,308	1,975	7,981	23,873	8,545
Comal Springs	5,758	3,114	5,628	6,616	6,868	9,440	8,878	5,829	847	5,886
Total Recharge Distributed*	25,253	25,253	25,253	25,253	25,253	25,253	25,253	25,253	25,253	25,253

**Note: total recharge varies slightly from the 25,000 AF total due to unit conversions and rounding in the groundwater model*

As shown by the dark blue portion of the bar graph and values in the tables above, increases to pumping were more significant for almost all locations in the first half of the model (average 12,378 AF) than in the second half of the model (8,980 AF). The slug recharge decreased the time or severity of these critical period stages, which was more prevalent in the dry conditions of the first model half. During the second half of the model, CPM reductions were much less and, as a result, more of the recharge water was discharged to springs, especially to springs other than Comal Springs. The 1974 enhanced slug recharge resulted in more outflow from Comal Springs and other springs (an average

of 14,431 AF, an increase of 42 percent over the 1947 slug recharge, 10,183 AF). Contribution to other springs was primarily from Indian Creek and Lower Blanco, the two locations on the western and eastern ends of the study area, respectively. Some of the Indian Creek recharge is discharged at Leona Springs in southern Uvalde County and most of Lower Blanco recharge is discharged to San Marcos Springs in southern Hays County (Figure 1-1).

Comal Springs benefited from recharge at all sites, with most sites contributing about 25 percent to 33 percent of total recharge to the springs. Lower Blanco contributed the least, especially during the second model half, given its downgradient location. The higher water levels from the 1974 slug and greater springflow resulted in less water remaining in storage than the 1947 slug recharge event. In both runs, the recharge added at the western sites, Indian Creek and Lower Frio, resulted in more water remaining in aquifer storage.

The sites in the central part of the study area (Lower Sabinal, Lower Hondo, Seco Creek, Lower Verde, and San Geronimo) behaved similarly to one another in both model runs. For the 1947 slug run, recharge at the five central locations resulted in an average yield of:

- 28 percent of recharge contributing to Comal Springs,
- 3 percent of recharge to other springs,
- 64 percent of recharge to additional pumping, and
- 5 percent of recharge remaining in the aquifer.

Under the 1974 slug recharge run, these central locations also behaved similarly to each other with more water discharged to springflow as pumping demand was satisfied. The 1974 slug run resulted in an average yield of:

- 30 percent of recharge in additional springflow from Comal Springs,
- 18 percent of recharge to additional springflow from the other springs,
- 46 percent of recharge to additional pumping, and
- 6 percent of recharge remaining in the aquifer.

The length of time that enhanced recharge remains in the aquifer (referred to herein as retention time) depends on the timing and location of the slug recharge. The two graphs on Figure 4-2 show the change in retention time for recharge slugs in 1947 and 1974.

The retention time curves indicate the length of time that the recharged water remains in aquifer storage before being discharged from the system by pumping or springflow. In general, retention times for slug recharge sites decrease from west to east with western sites contributing more to long-term storage. At eastern sites, recharged water is discharged quickly as springflow. As shown on Figure 4-2, all curves contain abrupt jumps during certain time periods. This is due to short-term changes in pumping as triggered by the critical period stages. For example, the 1947 slug in Lower Verde allows a critical period stage to be avoided in April 1960, resulting in an increase of pumping of 6,600 AF

over baseline. In turn, this increased pumping results in lower water levels that again trigger a more severe critical period stage in July 1960, resulting in a decrease of pumping of 2,700 AF.

Tables 4-3 and 4-4 summarize the retention times for both slug recharge events. The table presents the amount of time (in years) that a certain percent of the enhanced recharge remains in aquifer storage. For illustration, retention times for eighty percent, fifty percent, and twenty percent of enhanced recharge are shown.

Table 4-3: Aquifer Retention Time for 1947 Slug Recharge

Percent of Recharge	Time in Aquifer (Years)								
	Indian Creek	Lower Frio	Lower Sabinal	Seco Creek	Lower Hondo	Lower Verde	San Geronimo	Cibolo	Lower Blanco
80%	2.5	1.8	0.8	0.9	1.2	1.9	0.6	0.7	0.0
50%	13.4	3.8	2.0	1.8	2.5	3.6	1.1	1.1	0.7
20%	>27	26.3	4.8	3.6	5.3	11.6	3.0	2.8	1.0

Table 4-4: Aquifer Retention Time for 1974 Slug Recharge

Percent of Recharge	Time in Aquifer (Years)								
	Indian Creek	Lower Frio	Lower Sabinal	Seco Creek	Lower Hondo	Lower Verde	San Geronimo	Cibolo	Lower Blanco
80%	3.9	1.8	0.8	0.9	0.9	1.6	0.7	0.7	0.0
50%	10.7	5.8	1.9	1.6	2.5	4.0	0.8	1.4	0.7
20%	>27	18.2	7.0	6.6	7.1	9.1	3.7	1.6	1.0

As shown on Tables 4-3 and 4-4, retention times decrease from west (Indian Creek) to east (Lower Blanco), with a major change occurring between Lower Verde and San Geronimo. For sites west of San Geronimo, about 80 percent of the water recharged is still in the aquifer about 1 year or more after recharge, whereas it is discharged more quickly in the three eastern sites. The difference is even more pronounced for the 50 percent and 20 percent retention times. As shown on Table 4-4, retention times are longer during wet and average conditions (second half of the model period). For example, about 80 percent of the water recharged at Indian Creek is still in storage after almost 4 years while an equivalent amount from Lower Blanco is discharged in less than 0.1 year (rounded to 0.0 on the table). For most of the central and western sites, at least one-half of the recharged water is still in

aquifer storage after 2 years under both slug recharge time periods. Although there is variability between the two model runs, aquifer recharge allocation is similar between sites.

4.1.2. EVALUATION OF ANNUAL RECHARGE AT TYPE 2 SITES

A similar analysis to the slug recharge modeling was conducted using annual recharge over the model simulation. Recharge was applied seasonally (March through July) every year for the first half of the model (1947-1973) and the second half of the model (1974-2000). As with the slug recharge, the two halves were treated as individual models; the starting heads of the second half of the model were the same as in the baseline simulation. The annual recharge water budgets were compared to the baseline water budget, and the changes in outflow were used to determine the yield of enhanced recharge at the end of each model half (December 1973 or December 2000).

The two graphs on Figure 4-3 show the results of annual recharge of 25,000 AFY, for each model half. Tables 4-5 and 4-6 tabulate the results. Overall, the relative behavior of each location is similar for both model runs.

Table 4-5. Results of Enhanced Annual Recharge 1947-1973

Results of 25,000 AFY Recharge 1947 - 1973 (AF)									
	Indian Creek	Lower Frio	Lower Sabinal	Seco Creek	Lower Hondo	Lower Verde	San Geron.	Cibolo Dam	Lower Blanco
Remaining in Aquifer	330,302	229,195	126,483	119,650	123,314	143,556	75,428	49,694	10,493
Pumping	218,078	286,086	264,091	272,144	262,591	254,311	270,596	149,741	3,948
Other Springs	25,216	27,783	30,201	29,251	28,557	26,740	28,269	229,514	634,856
Comal Springs	94,525	125,015	247,052	254,130	254,227	244,170	292,306	238,694	18,391
Total Recharge Distributed*	668,121	668,079	667,828	675,174	668,688	668,777	666,599	667,643	667,688

**Total recharge varies slightly from total applied due to unit conversion and rounding in groundwater model*

Table 4-6. Results of Enhanced Annual Recharge 25,000 AFY 1974-2000

Results of 25,000 AFY Recharge 1974 - 2000 (AF)									
	Indian Creek	Lower Frio	Lower Sabinal	Seco Creek	Lower Hondo	Lower Verde	San Geron.	Cibolo Dam	Lower Blanco
Remaining in Aquifer	313,242	220,860	108,519	102,056	104,994	125,203	61,649	49,687	9,227
Pumping	91,149	131,964	253,161	259,884	275,502	263,223	317,434	158,591	11,855
Other Springs	208,254	226,417	133,036	123,492	110,384	100,895	72,508	230,273	639,713
Comal Springs	62,286	95,690	180,215	189,499	184,050	185,610	223,340	236,380	14,135
Total Recharge Distributed*	674,931	674,931	674,931	674,931	674,931	674,931	674,931	674,931	674,931

**Total recharge varies slightly from total applied due to unit conversion and rounding in groundwater model*

A comparison of the two tables indicates significant changes between the conditions for the first and second halves of the model. For the drier time period 1947-1973, recharge contributes more to Comal Springs and pumping than in the second half of the model. As annual recharge raises water levels, pumping demand is satisfied and increases in pumping are not as high during 1974-2000. This is especially true for the Uvalde Pool (indicated by increases in pumping for the Indian Creek analysis), which remains out of critical periods for the second half of the model. In addition, as water levels rise in the second half of the model, other springs including San Pedro and San Antonio begin to flow, contributing a significant portion of the recharge water to other springs.

These observations are more readily observed on Tables 4-7 and 4-8, where the results of the model runs are presented as a percent of the total recharge applied. This presentation allows for a quick survey of the contribution that recharge has on springflow, pumping, and aquifer storage for each of the two time periods.

Table 4-7. Results of 25,000 AFY Enhanced Recharge as Percent Applied (1946-1973)

Recharge Site	Indian Creek	Lower Frio	Lower Sabinal	Seco Creek	Lower Hondo	Lower Verde	San Geron.	Cibolo Dam	Lower Blanco
Remaining in Aquifer	49%	34%	19%	18%	18%	21%	11%	7%	2%
Pumping	33%	43%	40%	40%	39%	38%	41%	22%	1%
Other Springs	4%	4%	5%	4%	4%	4%	4%	34%	95%
Comal Springs	14%	19%	37%	38%	38%	37%	44%	36%	3%

Percentages may not total 100% due to rounding.

Table 4-8. Results of 25,000 AFY Enhanced Recharge as Percent Applied (1974-2000)

Recharge Site	Indian Creek	Lower Frio	Lower Sabinal	Seco Creek	Lower Hondo	Lower Verde	San Geron.	Cibolo Dam	Lower Blanco
Remaining in Aquifer	46%	33%	16%	15%	16%	19%	9%	7%	1%
Pumping	14%	20%	38%	39%	41%	39%	47%	23%	2%
Other Springs	31%	34%	20%	18%	16%	15%	11%	34%	95%
Comal Springs	9%	14%	27%	28%	27%	28%	33%	35%	2%

Percentages may not total 100% due to rounding.

Similar to the analysis for slug recharge, retention curves were generated for the model runs with 25,000 AFY annual recharge. Figure 4-4 shows the length of time (in years) that the enhanced recharge remains in aquifer storage. The stair-step nature of the curves reflects the seasonal recharge, subsequent decline, and additional recharge. That is, recharge occurs at a faster rate than storage declines. The retention curves exhibit similar relationships between recharge sites as seen on the slug recharge retention curves. These data are tabulated on Tables 4-9 and 4-10 to illustrate the number of years after which 80 percent, 50 percent, and 20 percent of the total recharged water still remains in aquifer storage.

Table 4-9: Aquifer Retention Time for 25,000 AFY Recharge 1947-1973

Percent of Recharge	Time in Aquifer (Years)								
	Indian Creek	Lower Frio	Lower Sabinal	Seco Creek	Lower Hondo	Lower Verde	San Geron.	Cibolo	Lower Blanco
80%	7.17	3.00	0.92	1.00	1.25	2.33	1.00	0.67	0.00
50%	23.08	14.08	3.83	3.92	5.08	7.17	3.92	2.08	0.75
20%	>27	>27	21.92	19.25	21.92	22.25	19.25	11.08	1.00

Table 4-10: Aquifer Retention Time for 25,000 AFY Recharge 1974-2000

Percent of Recharge	Time in Aquifer (Years)								
	Indian Creek	Lower Frio	Lower Sabinal	Seco Creek	Lower Hondo	Lower Verde	San Geron.	Cibolo	Lower Blanco
80%	8.0	2.9	0.8	0.8	0.9	2.0	0.8	0.6	0.0
50%	22.9	12.8	3.7	3.8	4.8	6.8	1.8	1.8	0.7
20%	>27	>27	20.7	19.7	20.7	25.8	9.7	9.7	1.8

As shown above, the west to east relationship of retention times are similar to those observed for the slug recharge, with water recharged at western and central sites contributing more to long-term storage. For the 25,000 AFY annual recharge, there are fewer differences observed in retention times from the first model period (Table 4-9) to the second (Table 4-10) than in the slug recharge (Tables 4-3 and 4-4). As water accumulates in storage over time, there are fewer impacts from CPM rules and the natural system re-equilibrates.

4.2. EVALUATION OF MINIMUM SPRINGFLOW

Several recharge scenarios were simulated at each recharge location in order to determine the amount of enhanced recharge that would be required to maintain minimum springflow at Comal Springs during the drought of record. The analysis examined two different minimum springflows, 40 cfs and 150 cfs, as required by the Phase III/IV scope of work (Appendix A). Minimum springflow was examined under dry conditions (1947-1956) contained within the first half of the model and average conditions (1976-1983) contained within the second half of the model. Table 4-11 shows the annual enhanced recharge needed at each location to meet the minimum springflow requirements during dry and average conditions. The analysis is described in the following sections.

Table 4-11. Annual Enhanced Recharge to Maintain Comal Springs Flow for Dry and Average Conditions

Type 2 Recharge Site	Dry Conditions (1947-1956) (AFY)		Average Conditions (1976-1983) (AFY)	
	40 cfs	150 cfs	40 cfs	150 cfs
Indian Creek	575,000	1,850,000	-	150,000
Lower Frio	400,000	750,000	-	80,000
Lower Sabinal	150,000	325,000	-	33,000
Seco Creek	155,000	315,000	-	35,000
Lower Hondo	160,000	325,000	-	35,000
Lower Verde	165,000	350,000	-	40,000
San Geronimo	117,000	260,000	-	25,000
Cibolo	160,000	340,000	-	27,000
Lower Blanco	5,000,000	> 10,000,000	-	300,000

4.2.1. MINIMUM SPRINGFLOW DURING DRY CONDITIONS

As shown for the dry conditions in Table 4-11, significant volumes of enhanced recharge are required if any one site is designated for springflow maintenance alone. Maintaining 40 cfs under dry conditions required annual recharge from 117,000 AFY to 5,000,000 AFY. Western sites (Indian Creek and Lower Frio) are less effective due to the distance from Comal Springs. About 160,000 AFY is required for any of the central sites during dry conditions. The eastern site, Lower Blanco, is the least effective for springflow maintenance at Comal Springs because of its downgradient location and quick discharge at San Marcos Springs. At most sites, maintaining springflow at 150 cfs requires more than twice the recharge needed for 40 cfs during dry conditions.

A comparison of 40 cfs and 150 cfs requirements (dry conditions) in Table 4-11 above confirms that more enhanced recharge is needed to maintain Comal Springs at a higher minimum flow, but the relationship is nonlinear. In most cases, the recharge needed to meet the higher minimum springflow resulted in greater flows from springs other than Comal Springs.

The fate of the total enhanced recharge water at each location under dry conditions is illustrated on Figures 4-5 and 4-6, for the 40 cfs and 150 cfs requirements, respectively. Note that the total recharge amount on the figures reflects the application of the annual recharge in Table 4-11 applied in every year of the first half model period. In reality, these

amounts could be substantially reduced in most years and increased mainly in drier years if source water for enhanced recharge were available. Nonetheless, the relative distribution and magnitude of the fate of the recharge water provides useful guidance for the amounts of recharge needed for springflow maintenance.

Because all of the recharge water does not contribute to springflow, a recharge amount larger than the difference in springflow between baseline and minimum levels is required. The two western locations (Indian Creek and Lower Frio) as well as the eastern location (Lower Blanco) require larger amounts of annual recharge because so little of the recharged amount contributes to Comal Springs flow. At these sites, a larger percentage of water contributes to other springs including Leona Springs in the west and San Marcos Springs in the east. In the central locations (Lower Sabinal, Seco Creek, Lower Hondo, Lower Verde, and San Geronimo), enhanced recharge increases the amount of water that can be pumped (by reducing CPM stages), so some recharge is discharged through pumping before springflow benefits can occur. However, the central locations require less recharge than the far western or eastern locations.

4.2.2. MINIMUM SPRINGFLOW DURING AVERAGE CONDITIONS

As shown for the average conditions in Table 4-11, the amount of enhanced recharge required to maintain minimum flows decreases substantially under average hydrologic conditions. In the baseline scenario, the lowest springflow under average hydrologic conditions (1976-1983) was 141 cfs; therefore, no enhanced recharge is required to meet the 40 cfs minimum springflow requirements. For maintaining springflow at 150 cfs, a range of 25,000 AFY to 300,000 AFY is required for the respective recharge sites. San Geronimo and Cibolo sites appear to be the most effective for springflow maintenance.

Figure 4-7 shows the fate of the total amount of enhanced recharge at the rate required for a minimum of 150 cfs under average hydrologic conditions. Note that the total recharge amount on the figure reflects the application of the recharge in Table 4-11 in every year of the second half model period. In reality, these amounts could be substantially reduced in most years and increased mainly in drier years if source water for enhanced recharge were available. Nonetheless, the relative distribution and magnitude of the fate of the recharge water provides useful guidance for the amounts of recharge needed for springflow maintenance. The locations that required a smaller amount of annual recharge also have a higher percent of the enhanced recharge flowing out of the Comal Springs as shown by the green portion of the bars on Figure 4-7. As seen in previous model runs, the Lower Blanco site is least effective for maintenance at Comal Springs since most of the recharge affects San Marcos Springs.

5. SOURCE WATER AVAILABILITY

Since R&R strategies depend on both the sources and amounts of water available for recharge enhancement, potential sources of water were analyzed in this Phase III/IV study. Both surface water and groundwater sources were identified and quantified over time. Additional surface water may be available from unappropriated water in streams that cross the recharge zone. Surface water may also be available at various locations along the Guadalupe River for transmittal to the recharge zone via pipeline. In all cases, existing water rights, environmental needs, and other downstream uses must be considered. To quantify available water from these sources while protecting other interests, TRC/Brandes conducted surface water modeling using the TCEQ Water Availability Model (WAM), the tool required for surface water permitting. Application of the WAM and results of surface water modeling are described in this chapter. Figure 5-1 identifies the potential R&R sites evaluated with the WAM. Although the TCEQ developed the WAM, the tool may not incorporate the historic yield of the Nueces River Basin in a way designated by the EAA Act (Texas State Legislature, 1993, Section 1.45b).

Groundwater can also provide a source of recharge by pumping from new or existing wells and recirculating the water back to the recharge zone. Although this concept at first may seem redundant, modeling has shown some long-term benefits for capturing groundwater that would otherwise be discharged and relocating it to certain recharge sites.

Recognizing that a program of consistent and long-term enhanced recharge will likely increase spring discharge, this recharge-induced springflow may also be available for recirculation back to the aquifer. This source, referred to previously by others as excess springflow, represents another potential R&R strategy that could provide recharge benefits. The amount of water available from these sources and methods used for the estimations are provided below.

5.1. SURFACE WATER

The supply of surface water available for use as source water for R&R strategies is dependent upon location and the degree to which the existing surface water system is already appropriated and being used. The TCEQ has developed water availability models (WAM) for all river and coastal basins in Texas, including the GSA and the Nueces river basins that encompass the recharge zone of the Edwards Aquifer. In this study, both the GSA WAM⁴ (as modified and updated by TCEQ) and the Nueces WAM⁵ (also as modified

⁴ HDR Engineering, Inc.; "Water Availability in the Guadalupe-San Antonio River Basin"; prepared for Texas Natural Resource Conservation Commission: December, 1999; Austin, Texas.

⁵ HDR Engineering, Inc.; "Water Availability in the Nueces River Basin"; prepared for Texas Natural Resource Conservation Commission: October, 1999; Austin, Texas.

and updated by TCEQ) have been operated to estimate the available quantities of surface water at specific locations where streamflows may be diverted for R&R purposes.

The GSA and Nueces WAMs utilize the same software for performing water availability analyses. The Water Rights Analysis Program (WRAP), which was developed at Texas A&M University, is specifically structured for determining surface water availability for individual water rights within a river basin, as well as unappropriated water (water that is not appropriated and available for permitting) at designated stream locations. The WRAP software was adopted by the TCEQ for developing each of the WAMs for all of the basins across the state.

Applications of WRAP to the GSA and Nueces basins utilize monthly time steps to simulate water availability over specified periods of years subject to actual monthly historical hydrologic and climatic variations. For the GSA WAM, this period extends from 1934 through 1989. The simulation period used in the Nueces WAM extends from 1934 through 1996. The hydrologic inputs to the models are based on streamflow gage records that have been adjusted to represent naturalized watershed conditions without the influence of man's activities with respect to surface water usage and reservoir operations. Features of individual water rights including maximum annual diversion amounts, maximum diversion rates, water use patterns, return flow patterns, reservoir storage capacities, and various special conditions such as streamflow restrictions are described at control points that are located and connected in the models in accordance with the natural stream network.

During each time step of the WAM simulations, calculations of available water are performed for the individual water rights in order of priority. In the GSA and Nueces basins, water right priorities are based on the prior appropriation doctrine which stipulates that during periods of streamflow shortage the water right with the oldest priority date⁶ is to be allocated water before water rights with more junior priority dates. In the WAMs, the available streamflow at a particular location is fully allocated to the extent of authorized diversions and reservoir storage located at or upstream of the point. The basic output from the WAMs includes monthly time series of the following parameters:

- Diversions by Individual Water Rights
- Return Flows Associated with Diversions
- End-of-Month Reservoir Storage
- Releases from Reservoir Storage
- Evaporation Losses from Reservoirs
- Regulated Flows at Control Points
- Unappropriated Water at Control Points

⁶ The priority date generally is associated with the date when a particular water right was recognized and issued by the State of Texas.

Regulated flows as simulated with the WAMs represent the actual monthly streamflow that would be expected to occur at a particular location on a stream after all water right activities have occurred. Unappropriated water refers to that portion of the regulated flow at a particular location on a stream that is not committed to any water right activity and, therefore, is available for appropriation under a new water right permit. It is this unappropriated water that is of particular interest because this is water that is potentially available, following acquisition of the necessary water rights, for use as source water for new R&R projects for the Edwards Aquifer.

With regard to the GSA WAM, it should be noted that all consumptive and non-consumptive water rights in the basin are individually simulated. In particular, the non-consumptive hydropower rights owned by the Guadalupe-Blanco River Authority (GBRA) along the lower segment of the Guadalupe River are subordinated to Canyon Lake as authorized by the 2001 Amendment of Certificate of Adjudication No. 18-2074E. All of the specific provisions of that amendment are not precisely represented in the TCEQ's version of the GSA WAM; however, the manner in which the basic requirements of the amendment are described in the WAM appears to fully accomplish the intent of the subordination of GBRA's downstream hydropower rights to Canyon Lake.

It is also important to understand that the Nueces WAM represents all water rights in the basin in full compliance with the prior appropriation doctrine, which means that during periods of low streamflow, the available flow at a particular location is allocated to water rights strictly according to priority. In structuring the WAMs, the TCEQ has interpreted this to mean that a reservoir with a senior priority must be completely full before any of the water rights that are junior in priority to that reservoir and are located on streams that flow into that reservoir can divert or impound any streamflow. The significance of this is that all water rights with priority dates junior to those for Lake Corpus Christi (September 15, 1952) and Choke Canyon Reservoir (July 19, 1976) and that are located on watercourses upstream of these reservoirs cannot divert or impound any streamflow until both of these two major downstream reservoirs are full and essentially spilling. Any new appropriation for source water for proposed R&R projects for the Edwards Aquifer that are located on any of the streams that contribute inflows to Lake Corpus Christi or Choke Canyon Reservoir would, of course, be junior in priority to the water rights for these reservoirs and, therefore, would be subject to this limitation. Quantities of unappropriated water determined at a particular location with the Nueces WAM that may be considered as available for R&R certainly reflect this limitation, which essentially guarantees in a legal sense that the available supplies of water for Lake Corpus Christi and Choke Canyon Reservoir are not diminished by any proposed R&R project considered in this study.

5.1.1. APPLICATION AND MODIFICATIONS OF WATER AVAILABILITY MODELS

The primary objective of applying the WAMs in this study has been to provide estimates of the source water supplies that potentially would be available for recharging the Edwards Aquifer at certain stream locations in the Guadalupe and Nueces basins. These potential source water supplies are expressed in terms of “unappropriated” water as defined above and what is referred to as “marketable” water, which is defined as the portion of the appropriated (or permitted) water at a particular location on a stream that has not been used historically and is not anticipated to be needed and used for some period of time in the future, i.e., several years. Estimates of quantities of unappropriated water at specific stream locations can be derived directly from the simulated output from the WAMs, i.e., the GSA WAM and the Nueces WAM; however, only gross and probably somewhat over-stated approximations of the available quantities of marketable water can be ascertained from these models. Development of these data is discussed in later sections of this report.

For this study, the most recent versions of the GSA and Nueces WAMs were obtained directly from the TCEQ in October 2007. As such, these WAMs reflect the updates made by TCEQ with regard to new water rights and water right amendments that had been issued prior to that time. It should be recognized that since that time, there may have been additional appropriations of water authorized in the GSA and Nueces basins that would affect the WAM results presented herein.

The applications of the GSA and Nueces WAMs in this study have required certain modifications in order to provide the necessary inputs for the assessment of the effects of various R&R scenarios on the Edwards Aquifer. In some cases, output from the WAMs had to be reanalyzed to produce the required data. These different modifications and re-analyses are described in the following sections.

SPRINGFLOW ADJUSTMENTS IN GSA WAM

The version of the GSA WAM obtained from the TCEQ at the outset of this study, as well as the current version of this model as presently used by TCEQ, includes spring discharges from the Edwards Aquifer that reflect an assumed maximum annual total pumpage of 400,000 acre-feet from the aquifer and other critical period pumping limitations that the TCEQ considered to be appropriate at the time the original WAM was developed (1999). The spring discharges included in this version of the WAM were simulated by the Texas Water Development Board (TWDB) using the GWSIM4 groundwater model of the Edwards

Aquifer⁷. The technical assumptions and resulting springflows from this simulation are presented in a brief report previously prepared by the TWDB.⁸

The springflows accounted for in the original GSA WAM that reflect the 1999 pumping limitations as simulated by the TWDB include discharges from the following springs (with their associated downstream WAM control points noted in parentheses):⁹

- San Marcos Springs (CP75)
- Hueco Springs (CP04)
- Comal Springs (CP05)
- San Antonio Springs (CP215332)
- San Pedro Springs (CP539101)

Historical quantities of springflows from these springs are embedded in the naturalized streamflows at the individual control points in the WAM. To adjust the naturalized streamflows to account for the effects of the TWDB's simulated groundwater pumping limitations on the historical springflows, monthly adjustment amounts are added to or subtracted from the naturalized streamflow quantities in the WAM. These monthly adjustment amounts as originally derived for purposes of the WAM represent the difference between the monthly historical spring discharges for each of the five springs and the corresponding simulated springflows from the GWSIM4 groundwater model. These monthly adjustments are applied for the entire period of record included in the GSA WAM (January 1934 through December 1989), and they are read into the WAM as part of the input data files.

In order to use the original GSA WAM to generate unappropriated or marketable water that potentially could be available for R&R projects for the Edwards Aquifer under current EAA pumping limitations, it has been necessary to recalculate the springflow adjustment factors to reflect the CPM rules as adopted by the EAA and as recently amended by Article 12 of S.B. 3 (Texas State Legislature, 2007). Pursuant to this study, these rules and pumping limitations have been incorporated into the EAA MODFLOW groundwater model, and this modified model has been operated to simulate a new baseline condition for the historical hydrologic period from 1946 through 2000. Monthly spring discharges from this revised baseline groundwater simulation have been used to recalculate the monthly springflow adjustment factors for the GSA WAM¹⁰ for all of the springs except Hueco Springs. These

⁷ TWDB, "Model Refinement and Applications for the Edwards (Balcones Fault Zone) Aquifer in the San Antonio Region, Texas," Report 340, July 1992.

⁸ TWDB, "Summary of a GWSIM-IV Model Run Simulating the Effects of the Edwards Aquifer Authority Critical Period Management Plan for the Regional Water Planning Process," July 1999.

⁹ It should be noted that the TCEQ water availability model for the Nueces River Basin does not include any specified spring discharges from the Edwards Aquifer.

¹⁰ It should be noted that the revised springflows from the MODFLOW model were available for only the 1946 through 1989 period. For the earlier 1934-1945 period simulated with the WAMs, correlations

springs are not included in the EAA model, so no simulated springflows were available for Hueco Springs with the current CPM rules and pumping limitations in effect. Since the WAM does include monthly discharges from Hueco Springs, a correlation between monthly historical springflows from Hueco Springs and San Pedro Springs was developed and then used to estimate the revised Hueco Springs discharges corresponding to conditions with the current CPM rules and pumping limitations in effect. These estimated springflows for Hueco Springs then were used to recalculate the Hueco monthly springflow adjustment factors for use in the GSA WAM. All of the new revised adjustment factors were incorporated into the data input files for the GSA WAM, thus providing a new baseline WAM that was consistent with the EAA groundwater model used in this study.

METHOD FOR DEVELOPING UNAPPROPRIATED WATER

As noted previously, unappropriated water is one of the primary results produced by the WAMs. For simulating unappropriated water, the version of the WAM for a particular river basin referred to by the TCEQ as “Run 3” must be operated. The Run 3 version of the WAM accounts for all of the existing water rights in a particular basin with these rights exercised at their fully authorized diversion and storage amounts, normally without any return flows associated with the simulated diversions. The Run 3 simulated unappropriated water at a particular location (control point) represents the monthly quantities of streamflow that are available for appropriation (for permitting) based on the WAM’s simulation period (either 1934-1989 for the GSA WAM or 1934-1996 for the Nueces WAM). Following acquisition of proper water right permits from the TCEQ, these are the total quantities of streamflow that potentially could be available for recharging the Edwards Aquifer, provided no restrictions are imposed on the diversion and use of these streamflows as a result of the permitting process.

In this study, the Run 3 versions of the GSA WAM (modified as described in the previous section) and the Nueces WAM have been operated. The time series of the unappropriated water at specified locations on streams within the basins where potential Type 2 recharge facilities may be constructed have been extracted and summarized. These data then have been used in the groundwater modeling as sources of surface water for potential R&R projects.

METHOD FOR DEVELOPING OF MARKETABLE WATER

As previously defined, marketable water is assumed to be that portion of streamflow that occurs at a particular location within a river basin that is appropriated by existing water rights, but not fully utilized under current conditions or conditions that are expected to occur in the foreseeable future, i.e., next several years. With regard to potential R&R

were developed between the revised springflows and historical springflows using the 1945-1989 data, and these correlations were used to estimate the required revised springflows for the 1934-1945 period.

projects, the idea is that such marketable water could be acquired (purchased or leased) from one or more water right owners for a period of time during which the owners would not need the water. This water, again after satisfying the necessary permitting requirements, then could be used as a source of recharge water during that period.

The availability of such marketable water is directly associated with a particular water right or group of water rights and is directly dependent on the extent to which diversions under these rights have been made historically and whether their full authorized appropriation of surface water will be needed and used in the future. To accurately arrive at quantities of marketable water would involve a detailed assessment of each individual water right located both upstream and downstream of every location being considered for potential R&R projects to ascertain whether or not full use of the water right was contemplated by its owner in the foreseeable future and whether or not the owner would be willing to sell or lease any unneeded authorized diversions for use as source water for a new recharge/recirculation project. This process obviously would involve considerable time and effort and was not considered to be appropriate or necessary for the level of analyses being undertaken in this study.

Alternatively, results from the WAMs can be used to provide a gross estimate of the total amount of marketable water that potentially could be available at a particular location within a stream system. For this purpose, the version of the WAMs referred to by the TCEQ as "Run 8" must be employed. This version of the WAM for a given river basin accounts for all of the existing water rights, but only with these water rights exercised to the extent of their actual maximum annual diversion amounts as were reported to have occurred during the last 10 years prior to the time when the WAMs were developed, i.e., generally from the late 1980s to the late 1990s. Any return flows associated with these diversion amounts also are included as discharges in the Run 8 versions of the WAMs.

The difference between the simulated monthly diversions for a particular water right from a WAM Run 8 and that water right's corresponding simulated monthly diversions from the full-authorization WAM Run 3 theoretically represents the monthly quantities of unused and authorized diversions for that water right. This water could be considered as marketable (available for term use) and potentially available as source water for a proposed R&R project for the Edwards Aquifer.

The total amount of water that might be considered marketable at a particular location can be estimated based on the difference between the simulated quantities of unappropriated water from WAM Run 8 and from WAM Run 3. It is important to recognize, however, that this estimate of marketable water at a specific location in a basin represents contributions from all existing water rights located both upstream and downstream, depending on relative priorities among water rights. For this reason, this estimate of marketable water is likely over-stated and in excess of the amount that could actually be made available from existing water rights owners. Still, the values of marketable water derived from the WAMs with this procedure do tend to bracket the available supplies of source water that

potentially could be used for proposed R&R projects and thereby demonstrate whether pursuing the development of such supplies would be warranted.

ENVIRONMENTAL FLOW REQUIREMENTS

The TCEQ, when considering applications for new water rights or even for amending existing water rights involving changes in appropriation, normally requires certain minimum quantities of streamflow to be bypassed for protection of instream uses before water can be diverted or stored. Such flow bypass requirements could be imposed on the water rights supporting an R&R project. The amount of water required to be bypassed typically depends on downstream environmental conditions and the extent to which flows are needed to protect existing habitat and biota or to provide sufficient water for downstream domestic and livestock users. Site specific studies of a particular stream reach are required to effectively establish the necessary minimum flows, but for relatively small appropriations, the TCEQ often uses default methodologies to estimate the flow bypass requirements for instream environmental uses.

There is some degree of uncertainty as to if or how such requirements for instream flows might be imposed on a new water right for a recharge project because of the complexities associated with the overall streamflow-recharge process at a particular location. In the portions of the GSA and Nueces basins where recharge facilities are most likely to be located, the streams being considered for such facilities often are characterized by intermittent flows that occur in response to rainfall events; hence, most of the available supplies of unappropriated source water are likely to occur during floods and high runoff periods, not during low-flow conditions. During low-flow conditions, most of the flow in the streams does not make it across the recharge zone; therefore, there is no flow downstream of the recharge zone and no rationale for implementing environmental flow restrictions. During floods and high runoff periods, it is reasonable to believe that typically there will be some quantity of streamflow that cannot be effectively captured and diverted for purposes of R&R. The extent to which such bypassed flows would fulfill the downstream needs for satisfying instream uses has not been analyzed in this study, but certainly such overflows from the recharge facilities would contribute to these downstream flow requirements.

Neglect of environmental flow pass-through requirements may result in an over-estimation of recharge enhancement for some projects, particularly those sites for which monthly median flow is greater than zero. This complex issue regarding what, if any, environmental flow requirements may be imposed by the TCEQ on a new or amended permit for source water for R&R purposes will need to be examined further if results from this preliminary assessment of potential R&R projects without such instream flow requirements indicate that further consideration is warranted.

SOURCE WATER ESTIMATIONS FOR 1990-2000

The simulation period for the EAA groundwater model extends from 1947 through 2000, which is longer than the simulation periods for either the GSA WAM (1989) or the Nueces WAM (1996). Consequently, monthly quantities for unappropriated water and marketable water had to be estimated for the 1990-2000 period in the GSA basin and for the 1997-2000 period in the Nueces basin. These estimates were based on regression equations developed using simulated values of historical quantities from the WAMs and corresponding historical streamflows at gages in the vicinity of the R&R project locations, taking into consideration storage in reservoirs.

In developing the required regression equations, difficulties initially were encountered with correlations between the WAM simulated unappropriated water values and the corresponding gaged flows because of the fact that in some cases there are significant differences in the basic conditions underlying these values. The WAMs' simulated unappropriated flows are based on full authorized diversion amounts for all water rights and as-built storage capacities for all permitted reservoirs, with all water rights assumed to be in existence throughout the simulation period regardless of when they actually were authorized and became active. In addition, the WAMs assume that all water rights are satisfied in priority order. These fundamental concepts are not necessarily reflected in the historical real-world conditions that are embedded in the observed streamflow records used in the correlations. Generally, the observed flows only reflect whatever water use was made (or not made) at and upstream at the time of the flow observations. Whatever water use was actually made was likely without regard to senior downstream water needs.

After reviewing available streamflow and reservoir content records near or associated with each of the potential R&R project locations for the WAM simulation periods and through the year 2000, it was determined that different regression approaches would be needed depending on the hydrologic circumstances associated with each of the project sites. In particular, the effects of major reservoirs reflected in all results from the WAMs but not in the gaged flow records had to be taken into account. Following is a description of the approaches used at particular locations to estimate the monthly unappropriated water values for the periods outside of the WAM simulation periods. The resulting regression equations and associated variables at each of the recharge/recirculation project locations are summarized in Table 5-1.

- Correlation of Historical Monthly Gaged Flows with Monthly WAM Unappropriated Water Values - This direct correlation approach was used for the Lower Blanco, Cibolo Dam, and San Geronimo sites in the GSA basin since neither the simulated unappropriated water values from the WAMs nor the historical flows from gages near these sites were influenced by major reservoirs.
- Correlation of Historical Gage Flows with WAM Unappropriated Water Values with the Inclusion of a Reservoir Storage Threshold - For many of the potential R&R sites where streamflows are hydrologically affected by major reservoirs such as Canyon

Lake, Medina Lake, and Choke Canyon Reservoir, many instances occurred where the associated gaged flows were significant, but the corresponding unappropriated water values as simulated with the WAMs were zero. This, in large part, was the result of low storage conditions in associated reservoirs such that even though flow conditions were relatively high, these high flows were not simulated with the WAMs as being unappropriated because the associated reservoirs were not full. To overcome these effects in the development of the unappropriated water versus gaged flow regression relationships, storage thresholds for the associated reservoirs were established to eliminate (or minimize) data sets when large flows were observed but zero unappropriated water was reported by the WAMs. This approach was used for the potential R&R sites at Comfort, Canyon Lake, Lake Dunlap, Comal Springs, and Medina Lake in the GSA basin and at Lower Hondo and Lower Verde in the Nueces basin.

- Setting All Unappropriated Water Values to Zero - For the three westernmost R&R sites in the Nueces basin (Lower Sabinal, Lower Frio and Indian Creek), useful correlations between unappropriated water values and corresponding gage flows could not be developed because of insufficient unappropriated water data from the WAM simulations. Additionally, with Choke Canyon Reservoir in operation in the WAM for the entire simulation period, unappropriated water was indicated to be available less than three percent of the time, which limited the development of reasonable correlations. Consequently, the unappropriated water values for the Nueces extension period (1996-2000) at these three sites were set to zero.

Table 5-1: Summary of Regressions of Unappropriated Water with Gaged Flow

LOCATION NAME	WAM PERIOD OF RECORD	CORRELATION PERIOD	STREAMFLOW GAGE USED	RESERVOIR GAGE USED	RESULTING EQUATION	R2 VALUE
GUADALUPE RIVER BASIN						
Period of Extension: 1990-2000						
Comfort	1934-1989	1964-1989	Guadalupe @ Comfort	Canyon Lake near Sattler	$y = 0.9597x - 4938.1$	0.97
Canyon Lake	1934-1989	1964-1989	Guadalupe @ Sattler	Canyon Lake near Sattler	$y = 0.5449x - 16.251$	0.53
D/S Comal Springs	1934-1989	1964-1989	Guadalupe @ New Braunfels	Canyon Lake near Sattler	$y = 0.1556x + 479.49$	0.57
Lake Dunlap	1934-1989	1964-1989	Guadalupe @ New Braunfels	Canyon Lake near Sattler	$y = 0.6881x - 9690.7$	0.57
Medina Lake	1934-1989	1953-1973	Medina near Riomedina	Medina Lake	$y = 0.5692x - 1058.6$	0.90
San Geronimo	1934-1989	1979-1989	San Antonio @ Loop 410 (upstream)	None	$y = 0.7517x - 36.323$	0.74
Lower Blanco	1934-1989	1934-1989	Blanco @ Wimberley	None	$y = 1.031x - 2160.6$	0.90
Cibolo Creek	1934-1989	1946-1989	Cibolo near Selma	None	$y = 1.4582x - 40.81$	0.96
NUECES RIVER BASIN						
Period of Extension: 1997-2000						
Lower Hondo	1934-1996	1985-1996	Hondo near Tarpley	Choke Canyon near Three Rivers	$y = 0.1666x - 51.525$	0.97
Indian Creek	1934-1996	1985-1996	Frio @ Concan	Choke Canyon near Three Rivers	n/a	n/a
Lower Frio	1934-1996	1985-1996	Frio @ Concan	Choke Canyon near Three Rivers	n/a	n/a
Lower Sabinal	1934-1996	1985-1996	Sabinal near Sabinal	Choke Canyon near Three Rivers	n/a	n/a
Lower Verde	1934-1996	1985-1996	Hondo near Tarpley	Choke Canyon near Three Rivers	$y = 0.0187x + 40.136$	0.22

5.1.2. GSA BASIN R&R SOURCE WATER

The Run 3 and Run 8 versions of the GSA WAM as modified for purposes of this study were operated, and simulated values of unappropriated water were extracted from the output for each of the sites identified as potential locations for recharge/recirculation projects in the GSA basin. These sites are listed in Table 5-2 along with the identifications of the corresponding WAM control points where the simulated unappropriated water values were extracted. Monthly values of marketable water for each of these sites were calculated using the procedures outlined above. Complete tabular printouts of the monthly values of unappropriated water and marketable water for each of the GSA basin R&R project sites are contained in Appendix B of this report.

Table 5-2: GSA WAM Control Point Assignments for R&R Sites in the GSA Basin

RECHARGE/ RECIRCULATION PROJECT SITE	GSA WAM CONTROL POINT ID*
Comfort	CP01
Canyon Lake	CP03
D/S Comal Springs	382803
Lake Dunlap	CPDUN
Medina Lake	CP21
San Geronimo	322031
Lower Blanco	LBTEST (CP09)
Cibolo Creek	CDTEST (CP34)

*Control Point IDs with “TEST” in the name were created in this study to properly represent the locations of the proposed R&R project sites in the WAMs. The ID in parentheses following each of these Control Point IDs is for the next downstream control point in the original WAMs.

Table 5-3 presents a summary of statistical parameters for the monthly and annual values of unappropriated water for each of the potential R&R sites in the GSA basin. Parameters include average, maximum, 75-percentile, 50-percentile, 25-percentile, and minimum values. A similar summary for the marketable water values is presented in Table 5-4. The complete data set is provided in Appendix B.

As shown and as expected, values vary considerably among the different locations within the basin as hydrologic and watershed conditions vary from stream to stream. Varying levels of appropriation for existing water rights on different streams and varying amounts of water usage also have an effect on these results. All of these factors influence unappropriated and marketable water throughout the basin. Generally, unappropriated water values are greater than corresponding marketable water values, but there are times when the reverse also occurs at some locations, again as these same factors come into play. The sum of unappropriated water and marketable water would represent a maximum amount of potential water available for purchase/permitting and use for recharge.

Table 5-3: Summary of Unappropriated Water for Potential R&R Sites in the GSA Basin (AF)

SITE	JAN	FEB	MAR	APR	MAY	JUN	JUL	AUG	SEP	OCT	NOV	DEC	TOTAL
COMFORT													
AVG	1,697	3,559	4,265	3,643	3,238	6,187	2,585	2,837	1,953	1,680	2,010	2,133	35,787
MAX	10,736	90,446	87,079	48,597	42,827	146,450	34,994	30,052	25,385	17,630	14,988	11,143	370,784
75%	2,095	3,625	4,294	3,830	2,782	4,431	987	0	2	100	825	3,329	48,394
50%	0	0	0	0	0	1	0	0	0	0	0	0	24,989
25%	0	0	0	0	0	0	0	0	0	0	0	0	0
MIN	0	0	0	0	0	0	0	0	0	0	0	0	0
CANYON LAKE													
AVG	4,070	5,001	7,421	7,896	11,747	16,581	7,466	3,988	3,147	4,979	2,358	3,595	78,249
MAX	100,064	74,632	132,294	128,907	95,060	365,155	177,861	175,393	157,687	77,238	49,014	90,133	606,986
75%	0	0	3,725	0	9,522	3,122	0	0	0	0	0	0	100,550
50%	0	0	0	0	0	0	0	0	0	0	0	0	11,191
25%	0	0	0	0	0	0	0	0	0	0	0	0	0
MIN	0	0	0	0	0	0	0	0	0	0	0	0	0
DOWNSTREAM COMAL SPRINGS													
AVG	1,957	2,475	3,402	2,800	4,743	3,134	2,049	821	806	2,783	1,580	1,693	28,243
MAX	23,837	23,346	41,183	35,907	49,710	28,397	50,573	12,460	14,771	20,614	21,785	27,433	185,498
75%	0	0	2,497	1,230	5,098	1,847	0	0	4	2,193	1	0	46,071
50%	0	0	0	0	0	0	0	0	0	0	0	0	14,431
25%	0	0	0	0	0	0	0	0	0	0	0	0	0
MIN	0	0	0	0	0	0	0	0	0	0	0	0	0
LAKE DUNLAP													
AVG	4,015	5,331	7,998	8,297	12,379	16,872	7,686	3,764	3,002	5,803	2,418	3,778	81,343
MAX	99,834	84,478	170,309	146,978	121,472	364,316	211,834	174,989	157,325	77,060	58,974	89,926	690,394
75%	0	0	1,530	729	6,592	1,012	0	0	0	1,597	0	0	111,443
50%	0	0	0	0	0	0	0	0	0	0	0	0	14,422
25%	0	0	0	0	0	0	0	0	0	0	0	0	0
MIN	0	0	0	0	0	0	0	0	0	0	0	0	0
MEDINA LAKE													
AVG	473	1,305	991	1,186	2,490	6,068	2,591	968	1,977	1,863	1,081	357	21,349
MAX	13,470	52,138	27,169	27,805	50,458	232,443	118,294	51,671	111,703	43,971	23,584	6,785	334,172
75%	0	0	0	0	0	0	0	0	0	0	0	0	2,991
50%	0	0	0	0	0	0	0	0	0	0	0	0	0
25%	0	0	0	0	0	0	0	0	0	0	0	0	0
MIN	0	0	0	0	0	0	0	0	0	0	0	0	0
SAN GERONIMO													
AVG	145	205	239	324	992	873	151	59	185	805	211	230	4,418
MAX	4,068	3,035	4,293	5,139	26,586	14,175	4,515	1,533	3,484	35,590	3,779	7,125	37,600
75%	0	0	0	0	699	630	0	0	2	125	1	8	6,607
50%	0	0	0	0	0	0	0	0	0	0	0	0	1,583
25%	0	0	0	0	0	0	0	0	0	0	0	0	0
MIN	0	0	0	0	0	0	0	0	0	0	0	0	0
LOWER BLANCO													
AVG	5,944	7,139	7,989	8,527	10,420	13,199	4,085	738	2,841	6,075	5,334	6,441	78,731
MAX	81,612	80,906	59,748	54,589	70,810	139,410	50,047	9,557	27,245	81,632	48,644	84,278	321,323
75%	5,290	7,255	11,408	12,076	17,990	13,884	2,516	446	2,476	3,763	6,000	5,747	143,624
50%	715	1,154	1,690	3,515	3,620	2,079	0	0	59	614	1,379	1,949	48,367
25%	0	0	0	0	0	0	0	0	0	0	0	0	14,285
MIN	0	0	0	0	0	0	0	0	0	0	0	0	0
CIBOLO DAM													
AVG	833	1,319	1,945	1,248	4,130	5,645	1,799	271	1,066	3,432	371	1,913	23,972
MAX	34,912	54,115	43,300	19,773	58,507	135,888	98,175	7,585	33,705	154,391	10,926	102,436	170,360
75%	0	0	0	0	1,026	454	0	0	0	121	0	0	31,789
50%	0	0	0	0	0	0	0	0	0	0	0	0	5,981
25%	0	0	0	0	0	0	0	0	0	0	0	0	10
MIN	0	0	0	0	0	0	0	0	0	0	0	0	0

Table 5-4: Summary of Marketable Water for Potential R&R Sites in the GSA Basin (AF)

SITE	JAN	FEB	MAR	APR	MAY	JUN	JUL	AUG	SEP	OCT	NOV	DEC	TOTAL
COMFORT													
AVG	835	1,101	307	2,137	1,308	3,320	1,508	2,092	1,273	2,099	218	1,766	17,962
MAX	16,221	26,697	3,154	41,964	32,467	162,329	63,914	101,701	25,670	61,534	5,172	41,077	166,808
75%	0	0	0	702	75	1,059	579	0	0	0	0	0	21,753
50%	0	0	0	0	0	0	0	0	0	0	0	0	4,406
25%	0	0	0	0	0	0	0	0	0	0	0	0	0
MIN	0	0	0	0	0	0	0	0	0	0	0	0	0
CANYON LAKE													
AVG	5,594	5,458	6,290	5,526	7,664	7,125	3,663	2,605	4,388	6,550	4,732	5,201	64,796
MAX	34,269	46,424	26,250	22,103	65,576	45,908	26,883	50,770	67,441	36,150	25,751	24,780	211,605
75%	9,051	5,573	15,228	9,777	14,231	14,478	0	0	0	7,503	9,518	10,382	107,759
50%	0	0	0	0	148	0	0	0	0	0	0	0	67,354
25%	0	0	0	0	0	0	0	0	0	0	0	0	0
MIN	0	0	0	0	0	0	0	0	0	0	0	0	0
DOWNSTREAM COMAL SPRINGS													
AVG	2,721	1,886	2,472	3,223	2,841	2,760	1,809	1,008	2,671	1,677	2,681	3,369	29,118
MAX	19,251	14,782	18,906	19,427	18,098	19,510	16,430	10,484	29,415	15,323	18,800	17,039	95,051
75%	3,221	3,090	2,449	5,780	1,454	1,077	0	0	0	14	3	6,880	46,535
50%	0	0	0	0	0	0	0	0	0	0	0	0	21,203
25%	0	0	0	0	0	0	0	0	0	0	0	0	1,070
MIN	0	0	0	0	0	0	0	0	0	0	0	0	0
LAKE DUNLAP													
AVG	6,330	5,610	6,719	6,022	9,713	7,851	3,994	2,622	4,953	7,127	4,959	5,454	71,355
MAX	34,190	46,318	29,423	27,110	79,793	45,947	26,821	50,653	75,693	36,068	26,901	25,698	219,583
75%	11,017	6,092	15,743	9,755	20,079	16,487	0	0	410	9,634	9,541	10,358	120,841
50%	0	0	0	0	148	0	0	0	0	0	0	0	74,190
25%	0	0	0	0	0	0	0	0	0	0	0	0	1,070
MIN	0	0	0	0	0	0	0	0	0	0	0	0	0
MEDINA LAKE													
AVG	0	839	0	295	188	2,546	1,231	149	3	405	0	168	5,823
MAX	0	28,804	0	16,495	10,198	100,647	68,915	8,364	172	22,705	0	9,397	100,647
75%	0	0	0	0	0	0	0	0	0	0	0	0	0
50%	0	0	0	0	0	0	0	0	0	0	0	0	0
25%	0	0	0	0	0	0	0	0	0	0	0	0	0
MIN	0	0	0	0	0	0	0	0	0	0	0	0	0
SAN GERONIMO													
AVG	0	6	9	5	12	33	6	16	144	32	12	16	292
MAX	1	333	342	138	230	801	157	420	6,041	1,137	278	510	6,221
75%	0	0	0	1	1	2	0	0	1	1	1	1	372
50%	0	0	0	0	0	1	0	0	0	0	0	0	10
25%	0	0	0	0	0	0	0	0	0	0	0	0	0
MIN	0	0	0	0	0	0	0	0	0	0	0	0	0
LOWER BLANCO													
AVG	1,831	1,881	973	1,169	615	144	77	99	2,017	619	379	721	10,526
MAX	17,589	13,202	11,189	11,223	9,408	2,468	1,316	2,332	66,379	7,421	5,244	15,874	71,085
75%	3,263	1,784	93	541	93	108	119	76	390	302	36	33	16,633
50%	38	29	41	54	75	104	0	0	76	41	26	24	4,782
25%	25	26	0	1	0	0	0	0	0	0	20	20	2,608
MIN	0	0	0	0	0	0	0	0	0	0	0	0	0
CIBOLO DAM													
AVG	0	1	0	13	0	104	0	4	130	1	0	0	253
MAX	0	65	0	434	0	4,603	0	211	7,131	52	23	0	7,131
75%	0	0	0	0	0	0	0	0	0	0	0	0	0
50%	0	0	0	0	0	0	0	0	0	0	0	0	0
25%	0	0	0	0	0	0	0	0	0	0	0	0	0
MIN	0	0	0	0	0	0	0	0	0	0	0	0	0

5.1.3. NUECES BASIN R&R SOURCE WATER

The Run 3 and Run 8 versions of the Nueces WAM as modified for purposes of this study also were operated, and simulated values of unappropriated water were extracted from the output for each of the sites identified as potential locations for R&R projects in the Nueces basin. These sites are listed in Table 5-5 along with the identification of the corresponding WAM control points where the simulated unappropriated water values were extracted. Monthly values of marketable water for each of these sites were calculated using the procedures outlined above. Complete tabular printouts of the monthly values of unappropriated water and marketable water for each of the Nueces basin recharge/recirculation project sites are contained in Appendix B of this report.

Table 5-5: Nueces WAM Control Point Assignments for R&R Sites in the Nueces Basin

RECHARGE/RECIRCULATION PROJECT SITE	NUECES WAM CONTROL POINT ID*
Lower Hondo	LHTEST (CP19)
Indian Creek	ICTEST (307202)
Lower Frio	417701
Lower Sabinal	LSTEST (318201)
Lower Verde	LVTEST (CP22)

*Control Point IDs with “TEST” in the name were created in this study to properly represent the locations of the proposed recharge/recirculation project sites in the WAMs. The ID in parentheses following each of these Control Point IDs is for the next downstream control point in the original WAMs.

Table 5-6 presents a summary of statistical parameters for the monthly and annual values of unappropriated water for each of the potential R&R sites in the Nueces basin. Parameters are the same as those presented for the GSA basin. A similar summary for the marketable water values is presented in Table 5-7. As with the GSA basin, values in the Nueces basin vary considerably among the different locations within the basin as hydrologic and watershed conditions vary from stream to stream, as do appropriations for existing water rights and water usage. Different from the GSA basin, however, the unappropriated water in the Nueces basin often is less than marketable water, suggesting that more of the available streamflow in the Nueces has already been appropriated and that actual usage in the Nueces has not approached appropriated levels. But as in the GSA basin, there are times when the reverse also occurs at some locations.

Table 5-6: Summary of Unappropriated Water for Potential R&R Sites in the Nueces Basin (AF)

SITE	JAN	FEB	MAR	APR	MAY	JUN	JUL	AUG	SEP	OCT	NOV	DEC	TOTAL
LOWER HONDO													
AVG	81	67	63	52	22	833	255	62	162	69	78	66	1,811
MAX	1,046	966	887	533	207	53,234	14,024	2,509	10,005	2,130	1,276	954	79,772
75%	67	56	43	41	1	18	28	11	2	31	43	63	850
50%	1	3	0	0	0	0	0	0	0	0	0	0	395
25%	0	0	0	0	0	0	0	0	0	0	0	0	47
MIN	0	0	0	0	0	0	0	0	0	0	0	0	0
INDIAN CREEK													
AVG	75	0	0	651	384	10,504	579	2,262	152	2,891	879	207	18,584
MAX	5,033	0	0	43,627	16,667	630,606	29,619	151,572	7,024	172,385	17,294	13,844	633,797
75%	0	0	0	0	0	0	0	0	0	0	0	0	0
50%	0	0	0	0	0	0	0	0	0	0	0	0	0
25%	0	0	0	0	0	0	0	0	0	0	0	0	0
MIN	0	0	0	0	0	0	0	0	0	0	0	0	0
LOWER FRIO													
AVG	11	45	0	0	0	1,532	332	47	342	52	65	0	2,427
MAX	746	3,027	0	0	0	102,677	22,178	3,176	18,705	1,939	2,248	0	146,736
75%	0	0	0	0	0	0	0	0	0	0	0	0	0
50%	0	0	0	0	0	0	0	0	0	0	0	0	0
25%	0	0	0	0	0	0	0	0	0	0	0	0	0
MIN	0	0	0	0	0	0	0	0	0	0	0	0	0
LOWER SABINAL													
AVG	5	7	19	6	6	1,459	360	60	287	7	2	6	2,226
MAX	142	208	318	123	424	96,715	22,291	2,591	18,094	190	77	165	139,730
75%	0	0	0	0	0	0	0	0	0	0	0	0	61
50%	0	0	0	0	0	0	0	0	0	0	0	0	0
25%	0	0	0	0	0	0	0	0	0	0	0	0	0
MIN	0	0	0	0	0	0	0	0	0	0	0	0	0
LOWER VERDE													
AVG	3	13	20	28	32	227	152	32	161	37	43	30	777
MAX	72	148	236	232	222	13,143	8,053	236	8,162	285	240	213	29,676
75%	0	0	1	23	39	39	64	40	51	50	68	36	554
50%	0	0	0	0	0	0	0	0	0	0	4	4	314
25%	0	0	0	0	0	0	0	0	0	0	0	0	103
MIN	0	0	0	0	0	0	0	0	0	0	0	0	0

Table 5-7: Summary of Marketable Water for Potential R&R Sites in the Nueces Basin (AF)

SITE	JAN	FEB	MAR	APR	MAY	JUN	JUL	AUG	SEP	OCT	NOV	DEC	TOTAL
LOWER HONDO													
AVG	10	6	23	53	619	1,156	82	13	667	194	80	7	2,911
MAX	237	49	960	2,756	29,779	66,855	1,374	126	27,301	7,907	4,384	58	97,966
75%	10	11	16	22	32	58	36	15	21	15	10	8	526
50%	0	0	1	0	0	0	0	0	0	0	0	0	179
25%	0	0	0	0	0	0	0	0	0	0	0	0	53
MIN	0	0	0	0	0	0	0	0	0	0	0	0	3
INDIAN CREEK													
AVG	187	569	816	54	1,756	2,853	765	120	1,333	2,857	413	185	11,908
MAX	8,062	22,950	51,429	2,919	58,297	161,514	24,094	7,062	32,477	128,034	12,303	8,590	161,859
75%	0	0	0	0	0	0	0	0	0	0	0	0	5,921
50%	0	0	0	0	0	0	0	0	0	0	0	0	0
25%	0	0	0	0	0	0	0	0	0	0	0	0	0
MIN	0	0	0	0	0	0	0	0	0	0	0	0	0
LOWER FRIO													
AVG	460	565	815	552	1,270	1,790	792	336	1,938	756	660	772	10,707
MAX	3,949	2,449	4,817	3,204	31,468	79,103	17,638	2,662	55,193	15,689	9,783	4,425	132,994
75%	493	1,112	1,152	972	1,274	685	809	501	828	827	833	1,361	10,545
50%	0	0	0	0	0	0	0	0	114	0	0	0	6,938
25%	0	0	0	0	0	0	0	0	0	0	0	0	4,266
MIN	0	0	0	0	0	0	0	0	0	0	0	0	0
LOWER SABINAL													
AVG	0	28	70	103	738	1,559	268	20	1,161	312	159	50	4,469
MAX	1	816	2,878	5,716	25,541	92,958	13,004	856	51,618	14,229	8,530	1,590	131,503
75%	0	0	0	0	1	0	0	0	0	0	0	0	917
50%	0	0	0	0	0	0	0	0	0	0	0	0	110
25%	0	0	0	0	0	0	0	0	0	0	0	0	0
MIN	0	0	0	0	0	0	0	0	0	0	0	0	0
LOWER VERDE													
AVG	0	0	0	86	318	434	49	3	52	42	26	0	1,011
MAX	0	0	0	5,445	13,863	22,862	3,056	197	1,926	1,801	1,634	0	39,978
75%	0	0	0	0	0	0	0	0	0	0	0	0	0
50%	0	0	0	0	0	0	0	0	0	0	0	0	0
25%	0	0	0	0	0	0	0	0	0	0	0	0	0
MIN	0	0	0	0	0	0	0	0	0	0	0	0	0

5.2. UNUSED EDWARDS AQUIFER PERMITS

EAA issues withdrawal permits, allowing a permit holder to pump a certain amount of water from the aquifer each year subject to any CPM withdrawal reductions. Not all permit holders pump their entire allocation each year, leaving some amount of groundwater available for lease or purchase by others. These unused permits account for a significant amount of water, especially during wet years when groundwater pumping is generally less. Although the potential exists for unused permits to be leased or purchased and used by other groundwater pumpers, the largest volumes appear to occur in wet years when water is available from other sources and is not needed by other users. Therefore, the unused

permit portion could be potentially leased/purchased for conveyance back to the aquifer recharge zone as an R&R strategy.

At first, the concept of pumping groundwater already in storage back to the recharge zone may seem non-beneficial. However, because of geologic complexities within the aquifer system, the strategy allows for the movement of water to certain recharge sites to accomplish specific goals. For example, pumping away from the springs and recharging close to the springs could assist with maintaining springflow during critical times. Conversely, moving groundwater in storage to recharge sites west of localized fault blocks could ultimately increase water in long-term storage.

To assess the amount of unused permits that may serve as source water for enhancing recharge, EAA staff evaluated the permitted and actual withdrawals from the Edwards Aquifer and provided those data to Todd Engineers for this study. Data were compiled from 1999 through 2006 for Uvalde, Medina, Bexar, Comal, Hays, Atascosa, and Guadalupe counties. Small amounts of unused rights from Atascosa and Guadalupe counties (collectively averaging less than 220 AFY) were not included in the analysis. Amounts were corrected for any reductions in pumping that occurred because of CPM rules. Average amounts by county and water use are summarized in the table below.

Table 5-8: Average Amounts of Unused Pumping Permits by County and Water Use

Pool	County	Average Unused Permits 1999-2006		
		Irrigation (AFY)	Muni/Ind. (AFY)	TOTAL (AFY)
Uvalde Pool				
	Uvalde	66,631	1,241	67,872
San Antonio Pool				
	Medina	54,478	2,840	57,318
	Bexar	25,717	22,044	47,761
	Comal	951	6,993	7,944
	Hays	867	4,243	5,110
	Subtotal	82,013	36,120	118,133
TOTAL		148,644	37,361	186,005

As shown by the table, average unused permits over the last eight years totaled 67,872 AFY in the Uvalde Pool and 118,133 AFY in the San Antonio Pool for a total average amount of 186,005 AFY. These data indicate that, for average conditions, a large amount of groundwater may be available for purchase or lease for the purposes of aquifer recharge. Although irrigation permits represent 80 percent of the average unused permit types, potential municipal and industrial sources represent more water on an average basis (37,361 AFY) than available from unappropriated streamflow at most Type 2 recharge sites (Table 5-4, lower 3 sites, and Table 5-6).

Annual data are summarized on the following graph for both the Uvalde and San Antonio pools illustrating the variability in available water over time. This variability is likely related to annual changes in water demand and availability of additional water sources (including rainfall).

Illustration 5-1: Unused Withdrawal Permits 1999 – 2006

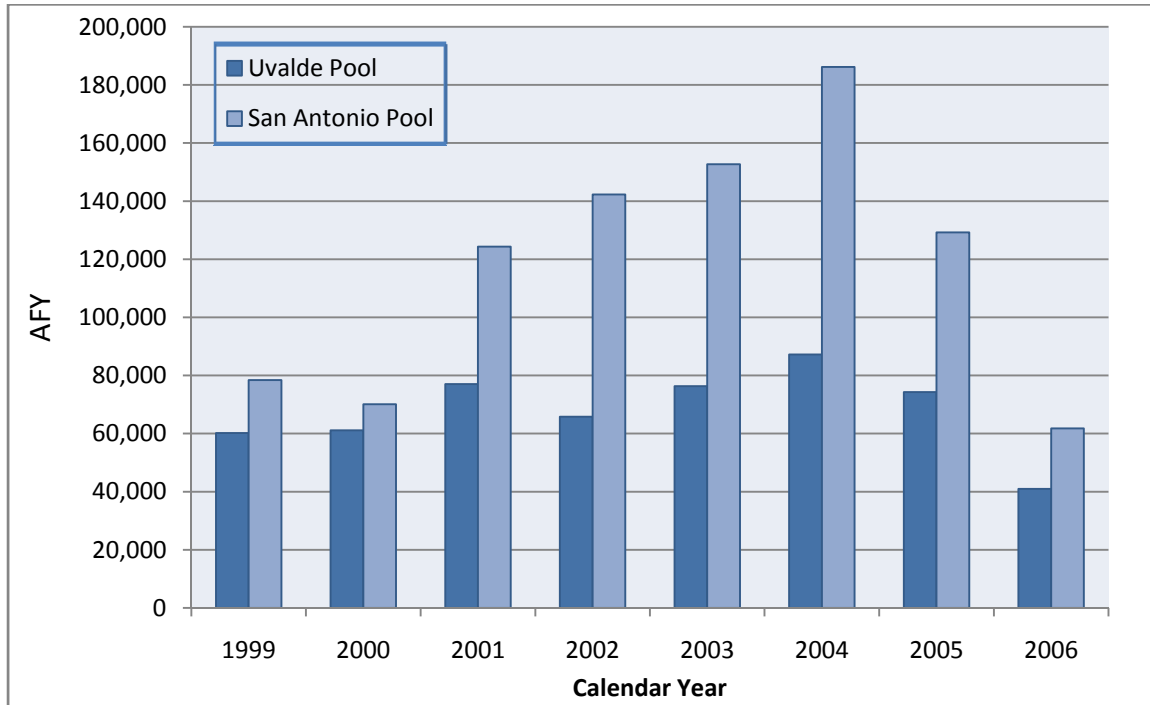

As shown above, unused permits in the Uvalde Pool range from 40,986 AFY in 2006 up to about 87,203 AFY in 2004. More variability exists in the San Antonio Pool, which covers multiple counties with varying hydrologic conditions. Over this eight-year period, unused permits for the San Antonio Pool range from 61,811 AFY in 2006 to 186,185 AFY in 2004.

The variability in unused permits correlates reasonably well with average annual rainfall at representative stations across the aquifer. The following graph on Illustration 5-2 presents rainfall data for 1999-2006 to examine this correlation.

Illustration 5-2: Precipitation at Selected Stations across the Edwards Aquifer

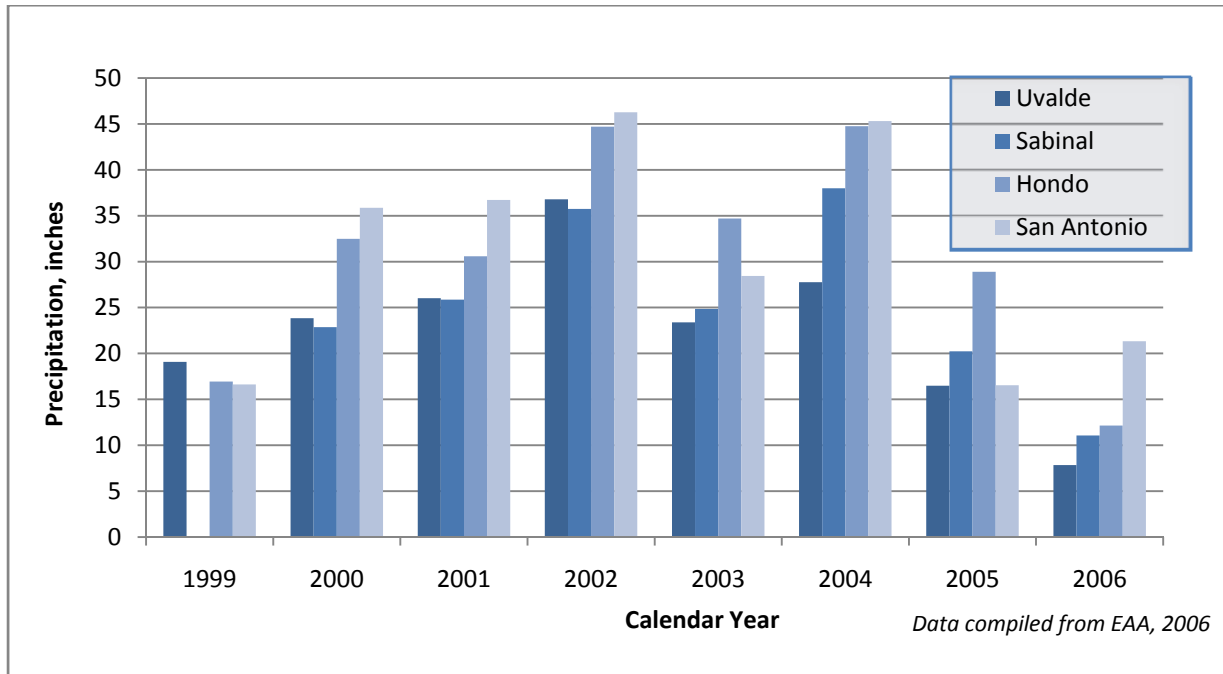

The graph shows that 2002 and 2004 were the wettest years across the basin with relatively dry periods in 1999 and 2006. A comparison of the bar graphs on Illustrations 5-1 and 5-2 indicates that more unused water is generally available during wet periods. For Uvalde County, the average annual precipitation for 1999-2006 was 22.7 inches, slightly drier but within about five percent of the long-term annual average of 24.02 inches. For the stations in the San Antonio Pool, average annual precipitation for 1999-2006 (25.52 inches, 30.65 inches, 30.89 inches) was also within about five percent of the long-term averages (25.03 inches, 29.16 inches, 30.3 inches). Because this period incorporated all of the data and covered generally average hydrologic conditions, the average of unused permit water for this time period was selected as a representative average for each pool as shown on Table 5-8.

According to EAA permit rules, one-half of the permit amount is tied to the parcel for which an irrigation permit is held (base permit) and generally cannot be pumped on other lands, as would be necessary for R&R pumping (EAA, 2008). Data were unavailable to determine whether the unused rights compiled for this study represented all or some portion of the base permit. That is, it was unknown whether the unused rights represented irrigation permit holders who were pumping *none* of their allocation (making the amount of unused rights subject to the base permit) or those who were pumping *a portion* of their allocation (with the remaining or unused amount being above the base).

In the absence of data, it was assumed that one-half of the unused irrigation permits contained a full base portion and one-half did not. As such, one-half of the unused irrigation

permits were reduced by 50 percent to account for the restriction on pumping location. Using this methodology, the total unused irrigation amount is reduced by 25 percent from 66,631 AFY to 49,973 AFY for the Uvalde Pool and from 82,013 AFY to 61,510 AFY for the San Antonio Pool. Adding these amounts to the available municipal/industrial amounts indicates an average of 51,215 AFY available from the Uvalde Pool and 97,630 AFY available from the San Antonio Pool.

For modeling purposes, these amounts represent potential source water for R&R pumping and were applied on an average basis for each year of the model. These amounts were further reduced by CPM withdrawal reductions in either the Uvalde or San Antonio pools when appropriate, allowing the model to correct for time periods when less unused permits would potentially be available.

5.3. EXCESS SPRINGFLOW FROM RECIRCULATION

For the purposes of this Phase III analysis, excess springflow is specifically defined as the amount of springflow that can be attributed to enhanced recharge strategies. It is not necessarily in excess of the springflow amounts needed to protect endangered species or meet environmental needs. Further, there is uncertainty as to whether this water could be available from a regulatory basis. However, we are analyzing options for use of this water as a potential source of recirculation as required by our Scope of Services (Appendix A).

The method for excess springflow determination involves numerous model simulations with varying amounts of recharge and timing in all of the Type 2 sites, both individually and together. Preliminary model runs from Chapter 4 were used to assess the general percentages of recharge contribution to springflow over varying hydrologic conditions and over time. Numerous additional runs described in the following chapters were used to produce reasonable estimates of source water that could be recirculated for recharge at the R&R project sites. Although these estimates vary according to the amount of recharge and sites simulated, available amounts vary from about 25,000 AFY to more than 160,000 AFY.

The EAA Act specifically prohibits recirculating water from the springs pool at Comal and San Marcos springs (Texas State Legislature, 1993). As such, R&R strategies assume that excess springflow amounts are retrieved downstream at the Lake Dunlap diversion location. The excess springflow from enhanced recharge is assumed to be additive to estimates of unappropriated water potentially available at the Lake Dunlap diversion. As previously discussed, the WAM used to develop the Dunlap unappropriated rights was adjusted to the lower springflow amounts associated with baseline conditions. As such, all downstream rights have already been satisfied prior to allowing water to be deemed unappropriated.

6. EVALUATION OF POTENTIAL R& R COMPONENTS

The combination of new baseline conditions (Chapter 3), re-evaluation of aquifer response to recharge (Chapter 4), and updated source water estimates (Chapter 5) dictated the need for components of the R&R strategies to be evaluated separately before combining them into meaningful scenarios. This extra analysis allowed for the individual assessment of an R&R component's impact on critical period rules, water levels, springflow, and aquifer storage. For the purposes of this analysis, a component designates a specific location (such as one Type 2 site) linked to available source water (i.e., unappropriated or marketable streamflow, a new groundwater source, or recirculated water), either at that location or piped from a nearby source.

Although all of the components have the objectives of enhancing recharge and storage in the aquifer, they can be categorized as contributing primarily to either recharge or recirculation. For the purposes of this study, recharge components are defined as containing a new source of water for enhanced recharge, including the capture of surface water crossing the recharge zone, surface water diverted to the recharge zone, or using unused withdrawal permits to pump groundwater to the recharge zone. Recirculation components involve recovery of a portion of enhanced recharge either directly from groundwater (using ARSR recovery permits) or after discharge at springs. In applying this definition, the proposed wellfields could serve as a recharge component (pumping water associated with unused permit to the recharge zone) or as a recirculation component (pumping for recovery of recharge credits). In accordance with EAA rules, pumping as a recharge component would be subject to CPM withdrawal reductions, but pumping as a recirculation component would be exempt from CPM reductions (EAA, 2008).

The first half of this chapter describes the components and provides methods and assumptions that were used in the analysis. The second half of the chapter presents the results of the groundwater modeling.

6.1. DESCRIPTION OF COMPONENTS

Approximately 29 separate components were evaluated to better understand the fate of recharged water and to examine benefits to springflow and water supply. A list of the components evaluated in this study is shown on the following table. A description of the components and approach for analysis follows the table.

Table 6-1: List of Potential R&R Components

ID	Abbreviated Name for Model Simulation	Recharge Location	Source Water
1	IC Type 2 Unappropriated	Indian Creek Type 2	Unappropriated estimates from WAM
2	LF Type 2 Unappropriated	Lower Frio Type 2	Unappropriated estimates from WAM
3	LS Type 2 Unappropriated	Lower Sabinal Type 2	Unappropriated estimates from WAM
4	LH Type 2 Unappropriated	Lower Hondo Type 2	Unappropriated estimates from WAM
5	LV Type 2 Unappropriated	Lower Verde Type 2	Unappropriated estimates from WAM
6	SG Type 2 Unappropriated	San Geronimo Type 2	Unappropriated estimates from WAM
7	C Type 2 Unappropriated	Cibolo Dam Type 2	Unappropriated estimates from WAM
8	LB Type 2 Unappropriated	Lower Blanco Type 2	Unappropriated estimates from WAM
9	IC Type 2 Maximum	Indian Creek Type 2	Unappropriated plus marketable estimates from WAM
10	LF Type 2 Maximum	Lower Frio Type 2	Unappropriated plus marketable estimates from WAM
11	LS Type 2 Maximum	Lower Sabinal Type 2	Unappropriated plus marketable estimates from WAM
12	LH Type 2 Maximum	Lower Hondo Type 2	Unappropriated plus marketable estimates from WAM
13	LV Type 2 Maximum	Lower Verde Type 2	Unappropriated plus marketable estimates from WAM
14	SG Type 2 Maximum	San Geronimo Type 2	Unappropriated plus marketable estimates from WAM
15	C Type 2 Maximum	Cibolo Dam Type 2	Unappropriated plus marketable estimates from WAM
16	LB Type 2 Maximum	Lower Blanco Type 2	Unappropriated plus marketable estimates from WAM
17	All L-18 WAM Unappropriated	All Type 2 projects in Phase III study	Unappropriated estimates from WAM and pumping a portion from Indian Creek to Dry Frio and Lower Blanco to flood retention structures (pump-overs)
18	All L-18 HDR Available Water	All Type 2 projects in Phase III study	Recharge and pump-over amounts used by HDR in previous evaluations of the Phase III Type 2 sites

ID	Abbreviated Name for Model Simulation	Recharge Location	Source Water
19	L-18 (w/o LB) WAM Unappropriated	All Type 2 projects in Phase III study excluding Lower Blanco	Unappropriated estimates from WAM and Indian Creek pump-over
20	L-18 (w/o LB) HDR Available Water	All Type 2 projects in Phase III study excluding Lower Blanco	Recharge and pump-over amounts used by HDR in previous evaluations of the Phase III Type 2 sites with Lower Blanco excluded
21	Excess Springflow	All Type 2 projects in Phase III study plus excess springflow to Cibolo Dam	Unappropriated estimates from WAM, Indian Creek and Lower Blanco pump-overs plus excess springflow
22	Comfort and Medina to Hondo and Verde	Lower Hondo and Lower Verde Type 2s	Unappropriated estimates from WAM for Comfort diversion on Guadalupe River and Medina River at Medina Lake and unappropriated water at the Type 2 R&R sites
23	Canyon to Cibolo	Cibolo Dam Type 2	Unappropriated estimates from WAM for diversions from Canyon Lake and for Cibolo Creek Type 2 site
24	Dunlap to Cibolo	Cibolo Dam Type 2	Unappropriated estimates from WAM for diversions at Lake Dunlap and for Cibolo Creek Type 2 sites
25	Uvalde Unused Rights	New Uvalde County wellfield to Dry Frio recharge area	Unused withdrawal permits from Uvalde Pool
26	Medina Unused Rights	New Medina County wellfield to Seco Creek Sinkhole	Unused withdrawal permits from San Antonio Pool
27	Type 1	New Medina County wellfield to Upper Seco Creek Type 1 location	Unused withdrawal permits from San Antonio Pool
28	Comfort and Medina to San Geronimo	San Geronimo Type 2	Unappropriated estimates from WAM for Comfort diversion on Guadalupe River and Medina River at Medina Lake and unappropriated water at the Type 2 San Geronimo R&R site
29	Dunlap to San Geronimo	San Geronimo Type 2	Unappropriated estimates from WAM for Dunlap diversion location on Guadalupe and Type 2 on San Geronimo Creek

Components 1-20, 28, and 29 involve the analysis of enhanced recharge at the Type 2 structures, individually and in combination. Component 21 is an assessment of recirculating excess springflow as a result of enhanced recharge. Components 22-24, 28,

and 29 analyze the effects of diversions from three locations along the Guadalupe River and conveyance of the water to various Type 2 recharge structures. Components 25 and 26 analyze the use of unused withdrawal permits as an additional source of water for recharge.

A map showing the general location of project components is provided as Figure 6-1. Note that project components and pipeline locations are represented conceptually on the regional map. More detailed maps showing potential pipeline alignments are provided in Appendix C. Conceptual costs have also been developed for the R&R components and are included in Appendix C. Preliminary costs often represent the cost for capturing almost all available water to provide the upper range of costs for any component. These costs do not necessarily reflect the actual recommended component for R&R scenarios. Rather they were provided to evaluate economic constraints.

6.1.1. TYPE 2 RECHARGE SITES

The first 20 components analyzed for this project involved recharge at the Type 2 sites, both individually and combined. Sites are located on Figure 6-1. These analyses build on results of the preliminary model runs in Chapter 4, but include actual estimates of local source water as determined by the WAM analysis presented in Chapter 5. For these analyses, source water amounts were not corrected for potential losses to evaporation.

Two pipelines are incorporated into the Type 2 recharge site analysis and involve moving a portion of the water from a Type 2 site to a nearby location. These two strategies, referred to as pump-overs, allow captured streamflow to be percolated at two locations. Pump-overs for this analysis involve the eastern-most Type 2 site (Lower Blanco) and the western-most Type 2 site (Indian Creek) as described below.

The Lower Blanco site is associated with a large amount of unappropriated water, yet previous investigations have indicated locally high water levels and the limited potential for recharge. To better control the amount of recharge water that could be lost due to limited infiltration, a portion of the source water is conveyed westward to three existing floodwater retention structures (FRS). This management strategy, referred to as the Lower Blanco pump-over, has been proposed by previous investigators for maximizing recharge in this area (HDR, et al., 1998). Previous estimates of the amount of water that could be transmitted to these structures were provided to Todd Engineers by HDR (HDR, 2008). Previous proportions of recharge at Lower Blanco and the FRS structures were incorporated into this study.

An additional pump-over strategy, also developed by HDR, involved pumping a portion of the source water available at the Indian Creek Type 2 structure eastward to the Dry Frio River channel. The strategy was used to control water that was discharged quickly from Leona gravels/springs discharge in southern Uvalde County. Again, reasonable estimates of water that could be conveyed by pipeline to the Dry Frio area were provided by HDR (HDR,

2008). Similar proportions of water were allocated between the Indian Creek structure and the Dry Frio channel for this analysis.

6.1.2. GUADALUPE RIVER DIVERSIONS

Components 22 – 24, 28 and 29 examine benefits of diverting water from three locations along the Guadalupe River and conveying water to various Type 2 recharge structures. Conceptual pipeline alignments are shown on Figure 6-1. More detailed assessments of pipeline alignments are provided with component costs in Appendix C.

The diversion at Lake Dunlap (components 24 and 29) is the farthest downstream of the three Guadalupe River diversion sites and has the advantage of also being downstream of Comal Springs. This location would also be capable of recirculating excess springflow in addition to the WAM-derived estimates of source water at Lake Dunlap. The analysis examines conveyance of this water to the Cibolo Dam site (Component 24) and the San Geronimo Type 2 site (Component 29).

Component 23 analyzes the benefits of conveying unappropriated amounts of source water from Canyon Lake to the recharge zone. Previously-determined routes of conveyance were used to transmit this water to Medina County Type 2 sites. This route has been evaluated in the Region L planning process as water supply option G-32 (SCTRWPG, 2001). Water is diverted from the flood storage pool at Canyon Lake, conveyed to a tributary of Cibolo Creek via pipeline, and allowed to flow downstream to the Type 2 site for retention and infiltration. Although the projected capacity of the proposed Cibolo Dam project had limited the amount of recharge in past evaluations, all unappropriated water was simulated for the purposes of initial analysis.

Components 22 and 28 examine the diversion of unappropriated water near the town of Comfort and conveyance to a tributary of the Medina River. From there, water would flow downstream into Medina Lake and could be re-captured and conveyed via pipeline to a Type 2 recharge site. This routing is similar to that provided in the Region L planning process as water supply option G-30. Because unappropriated water may be available on the Medina River, along the conveyance route, this additional source water is incorporated into the analysis. Benefits from recharging at Lower Verde and Lower Hondo were evaluated. Because of the closer proximity, costs were later developed for conveyance to the San Geronimo recharge site.

6.1.3. RECIRCULATION OF EXCESS SPRINGFLOW

Component 21 involves the recirculation of springflow that results from enhanced recharge. Analyses included the identification of the amount of excess springflow and locations for recharge.

6.1.4. PUMPING OF UNUSED WITHDRAWAL RIGHTS

Components 25 and 26 involve the use of unused Edwards Aquifer withdrawal permits as a potential source of recharge water. It is assumed that this water could best be incorporated into R&R strategies through the siting of one or more new wellfields. From there water could be pumped and conveyed to the recharge zone by a new project-specific pipeline. A field investigation will be necessary to appropriately site and design such a wellfield. For purposes of modeling and analysis, preliminary locations for two wellfields, one in central Uvalde County and one in central Medina County, were identified. General wellfield locations are identified on Figure 6-1.

Considerations for wellfield location included the following:

- capability to capture water with a relatively short retention time and convey it to a recharge location with a relatively long retention time to increase long-term storage
- close proximity to a recharge area with sufficient capacity for the total volumes being pumped
- sufficient hydraulic conductivity and saturated thickness to yield high-capacity wells
- avoidance of areas with numerous existing wells
- compliance with EAA rules that prohibit water from being recharged outside the county from which it is pumped (applicable to both Uvalde and Medina counties)

For the Uvalde wellfield, insights from a recent hydrogeologic evaluation of the complex Knippa Gap in southeastern Uvalde County were considered (Green, et al., 2006). In that study, researchers from the Southwest Research Institute and Raba-Kistner Consultants provided a re-interpretation of an area of complex groundwater flow. The interpretations indicated that groundwater in central and southern Uvalde County, west of the gap, flowed south to discharge areas (Leona gravels/springs). Based on a preliminary water balance, the researchers indicated about 87,000 AFY are discharged in southern Uvalde, even when accounting for existing pumping (Green, et al., 2006).

Eastward flow across the southern portion of the Uvalde-Medina county line was thought to be impeded due to hydrogeologic complexities associated with the Uvalde Salient. However, north of this complex area, a subsurface channel appeared to be funneling groundwater eastward toward the San Antonio Pool (the Knippa Gap). This channel is also apparently fed by surface water recharge along the Frio and Sabinal rivers. Recharge west of the Frio River (including Indian Creek) apparently moves south. Based on these interpretations, there is an opportunity to capture groundwater that would be discharged at Leona by moving it to recharge areas associated with eastward groundwater flow. By intersecting groundwater southwest of the Knippa Gap, and recharging it along the Dry Frio/Frio river system, long-term aquifer storage may be enhanced. The preliminary location for such a wellfield is in south-central Uvalde County with a pipeline to Dry Frio River (Figure 6-1). A more detailed pipeline alignment and wellfield/conveyance costs are provided in Appendix C.

For recovery of unused permits from the San Antonio Pool, a wellfield could be located east of the complex fault zone associated with the Haby Crossing Fault in northern Medina County. USGS and others have noted complexities in groundwater flow in the fault complex and have interpreted groundwater to remain longer in storage in this area, a concept represented in the groundwater model. To take advantage of these complexities, a wellfield is sited east of the Haby Crossing Fault for recharge west of the fault. Seco Creek sinkhole was selected as the destination for this pumped water. This natural feature is currently being used by EAA to enhance streamflow recharge, but the capacity is apparently much larger than the available water. Due to the limited natural flow along Seco Creek, the structure is not being used to its potential. The site is also at a good hydrogeologic location for optimizing long-term aquifer storage. Figure 6-1 shows the conceptual wellfield and pipeline. A more detailed pipeline alignment and wellfield/conveyance costs are provided in Appendix C.

6.1.5. SELECTION OF A TYPE 1 RECHARGE STRUCTURE

A Type 1 recharge structure, sometimes referred to as a “catch and release” reservoir, is generally more costly to construct than Type 2 structures. In addition, some Type 1 structures are associated with more significant environmental impacts, given that large off-stream areas are inundated for relatively long periods of time. For these and other reasons, Type 1 facilities have not been included for implementation in recent regional water plans. However, Type 1 structures offer the operational flexibility of controlling the timing and amount of recharge. As such, our Phase III scope of work includes the selection and analysis of an example Type 1 site. This allows for an examination of potential benefits with new baseline conditions and the most current groundwater model.

Replacing or supplementing a Type 2 structure with a Type 1 structure was considered at each of the Type 2 sites. A Type 1 structure on the Blanco River would provide benefits to maintaining springflow at San Marcos Springs, as indicated by modeling and other investigations that show a rapid springflow response to local recharge. However, springflow at San Marcos Springs has not been shown to be the controlling factor or demonstrate chronic long-term impacts from R&R strategies. Under baseline conditions, springflow at San Marcos Springs did not trigger changes to critical periods since Comal Springs and Index Well J-17 reached trigger levels sooner. In addition, enhanced recharge water is more available year round for the Lower Blanco Type 2 structure. And because of the potential for previously-observed high water levels and rejected recharge, the available water appears to account for most of the recharge capacity that could be achieved. For these reasons, an expensive Type 1 facility does not appear justified at the Upper Blanco site.

A Type 1 structure located upstream of the Cibolo Dam site could provide a beneficial tool for maintaining springflows at Comal Springs, given the quick response of springflow to recharge at that location. However, good candidate Type 1 sites could not be identified on

Cibolo Creek by HDR during their preliminary scoping of Type 1 facilities (Vaugh, personal communication, 2008). Several sites appeared to be at risk of significant leakage of reservoir water into other formations. As such, a Type 1 was not simulated at Cibolo Creek. However, if such a site could be identified in the future, it could have significant management benefits for springflow maintenance.

For the western sites, a Type 1 structure at Indian Creek was judged to have potential benefits. Uncontrolled recharge at this location is likely to be discharged quickly at Leona gravels/springs and not contribute significantly to long-term storage. By capturing the relatively large quantities of water available and conveying that water over to Dry Frio/Frio river system, additional long term storage in the aquifer could be better achieved. Nonetheless, this Type 1 was eliminated from consideration due to the need to construct a long, large-capacity pipeline for conveyance to other drainages, relatively high preliminary costs (HDR, et al., 1991), and the sensitive nature of floodwater preservation on the downstream Nueces River as noted in EAA Act (Texas State Legislature, 1993).

Type 1 structures upstream of any of the centrally-located Type 2 recharge sites (Lower Verde, Lower Hondo, Seco Creek, Lower Sabinal, and Lower Frio) would allow similar benefits for long-term storage. Type 1 structures have been identified previously along each drainage, but several were associated with significant environmental impacts. Because each location was predicted to respond similarly in the groundwater model and because a pipeline for conveyance of unused permits was already being considered at the Seco Creek location, the Upper Seco Type 1 was selected for an example analysis of a Type 1 feature in the model. If a Type 1 structure is determined to be beneficial in the future, the potentially larger structures on Verde, Hondo, and Sabinal drainages should also be considered.

6.2. APPLICATION OF SOURCE WATER DATA

Quantities of the various source water available for recharge were presented in the previous chapter. This section documents methods, assumptions, and revisions to the total amount of source water as analyzed by groundwater modeling.

6.2.1. UNAPPROPRIATED AND MARKETABLE ESTIMATES

Unappropriated and marketable water estimates for the Type 2 enhanced recharge sites and the Guadalupe River diversions were simulated as monthly totals presented in Appendix B without adjustments for losses such as evaporation. This is consistent with previous investigations' observations that most of the water entering the recharge structures infiltrates rapidly. Even at the larger structures, flood water has been modeled by others to be held generally less than one month (HDR, et al., 1998). Percolation rates have been estimated at two to three feet per day at most sites. Where field testing has occurred, such as at Parkers Creek and Middle Verde Creek in Medina County, high

infiltrations rates have been confirmed (HDR, et al., 1998). One exception was the Lower Blanco site where previous studies corrected available volumes for evaporation due to limited infiltration rates (HDR, et al., 1993). Due to the uncertainties associated with holding times, no evaporative losses were assumed for this Phase III study. However, some small adjustments to the total volume of water available were based on preliminary facility sizing as discussed below.

The unappropriated and marketable estimates at diversion points along the Guadalupe River are not additive and cannot all be implemented without adjustment. For example, if unappropriated water is diverted near Comfort, the amount of unappropriated water at downstream diversion points would be less than current WAM estimates. As a conservative assumption, the total amount of any upstream diversion was subtracted from the amount available downstream when Guadalupe diversions were analyzed in combination.

6.2.2. UNUSED WITHDRAWAL PERMITS

As previously discussed in Chapter 5, an analysis of unused withdrawal rights indicated that averages of 51,215 AFY and 97,630 AFY might be available from the Uvalde Pool and the San Antonio Pool, respectively. These amounts were applied as enhanced recharge for model analysis. Although the average amounts may be expected to increase in wet times and decrease during dry times, recent data indicate that several long-term leases have been executed, making the water available under both wet and dry conditions. Further, the cumulative, long-term effects as indicated by the groundwater model are expected to be similar whether pumping is varied on an annual basis or an average amount of pumping is assumed each year. Additional considerations for modeling average unused permit amounts as recharge over time include:

- Total pumping never exceeds baseline conditions; other pumping is decreased by the amount of the unused permit pumping
- The average amounts of unused permit pumping are reduced by CPM rules during dry times
- Pumping occurs west of the springs to minimize impacts to springflow

6.3. SIZING OF RECHARGE STRUCTURES AND PIPELINES

For the purposes of preliminary costing, previous work on sizing of recharge structures and pipelines was reviewed and incorporated into this Phase III study. Previous facility sizes were compared to the updated amounts of source water for potential adjustment. The scope for the Phase III work did not include additional reservoir modeling to optimize recharge to the revised source water amounts, and the previous work was judged sufficient to encompass the appropriate size of the recharge structures and allow pipeline capacities to be estimated. The methodologies used to select recharge structure size and pipeline capacities for purposes of costing and analysis are discussed in the sections below.

6.3.1. SIZING OF RECHARGE STRUCTURES

Considerable work has been conducted by others on optimal sizing of a recharge structure for each of the Type 2 sites (HDR, et al., 1991, June 1994, 1998). Various recharge pool sizes and associated recharge potential (conservation capacities) have been identified for each site based on site topography, existing structures, and other factors. Reservoir modeling was conducted in these past studies that incorporated the amount of streamflow available for recharge and the various sizes of the recharge pool. This work involved a detailed examination of the amounts and timing of source water availability on a daily basis, incorporating reasonable, and in some cases field-tested, recharge rates (Vaugh, personal communication, 2008). From this analysis, rating curves were developed that illustrated the ability to capture and recharge large flood flows at most locations. Based on the rate curves and reservoir modeling, the optimal size of the recharge structure was selected for the available amount of water.

To allow our review of the amounts of recharge that could be accommodated in the previously-determined optimal size basins, HDR provided a file of monthly recharge amounts for the optimal-size Type 2 projects. These monthly volumes were compared to the volumes developed in the Phase III WAM model runs to identify structures where the WAM-revised recharge water was significantly different from the previous recharge amounts. Average amounts are summarized in Table 6-2.

Table 6-2: Comparison of Source Water for the Phase III Study to Previous Studies

Type 2 Recharge Sites	Average Annual Source Water	
	Phase III (1947-2000) AFY	Previous Studies* (1947-1989) AFY
Indian Creek	11,299	32,014
Lower Frio	264	21,427
Lower Sabinal	64	21,117
Lower Hondo	673	7,208
Lower Verde	300	6,397
San Geronimo	4,591	4,368
Cibolo	24,020	9,557
Lower Blanco	80,829	63,491

*Source: unpublished data files, HDR enhanced recharge amounts, optimal pool size (HDR, 2008)

As shown on the table above, the average amounts of source water available at the Type 2 sites as determined in the Phase III study differ significantly from previous totals. For sites in the Nueces River Basin (Indian Creek through Lower Verde), available source water totals are much lower in the Phase III study than previously estimated. Available water at San Geronimo is essentially unchanged from previous work. Water available at Cibolo and Lower Blanco are higher than previous estimates. A review of maximum monthly recharge amounts for the Phase III work and the HDR work indicated similar relationships.

These differences are likely attributable to the two different methodologies employed for source water development (i.e., application of the revised WAM in the Phase III study and daily reservoir modeling for the previous studies). The WAM application in the Phase III study was discussed in Chapter 5, detailing many of the conservative assumptions. Some of the most applicable differences between the WAM development of source water and previous estimates are summarized below:

- WAM runs account for all downstream rights including those associated with Choke Canyon/Lake Corpus Christi, which were not included in previous studies (SCTRWPG, 2006; Vaugh, personal communication, 2008)
- Baseline modifications to the WAM include lower springflow amounts for satisfying downstream uses; as such, less streamflow is available for recharge
- WAM construction is conservative by not accounting for return flows

The higher Phase III averages available for recharge at the Cibolo and Lower Blanco sites likely relate to sizing for optimal capture rather than 100 percent capture of available water (HDR, et al., 1998). Also, there may be limitations of recharging large volumes in a short duration at the two sites. In particular, high groundwater levels have been noted at the Lower Blanco site, which may result in rejection of recharge. Phase III groundwater modeling did not indicate significant rejection of recharge (indicated by the model water balance), but since recharge was incorporated into the model on a monthly basis, impacts of shorter duration may not be fully analyzed.

Given that Phase III amounts available for recharge are lower or equivalent to previous estimates at the Indian Creek, Lower Frio, Lower Sabinal, Lower Hondo, Lower Verde, and San Geronimo sites, optimal-size recharge structures appear more than capable of handling the revised amounts without significant reductions in available water. In addition, some sites could potentially be down-sized as a cost saving measure, given the significantly reduced volumes, especially at Lower Sabinal. Additional reservoir modeling may be needed for optimizing sites in the future; for this analysis, sites were not arbitrarily down-sized and the previously-determined optimal size is maintained in this study for costing purposes.

Since there are indications of more Phase III water available at the eastern Type 2 sites than was previously analyzed, the largest reservoir capacities were selected for costing. These capacities for Cibolo and Lower Blanco (50,000 AF each) are considered the maximum practical size for the two sites (HDR, et al., 1998). Assuming an infiltration rate of two to three feet per day, the capacities appear capable of handling the larger quantities of water available on a monthly basis, the time step of the WAM. Additional field studies and/or surface reservoir modeling will likely be needed in the future to re-evaluate the actual quantity of water that can be recharged at the capacities sized.

6.3.2. SIZING OF PIPELINES

Pipelines are included in several Phase III R&R components for transmitting source water to appropriate recharge sites. In general, pipelines are required for the Indian Creek pump-over to Dry Frio, the Lower Blanco pump-over to San Marcos FRS, diversions from the Guadalupe River to Type 2 structures, and transmitting groundwater to the recharge zone from new wellfields. In order to select pipeline sizes for costing purposes, this study incorporates previous analyses and considers revised amounts of water for conveyance.

For the two projects involving pump-overs, recommended sizing by HDR is used. The Lower Blanco project requires a 24-inch pipeline capable of transmitting up to about 1,000 AF/month, an amount determined by HDR capable of being recharged at the FRS. This size was used in this component for costing purposes (Appendix C). Because more water was available at Indian Creek than could be transmitted by a 24-inch pipeline, both the HDR-recommended size and a much larger pipeline capacity were evaluated for costs. The HDR pipeline was capable of transmitting about 2,000 AF/month. Given the maximum water available and the benefits associated with the pump-over, a pipeline capacity of 20,000 AF/month was also considered. Costs were developed for both sizes to allow for a better understanding of the cost differential.

For initial sizing of pipelines from potential Guadalupe River diversion points, the maximum amount of available water per month was considered. These locations, including Comfort, Canyon Lake, and Lake Dunlap represent relatively large amounts of unappropriated water. The first step was to select pipeline capacities that could maximize available water, recognizing that down-sizing may be appropriate in the future to minimize costs.

To evaluate potential amounts of water, histograms were made of the unappropriated water rights at three diversion points; Comfort, Canyon Lake, and Lake Dunlap. In addition, since unappropriated water on the Medina River could potentially be combined with the conveyance from near Comfort, this additional water source was included. The histograms are shown on Figures 6-2 and 6-3.

The histograms plot bracketed amounts of unappropriated water for the number of months that water is available over the groundwater model period (1947-2000). In order to view the maximum amount of water in detail, months when available water was less than 5,000 AF/month are not shown. The first bar graph represents monthly amounts from 5,000 AF/month to 10,000 AF/month. For example, the maximum monthly amount of water available at Lake Dunlap is between 370,000 AF/month and 380,000 AF/month as shown on Figure 6-2. This large quantity of water is available in only one month out of the total number of months for which unappropriated water was derived from the WAM (198 months). As such, it does not seem cost efficient to size the pipeline to capture the largest amount due its infrequent occurrence and difference between that amount and the next largest amount (i.e., 220,000 AF/month, again available during only one month, Figure 6-

2). In addition, management strategies for Guadalupe diversions are primarily beneficial for maintaining springflows and modeling has indicated that the peak flows are not as beneficial over time since they occur at a time when water levels are already relatively high.

Given these conditions, histograms for the R&R diversion points were reviewed and pipeline capacities were sized to capture most, but not all, of the available water. For diversions from Canyon Lake and Lake Dunlap, about 40,000 AF/month (about 600 cfs) was needed to capture most of the benefits of available water at Lake Dunlap (Figure 6-2). This flow was accommodated by assuming two 108-inch pipelines as provided in Appendix C (Table C-5, Element P-2 and P-3). Using a similar histogram analysis, 15,000 AF/month (about 250 cfs) of pipeline capacity was assumed at the Comfort diversion site, with an increase to 30,000 AF/month (about 500 cfs) for the Comfort plus Medina River water (Figure 6-3). Costs for these facilities assume the use of 72-inch pipelines with two pipelines accommodating the larger flows from Medina Lake and are provided in Appendix C (Table C-5, Elements P-6.1 and P-6.2). While it is recognized that these are large, expensive pipelines, an attempt was made not to arbitrarily limit the amount of water available for R&R components. Capacities can be down-sized in the future to minimize costs.

6.4. COMPONENT MODELING RESULTS

Incorporating the considerations and assumptions described in the preceding sections, the individual components on Table 6-1 were simulated with the EAA model. Simulation details and results are provided in the remaining sections of this Chapter.

6.4.1. ENHANCED RECHARGE AT TYPE 2 R&R SITES

Groundwater modeling was used to analyze benefits from recharge at the Type 2 sites individually and in combination (Components 1-20). Available monthly source water at the Type 2 sites from 1946-2000 was used in the analysis. Unappropriated estimates were used in the initial analysis. Estimates of marketable water were combined with the unappropriated amounts in additional runs to analyze a maximum available volume for each location. An additional analysis compared the difference between the revised source water estimates from the WAM to previously-used source water estimates by HDR.

ENHANCED RECHARGE AT INDIVIDUAL TYPE 2 SITES

Figure 6-4 shows the total available source water for all Type 2 R&R sites including unappropriated amounts and the sum of unappropriated and marketable water. The available water varies greatly from year to year and, at most locations, available water is sporadic. For example, at Indian Creek there is no available water for recharge 60 percent of the time (1946-2000), but in some years as much as 191,000 AF of water can be

available (1973). In 1987, the central sites (Lower Frio to Lower Verde) had large volumes of marketable water available for recharge, unlike any other year in the study period. This large amount of marketable water was repeated in 1998, as the last few years of available data for marketable water were simply repeated to estimate volumes for years without data. Lower Blanco represents a large portion of the total available water, an annual average 57 percent of all locations combined. Indian Creek, San Geronimo, and Cibolo also represent a large part of the recharge in some years.

Because these larger volumes are included, the scale on Figure 6-4 doesn't allow for easy visualization of the smaller amounts of available water at the other Type 2 sites. To allow a more detailed review of these data, available water is repeated on Figure 6-5 for the R&R sites from Lower Frio to Lower Verde. As shown on the figure, water is more consistently available at Lower Hondo, large amounts of water are only sporadically available at Lower Frio, and almost no water is available at Lower Sabinal after about 1950.

The monthly unappropriated water and the maximum available water (unappropriated plus marketable) were simulated at each location for both model halves. Water levels from the end of the first half of the simulation were used as the beginning water levels for the second half. Differences from the baseline water budget indicate the fate of the recharge water – i.e., whether the recharge was discharged at wells or springs or if water remained in aquifer storage. For the purposes of this discussion, the change to each of these water budget items is referred to as the yield for each component.

Figures 6-6 and 6-7 show the total amount of recharge applied at each Type 2 site and the corresponding yield for the maximum available source water and unappropriated water, respectively. For both figures, the top graph represents the recharge and yield for 1947-1973 and the bottom graph shows similar details for 1974-2000. Although Figure 6-6 represents a larger amount of recharge for sites with marketable water, the relative benefits to springflow, wells, and aquifer storage are similar for both figures. Graphs clearly indicate the larger available water in the eastern and western sites. In the west, a large amount of this enhanced recharge remains in the aquifer by end of the first half of the simulation (Indian Creek). In the east, almost all of the water recharged at Lower Blanco exits San Marcos Springs (included in Other Springs).

For the second half of the model time period (1974 to 2000), more water is available due to wetter hydrologic conditions, but relative contributions to springflow and wells are similar to the first model half for each respective sites. One exception is Indian Creek, where a larger percentage of recharge water would be discharged at springs during the second model half.

Figures 6-8 through 6-15 show the volume of enhanced recharge remaining in the aquifer at each Type 2 site for both unappropriated and maximum (unappropriated plus marketable) source water. The amount of recharge remaining in the aquifer is dependent on the timing and volume of available source water, the location of recharge, and

hydrologic conditions of the baseline model (the status of critical period). Longer aquifer retention and larger amounts of source water result in a lot of water being accumulated in the aquifer (475,000 AF for Indian Creek, maximum water, and 200,000 for Lower Frio, maximum water (Figures 6-8 and 6-9) at the end of the first model time period.

Three central sites, Lower Sabinal, Lower Hondo, and Lower Verde, have less source water available in the early part of the simulation; source water becomes available in some months at the end of the simulation (1987 and 1998) (Figures 6-10, 6-11, and 6-12) . Peaks near the end of the period indicated the potential availability of marketable water only. Lower Sabinal, in particular, has almost no unappropriated water available, and, as such, does not provide long-term benefits for aquifer storage (Figure 6-10).

More source water is generally available for sites in the GSA River Basin (Figures 6-13 through 6-15). Enhanced recharge applied at the San Geronimo site results in relatively short retention times, but as recharge is continually applied, storage increases consistently over the simulation. The source water available at Cibolo is more consistent and a higher volume than the central locations and thus the amount of recharge remaining in storage is also much higher (100,000 AF at the end of the simulation). Lower Blanco also has a higher volume of source water available. However, as the slug and annual recharge analyses confirm, recharge applied at Lower Blanco has a very limited retention time in the aquifer. The source water recharged at this location results in large peaks of recharge in storage that quickly decline.

ENHANCED RECHARGE AT ALL TYPE 2 SITES

Enhanced recharge with unappropriated water was simulated at all Type 2 sites in combination to evaluate regional effects. Consistent with the program in the regional water plan (L-18), pump-overs from Indian Creek to Dry Frio and from Lower Blanco to the San Marcos Flood Retention Structure (FRS) were included (SCTRWPG, 2006). For the pump-overs, 45 percent of Indian Creek unappropriated water was recharged at Dry Frio and 35 percent of Lower Blanco unappropriated water was recharged at FRS. These percentages are consistent with long-term average percentages used in previous evaluations (HDR, 2008). Total recharge for all Type 2 sites averaged 119,847 AFY.

The yields of enhanced recharge over the baseline simulation for each half of the model are shown on Figure 6-16. Consistent with previous presentations in this report, increased pumping (due to fewer critical period reductions) is shown in blue; increased springflow at Comal Springs and other springs are shown in green and gray, respectively; and the volume of recharge remaining in aquifer storage is shown in light blue.

In the first half of the model (1946-1973) the enhanced recharge increased pumping by a total of 172,644 AF (an average of 6,166 AFY) and increased springflow at Comal Springs by 228,042 AF (an average of 8,144 AFY). For the second half of the model (1974-2000), the enhanced recharge increased pumping over baseline by 279,380 AF (an average of

10,347 AFY) and increased springflow at Comal Springs by 622,534 AF (an average of 23,057 AFY). In the second half of the model, aquifer storage had decreased. The relative contribution to each water budget item is summarized on Table 6-3 as a percentage of total recharge.

Table 6-3: Yield as Percent of Enhanced Recharge at Type 2 Recharge Sites

Percent of Recharge Contributing to:	1946-1973	1974-2000	Overall
Pumping	6%	7%	7%
Comal Springs	9%	17%	14%
Other Springs	64%	81%	74%
Remaining in Storage	21%	-5%	5%

**Percentages for 1974-2000 are higher than 100 percent of recharge due to the carryover of water remaining in storage from the previous model period.*

As shown in the percentages above and illustrated on Figure 6-16, most of the recharge water is discharged from springs other than Comal Springs. This is especially true in the later time period, representative of wetter hydrologic conditions. The large volume is mainly flow to San Marcos from the unappropriated water recharge at Lower Blanco. In preliminary runs, 95 percent of annual enhanced recharge at Lower Blanco was estimated to contribute to San Marcos springflow. While maintaining springflow at San Marcos Springs is valuable, the flow at San Marcos Springs alone did not trigger a critical period stage in the baseline model. Flow at San Marcos was only below the critical period triggers (96 cfs and 80 cfs for stages 1 and 2, respectively) during time periods when Index Well J-17 or Comal Springs were also below the critical period triggers. Thus, increasing flow at San Marcos Springs yields limited benefit to the goals of maintaining springflow at Comal Springs or increasing water supply. In addition, the Cibolo Type 2 site located nearby contributes significantly to San Marcos Springs and can be used to maintain springflow at both San Marcos and Comal Springs.

Given the limited benefits from Lower Blanco recharge, the enhanced recharge program was simulated again with all sites except for Lower Blanco (and the associated pump-over to San Marcos FRS). This modification decreased the average recharge for the program to 40,498 AFY, 33 percent of the total recharge with Lower Blanco. The yield over the baseline simulation of the enhanced recharge from the L-18 component without Lower Blanco for each half of the model is shown on Figure 6-17. Table 6-4, below shows the yield of enhanced recharge for each half of the model and the total simulation.

Table 6-4: Yield as Percent of Enhanced Recharge at Type 2 Sites without the Lower Blanco Recharge Site

Percent of Recharge Water Contributing to:	1946-1973	1974-2000	Overall
Pumping	16%	25%	21%
Comal Springs	19%	42%	32%
Other Springs	15%	51%	35%
Remaining in Storage	50%	-18%	12%

*Percentages for 1974-2000 higher than 100 percent of recharge due to the carryover of water remaining in storage from the previous model period.

A comparison of Table 6-3 and 6-4 illustrates the main difference to Other Springs with and without Lower Blanco in the program. Without Lower Blanco, most of the recharge water contributes to pumping, storage, and Comal Springs, on a percentage basis. Table 6-5 compares the actual values contributing to each element with and without Lower Blanco recharge.

Table 6-5: Yield from Type 2 Enhanced Recharge Program with and without the Lower Blanco Recharge Site

Recharge Contribution to:	Enhanced Recharge Program (AFY)			Enhanced Recharge Program without Lower Blanco (AFY)		
	1946-1973	1974-2000	1946-2000	1946-1973	1974-2000	1946-2000
Total Recharge	96,063	149,304	122,200	35,791	46,934	41,261
Pumping	6,166	12,287	9,171	5,673	11,735	8,649
Comal Springs	8,585	24,982	16,635	6,931	19,789	13,243
Other Springs	61,271	121,571	90,873	5,440	23,885	14,495
Remaining in Aquifer	20,040	-9,536	5,521	17,746	-8,475	4,874

While the volume of total enhanced recharge of the recharge program without Lower Blanco is significantly less than the scenario including all sites, the effect of recharge on pumping and Comal Springflow was not significantly impacted. This limited reduction in benefits illustrates that the large volume of enhanced recharge to Lower Blanco has limited effect on water supply and Comal springflow.

HDR SOURCE WATER AT ALL TYPE 2 SITES

As previously discussed, the source water generated for the Type 2 sites using the WAM methodology produced much lower estimates of available water than had been used in

other evaluations. HDR provided unpublished data files of recharge amounts used in the previous analysis for a more detailed comparison (HDR, 2008). HDR recharge amounts were simulated with the modified EAA model and compared to baseline and the enhanced recharge program with the WAM source water amounts.

Table 6-6 compares the average available recharge between the WAM-derived unappropriated source water (WAM) and amounts used by HDR for the two model time periods. The HDR estimates are significantly larger than the estimates from the WAM for all sites in the Nueces basin. As previously explained, this difference may be attributable to the WAM incorporation of all downstream water rights. Only two sites, Lower Blanco and Cibolo, were estimated to have more water in the WAM estimates. This could be due to the HDR method taking into account reservoir capacity and percolation capacity.

Table 6-6: Average Enhanced Recharge Available at Type 2 Sites

Type 2 Recharge Sites	1946-1973 (AFY)		1974-2000 (AFY)	
	WAM	HDR	WAM	HDR
Indian Creek	8,013	11,353	4,119	13,638
Dry Frio	6,556	12,395	3,370	13,906
Lower Frio	221	11,606	298	22,881
Lower Sabinal	146	12,994	4	20,937
Lower Hondo	453	5,754	894	5,779
Lower Verde	348	3,407	268	6,890
San Geronimo	2,321	2,855	7,052	4,157
Cibolo	17,663	8,208	30,927	7,062
Lower Blanco	39,183	33,566	66,547	45,572
San Marcos FRS	21,099	10,381	35,833	12,320
Totals	96,003	112,519	149,312	153,142

Specific benefits of the enhanced recharge program with HDR recharge estimates are shown on Figure 6-18 for each half of the model. Because HDR recharge amounts are higher at the western and central recharge locations, simulation with these amounts yields a greater benefit to pumping and increased springflow at Comal Springs. Because the WAM-generated water is higher at the easternmost sites (Lower Blanco and Cibolo), the

simulation with the WAM source water shows more benefit to springs other than Comal Springs. Table 6-7 documents the differences between the two runs.

Table 6-7. Percent Difference between HDR Recharge and WAM-Generated Recharge at Type 2 Sites

Comparison of HDR Recharge Simulation to WAM Recharge Simulation			
Change with HDR Recharge to:	1946-1973	1974-2000	Overall
Recharge	17%	3%	8%
Pumping	285%	121%	177%
Comal	72%	22%	35%
Springs other than Comal	-23%	-23%	-23%
Remaining in Aquifer	35%	32%	38%

As shown in Table 6-7, the HDR recharge represents a 17 percent and 3 percent increase in recharge over the WAM estimates for the first and second half of the model, respectively. This increase in recharge results in a 177 percent overall increase in pumping over the WAM recharge simulation. Comal Springs increased an average of 35 percent in the HDR recharge simulation. Aquifer storage also increased for the HDR recharge simulation. The only benefit to the WAM recharge simulation was the resulting springflow at other springs, which was 23 percent lower in the HDR recharge simulation.

An additional model run was conducted using the HDR derived recharge estimates except for the Lower Blanco (and associated pump-over) recharge site. The specific benefits of this simulation are shown on Figure 6-19. Table 6-8 shows the percent difference in benefit between HDR recharge estimates and WAM generated estimates for this additional run.

Table 6-8: Percent Difference between HDR Recharge and WAM-Generated Recharge at Type 2 Sites without Lower Blanco

Comparison of HDR Recharge Simulation to WAM Recharge Simulation (without Lower Blanco)			
HDR Recharge increases to:	1946-1973	1974-2000	Overall
Recharge	99%	103%	101%
Pumping	341%	127%	199%
Comal	109%	33%	53%
Springs other than Comal	9%	66%	55%
Remaining in Storage	44%	44%	44%

When recharge associated with the Lower Blanco site is removed from the simulation, the amount of HDR recharge is double (increase of about 100 percent) the recharge for the WAM-generated simulation. As in the previous run, the simulation with the HDR recharge provided significantly greater benefits to water supply (pumping) and Comal Springs than did the simulation with the WAM recharge estimates. Even without the large amounts of WAM-generated recharge at Lower Blanco (and its associated contribution to San Marcos Springs), discharge at other springs increased an average of 55 percent from the WAM-generated recharge simulation.

These model runs demonstrate the large negative impacts that less source water has on the enhanced recharge projects. The lack of excess streamflow for enhanced recharge will make the other sources of water critically important to a successful R&R program.

6.4.2. ENHANCED RECHARGE WITH GUADALUPE (AND OTHER) RIVER DIVERSIONS

Several groundwater modeling runs were performed to analyze Components 22, 23, 24, 28 and 29. These components involve the diversion of surface water outside of the recharge zone and conveyance back to recharge sites. Potential source water diversion locations include three on the Guadalupe River (near Comfort, Canyon Lake, and Lake Dunlap), one on the tributary Comal River, and one on the Medina River, which flows into Medina Lake. General locations for these diversion sites are shown on Figure 6-1.

Diversion locations near Comfort and at Canyon Lake are north of the recharge zone and separated by a watershed divide. However, with relatively short pipelines, water could be pumped over to reach tributaries to recharge sites. For Canyon Lake, the pipeline would extend to Cibolo Creek, allowing the piped water to flow downstream and be captured by

the proposed Cibolo Dam. For the diversion near Comfort, water would be conveyed to the Medina River, and allowed to flow into Medina Lake, where it could be re-captured and conveyed to nearby Type 2 sites. An advantage to the Comfort diversion is that water could be combined with unappropriated water on the Medina River, allowing water from two sources to be conveyed together. A disadvantage of these northern sites is that excess springflow could not be captured for recirculation because sites are upstream of the springs.

The two remaining R&R diversion sites, Comal River and Lake Dunlap, are downstream of the springs and could be combined with excess springflow for conveyance to the recharge zone (Figure 6-1). The site on the Comal River is slightly closer to the recharge zone, but contains much less unappropriated water than potentially available at Lake Dunlap. In addition, diverted water further away from the springs may be more protective of springflow. Therefore, a component involving diverted streamflow at the Comal River site was not evaluated separately in this analysis. The type of benefits expected from the Comal River site would be similar to the Lake Dunlap component, except that the overall yield would be significantly less.

Two potential components involve the unappropriated water from Comfort and the Medina River; one component examines applying the enhanced recharge at the R&R sites at Lower Hondo and Lower Verde and one examines using the R&R site at San Geronimo. In the Verde and Hondo component, it was assumed the source water was divided equally between these sites. The diverted water from the Guadalupe River was supplemented by additional unappropriated water available on the local stream at the Type 2 sites.

For modeling purposes, the available source water for the San Geronimo site was reduced somewhat due to preliminary sizing of a pipeline sufficient to capture most, but not 100 percent, of the water (Figure 6-3). A pipeline capable of transporting 15,000 AF/month was assumed from Comfort to Medina diversion points and a pipeline of 30,000 AF/month was assumed from downstream of Medina Lake to the R&R site. No such constraint was made for recharge at the Lower Verde and Lower Hondo sites. Because of this, the average annual recharge to the Lower Verde and Lower Hondo sites was 63,798 AFY, greater than the average annual recharge to the San Geronimo site (49,299 AFY). However, both components had similar volumes of available water during drought conditions (5,302 AFY and 5,044 AFY for the Lower Verde/Lower Hondo and San Geronimo, respectively).

Table 6-9 shows the benefits, over baseline, for the entire model period (1946-2000). Data are presented both as total volume of enhanced recharge and as percent of enhanced recharge.

Table 6-9: Comparison of Yield between Lower Verde/Lower Hondo and San Geronimo Recharge Sites for Comfort/Medina Source Water

Enhanced Recharge Contributing to:	1946-2000			
	Average Volume (AFY)		Percent of Recharge	
	Comfort and Medina to LV and LH	Comfort and Medina to San Geronimo	Comfort and Medina to LV and LH	Comfort and Medina to San Geronimo
Comal Springs	22,250	19,368	35%	39%
Other Springs	12,339	8,373	19%	17%
Pumping	21,411	18,352	34%	37%
Remaining in Aquifer	7,798	3,206	12%	7%

As shown in the above table, the added source water from the Comfort and Medina diversion sites increases benefits to the aquifer over baseline by about 20,000 AFY for pumping and springflow for both recharge sites. The total recharge for the Lower Verde/Lower Hondo run was higher because the recharge associated with the Type 2 recharge sites was also included with the Comfort/Medina recharge. While the volume of enhanced recharge applied to the San Geronimo R&R site was slightly lower, the percent of enhanced recharge benefiting both Comal Springs and pumping was greater. Both components benefit aquifer storage (as indicated by remaining in the aquifer). Given the greater percentage of recharge to Comal Springs and pumping, the proximity of San Geronimo to Medina Lake, and the reduced cost of using only one R&R site, the San Geronimo R&R site appears to be the preferred alternative.

Dunlap diversions were also evaluated to select the most effective location for recharge. The unappropriated water at Dunlap was evaluated for conveyance to either San Geronimo or Cibolo recharge sites. Two model runs were prepared adding unappropriated water at Dunlap to each location, in addition to local available water at each site. For these evaluations, diversions at Dunlap were not constrained by pipeline size nor were diversions at upstream points considered. The simulation represents the maximum water available. For R&R scenarios presented in Chapter 7, the Dunlap unappropriated water was reduced based on pipeline capacity and use of upstream water.

Table 6-10 shows the benefit, over baseline, for the entire model period (1946-2000) as total volumes of water and percent of enhanced recharge.

Table 6-10. Comparison of Benefits between Cibolo Recharge Site and San Geronimo Recharge Site for Dunlap Source Water

Enhanced Recharge Contributing to:	1946-2000			
	Average Volume (AFY)		Percent of Recharge	
	Dunlap to Cibolo	Dunlap to San Geronimo	Dunlap to Cibolo	Dunlap to San Geronimo
Comal Springs	43,489	32,869	40%	41%
Other Springs	43,349	18,609	40%	23%
Pumping	15,165	22,269	14%	28%
Remaining in Aquifer	6,249	6,093	6%	8%

As shown above, the Cibolo R&R site is associated with more unappropriated water than at the San Geronimo Type 2 site and, as such, has a greater average annual benefit to springflow. However, in spite of the smaller volume of enhanced recharge, San Geronimo has a greater benefit to pumping due to its upgradient proximity to Index Well J-17 and other pumping wells. The two locations show a similar portion of recharge benefiting Comal Springs (40 percent of total recharge). Other springs (primarily San Marcos Springs) benefit more from recharge at the Cibolo site.

Component 23 examines Guadalupe Diversions from Canyon Lake diversion site to Cibolo Type 2 recharge site. This component was compared with Component 24, where the diversion site is moved downstream to Lake Dunlap, to evaluate relative benefits. Source water at both Canyon Lake and Lake Dunlap diversion sites are associated with similar amounts of unappropriated water. In addition, simulations also included the site-specific unappropriated water estimated for the Cibolo Type 2 recharge site. On average, available water for recharge for the Canyon Lake and Lake Dunlap components was 105,081 AFY and 108,252 AFY respectively.

Table 6-11 shows the benefits to various water balance items, over baseline, for the entire model period (1946-2000). Data are presented as both the volume of enhanced recharge and as a percent of enhanced recharge. Since the source water and recharge site were so similar for both components, benefits are also similar.

Table 6-11. Comparison of Benefits between Canyon Lake and Lake Dunlap Diversion Sites to Cibolo Type 2 Recharge Site

1946 - 2000				
Enhanced Recharge Contributing to:	Average Volume (AFY)		Percent of Recharge	
	Canyon to Cibolo	Dunlap to Cibolo	Canyon to Cibolo	Dunlap to Cibolo
Comal	43,816	43,489	42%	40%
Other Springs	40,577	43,349	39%	40%
Pumping	14,861	15,165	14%	14%
Remaining in Aquifer	5,827	6,249	6%	6%

6.4.3. RECIRCULATION OF EXCESS SPRINGFLOW

Component 21 evaluates benefits associated with excess springflow, previously-defined by the additional flow at Comal Springs (over the baseline scenario) resulting from enhanced recharge. The excess springflow was calculated on a monthly basis from the simulation of the Type 2 recharge sites (using WAM-generated source water). This excess springflow was added to the combined enhanced recharge at the Type 2 recharge sites as an additional source of water at the Cibolo Type 2 site.

Figure 6-20 shows the total amount of enhanced recharge water used in the simulation. The lower (yellow) portion of the bars representing the WAM-generated unappropriated water at the Type 2 recharge sites; the upper portion of the bars (green) shows the volume of excess springflow as generated by previous enhanced recharge simulations. The Cibolo Dam Type 2 recharge site was selected to receive the excess springflow as it is the most effective location for maintaining flow at Comal Springs (based on the preliminary model runs described in Chapter 4). The amount of excess springflow per month ranges from 0 AF/month to 92,248 AF/month, with an average of 14,109 AF/month. While the model can tabulate the amount of excess springflow due to a given recharge scenario, estimating actual excess springflow would require a detailed hydrologic analysis. Maximizing the capture of excess springflow as a source for recharge may prove difficult on a real-time basis.

To better understand the continuing effect of the enhanced recharge program as hydrologic cycles transition into another drought, a third section of the model was created. This section follows the second half of the model (1974-2000) and repeats the natural recharge simulated in the first half of the model (1947-1973). For display purposes, the third section of the model is often labeled as 2001-2027, but the recharge does not reflect any data or projections of hydrologic conditions during those years.

The excess springflow capture component was simulated with the three model sections and compared to both baseline and the enhanced recharge program without recirculation. Figure 6-21 shows the total yield of the enhanced recharge including recirculation. Table 6-12 presents the data on which Figure 6-21 was based.

Table 6-12: Yield for Enhanced Recharge and Excess Springflow Recirculation and the Percent Difference

Enhanced Recharge at Type 2 Sites (AFY)					
	Recharge	Pumping	Comal Springs	Springs Other than Comal	Remaining in Aquifer
1947-1973	99,621	6,394	8,903	63,541	20,782
1974-2000	248,925	18,682	32,130	186,867	11,246
2001-2027	94,909	7,887	10,721	64,275	23,273
Enhanced Recharge at Type 2 Sites with Excess Springflow Recirculation (AFY)					
	Recharge	Pumping	Comal Springs	Springs Other than Comal	Remaining in Aquifer
1947-1973	108,652	7,045	12,250	66,377	22,980
1974-2000	281,254	20,824	44,849	199,002	16,579
2001-2027	105,760	8,997	15,414	68,613	29,314
Percent Change* as a Result of Recirculation (%)					
	Recharge	Pumping	Comal Springs	Springs Other than Comal	Remaining in Aquifer
1947-1973	9%	10%	38%	4%	11%
1974-2000	13%	11%	40%	6%	47%
2001-2027	11%	14%	44%	7%	26%

*Percentages for model sections 2 and 3 may be higher than 100 percent of recharge due to the carryover of water remaining in storage from the previous model period.

Note: Excess springflow recirculated to Cibolo Type 2 Recharge Site

Recirculating the excess springflow increases the enhanced recharge and other water balance items. Recharge was increased by 9 percent to 13 percent for the three model sections. This increase in recharge increased the pumping yield by 10 percent to 14 percent, with slightly higher benefits on a percentage basis in the third section of the model. Increases to springflow at Comal Springs were significant, given that the excess springflow was recirculated to the nearby Cibolo Dam recharge site. Comal Springs flow increased 38 percent to 44 percent for the three model sections. Benefits were most pronounced during the third model section demonstrating the long-term advantages for aquifer management.

6.4.4. ENHANCED RECHARGE USING GROUNDWATER FROM UNUSED PERMITS

Model simulations were conducted to analyze potential benefits for applying the unused Edwards Aquifer withdrawal permits as enhanced recharge. Locations for two new wellfields were set up in the model, one for each pool (Uvalde Pool and San Antonio Pool). Since the baseline model simulates all pumping permits as fully used at all times, the well package had to be modified for these simulations. In the model, pumping in each pool was reduced by the volume of unused permits (on a county basis) and the unused permits are pumped in the model at the designated wellfields¹¹. Preliminary wellfield locations are shown on Figure 6-1. Unused permits were simulated to be recharged the same month they were pumped from the aquifer.

For the Uvalde Pool (Component 25), the unused permits were pumped from an Uvalde wellfield and recharged in the Dry Frio River channel. For the San Antonio Pool, the unused permits were pumped at a Medina wellfield and recharged at the Seco Creek recharge site. For both pools, the total amount of unused permits (and the applied recharge) was reduced based on the CPM reductions for that pool as observed during the baseline model. It is assumed that the unused permits would be subject to the same CPM rules as other withdrawal permits.

Table 6-13 shows the fate of the additional recharge from the unused permits for the entire model period (1947-2000). Data are presented both as total volumes of water and percent of enhanced recharge. The Uvalde unused permits provide less benefit (as percent recharge) for Comal Springs and slightly less benefit to Permit pumping (as a percent of recharge) than the San Antonio Pool. As with other component model runs, benefits to pumping include the increased pumping allowed under EAA withdrawal permits because of less severe CPM stages (due to higher water levels). The model run does not allow pumping above the 572,000 AFY cap for this simulation. Also, consistent with previous runs, recharge at Dry Frio (Uvalde Pool) remains in storage longer before discharging at springs. This time delay could allow recharge applied during wet conditions to benefit the aquifer years later during dry conditions.

¹¹ These wellfields are also referred to later in the document as recirculation wellfields when they are used to recover a portion of enhanced recharge and convey that water back to the recharge zone (one possible method of recirculation). According to the definitions used in this report, pumping unused permits for recharge is not referred to as recirculation.

Table 6-13: Total Yield from Unused Permits

Yield of Unused Permits as Source for Enhanced Recharge				
Recharge Contribution to:	Average Volume (AFY)		Percent of Recharge	
	Uvalde Pool	San Antonio Pool	Uvalde Pool	San Antonio Pool
Comal Springs	9,541	24,861	22%	33%
Other Springs	9,826	15,864	23%	21%
Permit Pumping	13,725	28,459	32%	38%
Remaining in Aquifer	9,500	5,837	22%	8%

6.4.5. ENHANCED RECHARGE WITH TYPE 1 STRUCTURES

As previously discussed, a Type 1 structure captures and holds surface water upstream of the recharge zone. Releases can be controlled such that recharge is optimized and timed to coincide with management objectives. To simulate a Type 1 structure, the unused permits from the San Antonio Pool were assumed to be held and released to Seco Creek during critical periods. The location, capacity, and management of recharge releases from Type 1 structures will impact the effectiveness. Only one configuration was simulated for this study; however, there are a myriad of possible management scenarios that could be used to optimize for specific objectives. For modeling purposes, it was assumed that a Type 1 structure located above Seco Creek had a maximum capacity of 100,000 AF¹². Water was released from the Type 1 structure based on the critical period stage simulated in the baseline model. For stages 1 through 3, 6,000AFY was released and recharged at the Seco Creek recharge site. In stage 4, 8,000 AFY was released and recharged. If the reservoir was full (100,000 AF), the full unused permit volume was released and recharged.

Table 6-14 shows the benefits, over baseline, for this Type 1 simulation. Results from the Type 1 simulation are compared with the Type 2 site analysis previously conducted for the Seco Creek recharge site. The Type 1 structure shows slightly less recharge as the Type 1 reservoir still contained available water that was not recharged at the end of the model. The similar volumes of recharge at the same location resulted in a similar overall yield to the basin.

¹² Preliminary sizing of a Type 1 at Seco Creek by others indicated that this specific site could not hold 100,000 AF and had a maximum capacity of about 23,000 AF (HDR, et. al., 1991). The Phase III simulation was conducted to conceptually evaluate the potential benefits of a Type 1 structure and the size limitations were ignored for the purposes of this analysis. If Type 1 benefits justify such a structure, then additional locations with larger capacities can be evaluated in the future.

Table 6-14: Comparison of Yield from Recharge in a Type 1 Recharge Structure (timed release) and a Type 2 Recharge Structure (recharged as available)

Recharge Contribution to:	Average Volume (AFY)*		Percent of Recharge	
	Type 1 Analysis	Type 2 Analysis	Type 1 Analysis	Type 2 Analysis
Comal Springs	9,541	24,861	22%	33%
Other Springs	9,826	15,864	23%	21%
Pumping	13,725	28,459	32%	38%
Remaining in Aquifer	9,500	5,837	22%	8%

*Source water for the enhanced recharge was the unused Edwards withdrawal permits pumped from the Medina recirculation wellfield as discussed previously.

Table 6-15 shows a comparison of Type 1 and Type 2 recharge on Comal Springs. The unused permit water applied at the Type 1 site resulted in slightly better conditions than Type 2 recharge with respect to Comal Springs. Even though recharge occurred in western Medina County, the timing of the Type 1 recharge prevented Comal Springs from going dry for two additional months; a comparative analysis with Type 2 conditions resulted in no flow for eight months. The benefits occurred during dry conditions; during wet and average conditions, springflow for both the Type 1 and Type 2 analyses was similar.

Table 6-15: Comal Springs Comparison of Type 1 and Type 2 Recharge

Comparison of Type 1 to Type 2 Recharge at Comal Springs		
	Type 1	Type 2
Minimum (cfs)	0	0
Maximum (cfs)	442	446
Average (cfs)	220	221
Months at 0 cfs	6	8
Months >40 cfs	631	630
Months >150 cfs	525	523
Months >225 cfs	323	325

Source water is unused Edwards permits pumped from the Medina wellfield

6.5. COMPONENT EVALUATIONS SUMMARY AND COSTS

The preceding evaluations of these 29 components provide the building blocks for developing an R&R program. Using the individual analyses, components can be combined to optimize a program for specific goals and objectives. A summary of the component analysis, along with yield and costs, is provided on Table 6-16.

The enhanced recharge and yield for average and drought conditions are summarized on Table 6-16 for component comparisons. The yield is represented as increases to permit pumping, Comal Springs flow, and aquifer storage. Benefits to other springs are not included. These yields represent the output from the modeling runs previously described and allow relative comparisons among components. However, it should be noted that runs have not yet been optimized for yield. For example, no pumping for recharge recovery has been incorporated.

Costs for each component were developed from the element costs provided in Appendix C. This costing approach provides modular costs, which can be easily combined for various R&R scenarios. For some components, costs may represent a pipeline or structure with a larger capacity than may be ultimately needed for an R&R program. Our approach was to first examine components that were capable of capturing a reasonable maximum of the available water while providing operational flexibility. Components can be down-sized in the future for potential cost savings if warranted.

To provide a relative cost scale to further evaluate each component, the annualized costs are divided by the yield (Table 6-16). Since the components have not yet been optimized for yield, the cost per AF does not necessarily reflect the actual benefit from any one component. Yet it does allow for cost comparisons among components.

Component combinations can provide either overlap and/or efficiencies. The aquifer response to various combinations is not always quantifiable and yields and costs are not necessarily additive. Yield and costs for some of the individual components are discussed in more detail below.

Table 6-16: R&R Components - Yield and Costs

Component		Recharge and Yield Average Conditions (1947-2000)				Recharge and Yield Drought Conditions (1947-1956)				Annual Costs	Annual Benefits - Average Conditions (Cost per AF)			
ID	Abbreviated Name for Model Simulation	Total Recharge (AFY)	Permit Pumping (AFY)	Comal Springs (AFY)	Remaining in Aquifer (AFY)	Drought Recharge (AFY)	Permit Pumping (AFY)	Comal Springs (AFY)	Remaining in Aquifer (AFY)	Annual Cost ¹ (\$)	Total Recharge (\$/AF)	Permit Pumping (\$/AF)	Comal Springs (\$/AF)	Pumping + Comal (\$/AF)
1	IC Type 2 Unappropriated ²	11,299	2,976	1,233	9,072	0	0	0	0	\$ 56,832,284	\$ 5,030	\$ 19,095	\$ 46,103	\$ 13,503
2	LF Type 2 Unappropriated	264	52	75	85	3	0	1	2	\$ 5,443,880	\$ 20,658	\$ 104,798	\$ 72,961	\$ 43,014
3	LS Type 2 Unappropriated	64	70	2	6	310	1	197	124	\$ 1,600,456	\$ 24,849	\$ 22,748	\$ 875,228	\$ 22,172
4	LH Type 2 Unappropriated	673	105	332	137	246	0	163	91	\$ 1,580,141	\$ 2,349	\$ 15,051	\$ 4,753	\$ 3,612
5	LV Type 2 Unappropriated	300	94	127	84	235	1	137	129	\$ 1,692,932	\$ 5,651	\$ 17,915	\$ 13,295	\$ 7,632
6	SG Type 2 Unappropriated	4,591	2,067	1,661	668	181	222	293	309	\$ 979,708	\$ 213	\$ 474	\$ 590	\$ 263
7	C Type 2 Unappropriated	24,020	3,587	10,292	4,137	3,767	769	2,165	1,581	\$ 4,107,688	\$ 171	\$ 1,145	\$ 399	\$ 296
8	LB Type 2 Unappropriated	80,829	442	2,514	2,297	10,965	378	293	5,502	\$ 9,018,341	\$ 112	\$ 20,412	\$ 3,588	\$ 3,051
9	IC Type 2 Maximum	24,083	8,897	4,776	24,529	2,147	55	108	1,755	\$ 56,832,284	\$ 2,360	\$ 6,388	\$ 11,899	\$ 4,156
10	LF Type 2 Maximum	9,820	2,987	1,995	4,934	4,421	1,491	714	2,373	\$ 5,443,880	\$ 554	\$ 1,823	\$ 2,728	\$ 1,093
11	LS Type 2 Maximum	3,224	1,882	1,618	1,254	683	81	409	228	\$ 1,600,456	\$ 496	\$ 851	\$ 989	\$ 457
12	LH Type 2 Maximum	2,997	1,677	1,784	1,246	480	4	348	204	\$ 1,580,141	\$ 527	\$ 942	\$ 886	\$ 457
13	LV Type 2 Maximum	1,120	594	691	644	330	0	233	196	\$ 1,692,932	\$ 1,512	\$ 2,850	\$ 2,450	\$ 1,317
14	SG Type 2 Maximum	4,807	4,260	3,436	1,423	322	223	413	355	\$ 979,708	\$ 204	\$ 230	\$ 285	\$ 127
15	C Type 2 Maximum	24,261	7,284	20,673	8,396	3,768	769	2,165	1,581	\$ 4,107,688	\$ 169	\$ 564	\$ 199	\$ 147
16	LB Type 2 Maximum	90,362	991	5,294	4,725	21,478	257	577	4,889	\$ 9,018,341	\$ 100	\$ 9,105	\$ 1,703	\$ 1,435
17	All L-18 WAM Unappropriated	122,200	8,219	16,635	6,473	15,679	1,946	2,808	-3,143	\$ 81,255,432	\$ 665	\$ 9,887	\$ 4,885	\$ 3,269
18	All L-18 HDR Available Water	132,496	25,405	22,529	14,106	49,245	3,921	5,416	13,968	\$ 81,255,432	\$ 613	\$ 3,198	\$ 3,607	\$ 1,695
19	L-18 (w/o LB) WAM Unappropriated	41,261	7,968	13,243	5,555	4,735	1,813	2,405	-1,338	\$ 72,237,090	\$ 1,751	\$ 9,066	\$ 5,455	\$ 3,406
20	L-18 (w/o LB) HDR Available Water	82,635	25,818	20,116	14,266	32,990	6,446	5,824	18,564	\$ 72,237,090	\$ 874	\$ 2,798	\$ 3,591	\$ 1,573
21	Excess Springflow (to Cibolo)	138,070	10,223	22,017	8,139	18,663	2,094	3,929	-2,617	\$ 184,004,972	\$ 1,333	\$ 17,999	\$ 8,358	\$ 5,707
22	Comfort and Medina to Hondo and Verde	63,798	21,411	22,250	7,798	5,302	3,406	3,120	-1,570	\$ 66,408,276	\$ 1,041	\$ 3,102	\$ 2,985	\$ 1,521
23	Canyon to Cibolo	105,081	14,861	43,816	5,827	7,782	2,393	4,179	-2,608	\$ 81,529,142	\$ 776	\$ 5,486	\$ 1,861	\$ 1,389
24	Dunlap to Cibolo	108,252	15,165	43,489	6,249	8,302	2,393	4,453	-2,549	\$ 106,857,228	\$ 987	\$ 7,046	\$ 2,457	\$ 1,822
25	Uvalde Unused Rights	42,419	13,725	9,541	9,500	37,514	3,339	6,287	26,455	\$ 22,699,730	\$ 535	\$ 1,654	\$ 2,379	\$ 976
26	Medina Unused Rights	75,021	28,459	24,861	5,837	61,887	9,758	28,515	23,615	\$ 52,394,806	\$ 698	\$ 1,841	\$ 2,107	\$ 983
27	Type 1	72,792	27,841	24,066	5,606	66,892	11,188	22,096	25,291	\$ 54,122,492	\$ 744	\$ 1,944	\$ 2,249	\$ 1,043
28	Comfort and Medina to San Geronimo	49,300	18,352	19,368	3,206	5,049	3,383	2,205	-1,509	\$ 64,114,911	\$ 1,301	\$ 3,494	\$ 3,310	\$ 1,700
29	Dunlap to San Geronimo	79,840	22,269	32,869	6,093	4,227	3,171	2,526	-1,665	\$ 312,703,268	\$ 3,917	\$ 14,042	\$ 9,514	\$ 5,671

¹Costs match the components included in each model simulation; see text for component description.

²Indian Creek cost contains a large pipeline to maximize recharge (Element P-10b in Appendix C). A smaller, less expensive pipeline (Element P-10a in Appendix C) was used for scenarios in Chapter 7.

6.5.1. COMPONENT YIELD

As shown on Table 6-16, yield for components 1 through 20 reflect the Type 2 recharge sites as stand-alone projects and as a combined project with various amounts of source water as previously described. Recharge and yield are much lower for the components using unappropriated water only, particularly during drought conditions. Regardless of the amount of water available for recharge, sites in the west result in most of the associated yield contributing to permit pumping and aquifer storage, while recharge at eastern sites primarily results in increases to Comal Springs.

For the Lower Blanco site (Components 8 and 16), the yield for permit pumping and Comal springflow is very low compared to the large amount of recharge. As previously explained, this is the result of rapid discharge from the aquifer at San Marcos Springs. For the combined Type 2 components using the WAM-generated unappropriated water for recharge, yield is generally unaffected by the exclusion of the Lower Blanco recharge site (compare Component 17 to Component 19). This occurs even though recharge is decreased by two-thirds.

Total available water available at the Guadalupe River diversion sites (Components 22 – 24, 28, and 29) is generally higher than any of the individual Type 2 sites. For components that divert water to the Cibolo recharge site (Components 23 and 24), most of the yield is seen at Comal Springs. As seen with the Type 2 analysis, recharge sites further west result in permit pumping increases (Components 22, 28, and 29). Although yields are similar for the Canyon diversion to Cibolo (Component 23) and the Dunlap diversion to Cibolo (Component 24), the Dunlap diversion has the added benefit of transmitting excess springflow.

The average amount of water available from unused withdrawal permits (Components 24 and 25) also represents a significant potential source of water for recharge producing yield to both permit pumping and Comal Springs.

6.5.2. COMPONENT COSTS

Costs were developed using Region L costing procedures. Methods, assumptions, and costs for specific elements associated with the components are provided in Appendix C (Tables C-4, C-7, and C-8). Annual costs associated with each component were extracted from Appendix C and summarized on Table 6-16. Costs include all itemized costs associated with the component evaluated. For example, the Dunlap to Cibolo (Component 24) costs include not only the proposed pipeline from Lake Dunlap to the Cibolo recharge site, but also the construction of the Cibolo Dam Type 2 structure (at an increased capacity from previous evaluations).

Costs vary widely for the Type 2 recharge sites (Components 1 – 20), but are generally less favorable for the western sites (Indian Creek, Lower Frio, and Lower Sabinal) on a cost per

AF basis. This is due to the low amounts of unappropriated water available at those sites (Components 1 – 3). Projects become more economical if additional recharge water in excess of unappropriated amounts becomes available (Components 9 – 11). Lower Hondo and Lower Verde (Components 12 and 13) also represent high unit costs for the enhanced recharge program, but these sites may provide available recharge for additional sources of water.

Components involving pipelines from the Guadalupe River to the recharge zone (Components 21 through 24, 28, and 29) have the highest costs. These pipeline were sized to maximize the flows that could potentially be available. Down-sizing the pipelines may result in more cost-effective components.

Costs for pumping the unused permits include two new wellfields, manifolds, and conveyance to recharge sites. Water from the two wellfields is conveyed to Seco Creek and the Dry Frio River channel, two sites capable of recharging large quantities of water. It is assumed that this recharge can be accomplished with existing conditions at each site. If a Type 2 structure is required to optimize the recharge, then costs can be updated.

Costs for the Type 1 structure (Component 27) are conceptual and based on a relatively small structure on Seco Creek (Upper Seco). If a Type 1 structure is deemed beneficial for future inclusion in the R&R program, updating costs for a larger structure on another western drainage may be warranted.

6.5.3. COMBINING COMPONENTS INTO SCENARIOS

Our scope of work provided that the most promising R&R components would be combined into several scenarios and associated costs would then be developed. However, numerous potential regional or local aquifer management objectives can be defined, some of which may be competing. For example, if all of the additional pumping provided by a recharge program is needed for use, recirculation would not be necessary. If additional pumping is not needed during wet times, more water is available for recirculation. Our approach was to combine the most promising components into numerous scenarios to allow the examination of the range of possible regional benefits focusing on components associated with the larger amounts of source water, even if they were associated with a larger cost. Scenario development and cost considerations are described in Chapter 7.

7. RECHARGE AND RECIRCULATION SCENARIOS

Based on the simulations of the management components in Chapter 6, the most promising strategies were combined into R&R scenarios. These scenarios focus on increasing recharge to the aquifer for the benefit of water supply while increasing springflow above baseline conditions. In these scenarios, EAA ARSR rules were applied to allow for the re-capture of enhanced recharge under certain conditions. Several scenarios examine the effect of various triggers and operational components on the ability to capture or recirculate recharge.

There are hundreds of possible reasonable scenarios for combining various R&R strategies over time. Although our scope of work provided for only several scenarios, we developed seven scenarios to cover a broad range of combinations. Actual implementation of a regional R&R program will likely be contained within these bounds.

Each of the seven scenarios tests various triggers for springflow and pumping as summarized below:

- Scenarios 1 and 2 examine increases in water supply pumping (referred to herein as enhanced pumping) that could be supported through enhanced recharge for various springflow targets.
- Scenarios 3 and 4 add an element of recirculation to the enhanced pumping by pumping up to 10,000 AF/month when springflow is above 225 cfs and returning that portion to the recharge zone. Scenario 3 allows for recovery of non-recirculated water through enhanced pumping; Scenario 4 leaves that extra amount of water in the aquifer.
- Scenario 5 was developed to isolate the benefit of the recirculation portion of Scenario 4 by repeating the restrictions on enhanced pumping and removing the recirculation pumping.
- Scenario 6 also includes an element of recirculation, but accomplishes this by recirculating excess springflow in the Dunlap diversion pipeline back to the Lower Verde recharge site.
- Scenario 7 examines alternating recharge from Dunlap (with excess springflow) between the Cibolo recharge site and the Lower Verde recharge site. In addition, the scenario eliminates the western Type 2 recharge sites as a cost-saving measure.

The first six scenarios all involve essentially the same facilities and, although costs are one consideration, some scenarios contain some components that might not be cost effective alone, but are maintained here to analyze combined effects. The final scenario, Scenario 7, considers costs developed in Appendix C and provides some measures for optimizing R&R operations. Table 7-1 summarizes the recharge components and pumping/recirculation criteria for each scenario.

Table 7-1: Summary of R&R Scenarios

Scenario	Enhanced Recharge Components	Enhanced Pumping	Recirculation Pumping	Recirculation Springflow
1a	Type 2s (except Blanco), Dunlap/Comfort diversions, unused rights	NA	NA	NA
1b	Type 2s (except Blanco), Dunlap/Comfort diversions, unused rights	when Comal Springs >40cfs	NA	NA
2	Type 2s (except Blanco), Dunlap/Comfort diversions, unused rights	when Comal Springs >225 cfs	NA	NA
3	Type 2s (except Blanco), Dunlap/Comfort diversions, unused rights	when Comal Springs >40 cfs	when Comal Springs >225 cfs, up to 10,000 AF/month to Verde; excess to enhanced pumping	NA
4	Type 2s (except Blanco), Dunlap/Comfort diversions, unused rights	when Comal Springs >40 cfs and <225 cfs	when Comal Springs >225, up to 10,000 AF/month to Verde	NA
5	Type 2s (except Blanco), Dunlap/Comfort diversions, unused rights	when Comal Springs >40 cfs and <225 cfs	NA	NA
6	Type 2s (except Blanco), Dunlap/Comfort diversions, unused rights, springflow recirculation	when Comal Springs >40 cfs and <225 cfs	NA	Excess springflow to Verde
7	Type 2s (except IC, LF, LS), Dunlap/Comfort diversions, unused rights, springflow recirculation	when Comal Springs >40 cfs	NA	Excess springflow and Dunlap to Cibolo or Verde

Enhanced recharge component names and other information in Table 7-1 are abbreviated for space. The reader is referred to the text for a more complete description of each scenario.

7.1. SCENARIO 1

Scenario 1 examines the benefit of all major sources of recharge to maximize water supply while maintaining springflow above baseline conditions. The scenario quantifies the amount of recharge that can be recovered through increased pumping.

Sources for enhanced recharge for Scenario 1 are shown graphically on Figure 7-1 and include the following:

- unappropriated water at Type 2 recharge sites (except Lower Blanco)
- unappropriated water at Lake Dunlap for conveyance back to the Cibolo Dam recharge site for springflow maintenance
- unappropriated water on the Guadalupe River near Comfort and unappropriated water from the Medina River for conveyance to the San Geronimo Type 2 recharge site via Medina Lake
- unused withdrawal permits pumped back to the recharge zone from the Uvalde and Medina recirculation wellfields.

Figure 7-1 shows the available enhanced recharge for each of these sources by year. The Lower Blanco recharge site (and associated pump-over) was removed from the Type 2 recharge program because of uncertainties in sustaining long-term percolation rates at the site and the relatively small benefit to Comal Springs or Index Well J-17 as observed in previous model runs.

Other adjustments included the subtraction of the diverted water at Comfort from the amount of unappropriated water at Lake Dunlap. Because the Comfort diversion point is upstream of Lake Dunlap, it represents some of the same water determined to be available at the Dunlap diversion point; as such, available water at Lake Dunlap was lowered accordingly. In addition, unappropriated water from all of the Guadalupe diversion points was capped at a maximum amount based on the largest pipeline capacities evaluated for surface conveyance. For Dunlap, the maximum monthly diversion was 40,000 AF/month. For the pipeline from Comfort/Medina River diversions, the maximum was 15,000 AF/month from Comfort and 30,000 AF/month for the combined Comfort /Medina River totals transmitted to the San Geronimo recharge site.

Scenario 1 also included the average unused withdrawal permits from the Uvalde and San Antonio pools, reduced according to CPM rules when applicable. Water was simulated as pumped from new wellfields in Uvalde and Medina counties to recharge sites along the Dry Frio River and at Seco Creek, respectively.

This recharge program was simulated over the extended model period 1946-2027 and conducted in three parts, 1946-1973, 1974-2000, and 2001-2027. As previously discussed the third part of the model repeats the hydrologic conditions of the first part and was added to quantify the effects of long-term enhanced recharge during a second drought of record.

To evaluate the benefits of this recharge program on water supply, two simulations were conducted, referred to herein as Scenario 1a and Scenario 1b. The first simulation, Scenario 1a, included baseline pumping only and quantified the fate of the recharge water. The second simulation, Scenario 1b, allowed additional pumping for recovery of the enhanced

recharge (defined herein as enhanced pumping). For the purposes of modeling, the increased pumping was accomplished by adding new wells to the model, located near the new Medina wellfield but in separate model cells. For actual implementation, the enhanced pumping could occur at existing well locations as approved by an ARSR recovery permit in accordance with EAA rules (EAA, 2008). The amount of enhanced pumping was determined by an evaluation of recovery factors developed for each recharge location as described in the following section.

7.1.1. DEVELOPMENT OF RECOVERY FACTORS

The goal of the increased pumping was to capture the maximum amount of recharge without causing springflow or other aquifer pumping (i.e., by triggering critical period) to be worse than the baseline simulation. In order to meet these two goals, pumping was increased only during stress periods when Comal Springs was above 40 cfs in the baseline simulation and factors were developed to estimate the portion of enhanced recharge that could be recovered by wells.

The factors, referred to as recovery factors, were developed using the results of preliminary model runs where slugs of recharge were introduced separately at each recharge location (Section 4.1.1 and Figure 4-2). In those runs, the percent of recharge remaining in aquifer storage over time was evaluated. Enhanced recharge contributes initially to groundwater storage, but with time, storage decreases as spring discharge increases. Therefore, the net storage available for recovery decreases over time. Model runs indicated that recovery factors would vary with the location of recharge and the time delay between recharge and recovery. Using these data, recovery factors were developed for the various recharge sites, grouped by similar aquifer response in western, central, and eastern sites. Recovery factors are tabulated in Table 7-2 and shown graphically on Figure 7-2.

Table 7-2: Recovery Factors – Percent of Recoverable Recharge at Recharge Sites

Time Since Recharge Occurred (Years)	Recovery Factors			
	Western Recharge Sites	Central Recharge Sites	Eastern Recharge Sites	
	Indian Creek, Dry Frio, Lower Frio	Lower Sabinal, Lower Hondo, Lower Verde, Seco Creek	San Geronimo	Cibolo
0	97%	80%	54%	53%
1	87%	70%	44%	43%
2	67%	49%	26%	23%
3	56%	34%	19%	15%
4	52%	28%	16%	11%
5	48%	23%	14%	9%
6	45%	21%	13%	7%
7	42%	18%	12%	5%
8	40%	17%	11%	4%
9	37%	15%	10%	3%
10	36%	13%	10%	3%
11	33%	12%	11%	3%
12	32%	12%	10%	3%
13	30%	11%	10%	2%
14	26%	8%	7%	2%
15	25%	8%	7%	2%
16	24%	8%	7%	1%
17	23%	7%	7%	1%
18	22%	7%	7%	1%
19	21%	7%	7%	1%
20	20%	7%	7%	1%

In developing the factors, the percent of enhanced recharge remaining in the aquifer was recorded for each elapsed year; percentages were developed for each half of the model and averaged. Factors are continued for 20 years simply to account for all of the water in the modeling analysis. Factors beyond a few years are less certain.

Because the retention time and fate of enhanced recharge are similar at the western sites (Indian Creek, Lower Frio, and Dry Frio), the factors for Lower Frio were applied to all three sites. The central sites (Lower Sabinal, Seco Creek, Lower Hondo, and Lower Verde) also exhibit similar retention times and aquifer response, and as such, the factors from these four sites were averaged. Factors for San Geronimo and Cibolo were treated separately to reflect the different retention times and aquifer response associated with

recharge at each site. No factors were estimated for Lower Blanco since that site was excluded from Scenario 1 and since modeling indicated that there is little to no aquifer storage over a period of years for recharge applied at that site. The recovery factors were tested and adjusted slightly based on model response.

7.1.2. SCENARIO 1A (WITHOUT ENHANCED PUMPING)

Prior to incorporation of enhanced pumping, a model run was conducted that evaluated the fate of the enhanced recharge only. This initial run provided data on the target amounts of water that could be captured with enhanced pumping. The run also allowed for a better understanding as to the fate of the recharge water under baseline pumping. Benefits to baseline pumping occurred because the enhanced recharge of Scenario 1 lessened the time period of CPM withdrawal reductions.

The fate of Scenario 1a recharge is shown in Tables 7-3 and Table 7-4 as an annual yield and as a percent of total recharge, respectively. The total yield for each model section is presented graphically on Figure 7-3.

Table 7-3: Scenario 1a without Enhanced Pumping

Model Section	Portion of Enhanced Recharge Contributing to: (AFY)			
	Permit Pumping	Comal Springs	Other than Comal	Remaining in Aquifer
1947-1973	57,518	51,764	25,284	41,654
1974-2000	62,383	114,204	118,356	47,531
2001-2027	69,973	59,918	46,185	47,753

Table 7-4: Scenario 1a without Enhanced Pumping as Percent of Enhanced Recharge

Model Section	Portion of Enhanced Recharge Contributing to: (% of total recharge)			
	Permit Pumping	Comal Springs	Other than Comal	Remaining in Aquifer
1947-1973	33%	29%	14%	24%
1974-2000	21%	38%	39%	16%
2001-2027	40%	34%	26%	27%

**Percentages for model sections 2 and 3 may be higher than 100 percent of recharge due to the carryover of water remaining in storage from the previous model period.*

For the first part of the model, the benefit is divided almost evenly between the Comal Springs, Permit pumping (due to CPM stages), and aquifer storage. In the second part of the model, a greater percentage of recharge flows to the springs. The third part of the model shows an even distribution for all water budget items and contains a significant amount of

aquifer storage carried over from the previous model section. In this simulation Comal Springs did not flow for 3 months, compared with 30 months under baseline conditions.

7.1.3. SCENARIO 1B (WITH ENHANCED PUMPING)

For Scenario 1b, additional pumping for recovery was added in accordance with conditions developed from the initial simulation. This Enhanced pumping was calculated for each stress period by using the recovery factors, described above, and the recharge applied at various recharge sites.

If the Comal Springs baseline at any stress period was less than 40 cfs, enhanced pumping was deactivated in the model. Once springflow recovered above 40 cfs, enhanced pumping was reactivated and recovery continued as limited by the recovery factors, including recovery of recharge that occurred when springflow was below the 40 cfs trigger. Recovery of recharge applied to past stress periods was discounted by the appropriate factor based on the amount of time from recharge to pumping. In addition, enhanced pumping was capped at 100,000 AF/month to prevent pumping cells from becoming dry in the model.

Because most of the enhanced pumping recovered the recharge immediately after it was applied at the recharge site, results from this scenario likely represent a maximum amount of enhanced pumping that could be accomplished. The enhanced pumping was not subjected to CPM reductions in accordance with EAA recovery permit rules (EAA, 2008).

7.1.4. RESULTS OF SCENARIO 1B

The yield of Scenario 1 with enhanced pumping is shown as the annual yield and the yield as a percent of enhanced recharge on Tables 7-5 and 7-6, respectively. The total yield for each model section is presented graphically on Figure 7-4.

Table 7-5: Yield of Scenario 1b

Model Section	Portion of Enhanced Recharge Contributing to: (AFY)				
	Enhanced Pumping	Permit Pumping	Comal Springs	Springs Other than Comal	Remaining in Aquifer
1947-1973	122,840	3,398	5,787	17,848	26,329
1974-2000	204,794	6,429	30,548	58,989	26,389
2001-2027	127,136	10,015	9,655	26,286	29,521

Table 7-6: Yield of Scenario 1b as a Percent of Enhanced Recharge

Model Section	Portion of Enhanced Recharge Contributing to: (% of total recharge)				
	Enhanced Pumping	Permit Pumping	Comal Springs	Springs Other than Comal	Remaining in Aquifer
1947-1973	70%	2%	3%	10%	15%
1974-2000	68%	2%	10%	20%	9%
2001-2027	72%	6%	5%	15%	17%

*Percentages for model sections 2 and 3 maybe higher than 100 percent of recharge due to the carryover of water remaining in storage from the previous model period.

In the simulation, the enhanced pumping was capable of recovering an average of 122,840 AFY to 204,794 AFY over the time period of each model section. The third section of the model showed improvement over the first section of the model, demonstrating the long-term accumulation of recharge water during wet time periods. Enhanced pumping represented a recovery of about 70 percent of the total enhanced recharge. At this capture rate, other pumping in the aquifer still remains slightly above baseline conditions. The enhanced pumping is shown by the red color on the bar graphs on Figure 7-4.

Comal Springs flow under baseline conditions and Scenario 1b is also shown on Figure 7-4. Throughout Scenario 1b, Comal Springs flow is generally above baseline, except for a few isolated occurrences when springflow declined. During the drought of record, Comal Springs was flowing for 14 more months in Scenario 1 than under baseline conditions. Overall springflow increased an average of between 3 percent and 10 percent as indicated in Table 7-6 above.

The few months when the springs fall below baseline are most likely the result of pre-determining the time periods when the springflow trigger of 40 cfs would occur. This use of a static rather than a real-time trigger in the model allowed enhanced pumping to occasionally continue beyond the trigger level. If a real-time trigger was used, pumping could be quickly stopped whenever the springs dropped below 40 cfs. However, due to the complexity of incorporating a real-time trigger into the groundwater model, it was assumed that the static trigger was a close approximation. The main benefit of Scenario 1b is the demonstrated ability to capture the recharged water through enhanced pumping. This water could be recirculated to the recharge zone or used directly.

7.2. SCENARIO 2

This scenario builds on Scenario 1 and allows the examination of using a different trigger for enhanced pumping and maximum protection of Permit pumping.

7.2.1. DESCRIPTION

Scenario 2 uses the same recharge program as Scenario 1 (Figure 7-1) and also focuses on benefits to water supply while maintaining springflow above baseline conditions. The scenario limits enhanced pumping to time periods when Comal springflow is above 225 cfs, the trigger for Stage 1 of CPM reductions. This was evaluated to prevent the permitted aquifer pumping from falling below baseline levels as was allowed in Scenario 1. The same recharge and recovery factors described in Scenario 1 were applied to Scenario 2.

Enhanced pumping was calculated per stress period by using the recovery factors for the recharge sites, similar to the simulation for Scenario 1. If the baseline simulation showed Comal Springs was less than 225 cfs, enhanced pumping was deactivated for that time period. When enhanced pumping resumed, recharge from past stress periods were still available for capture, subject to constraints by the recovery factors and time since recharge occurred. As with Scenario 1, enhanced pumping was capped at 100,000 AF/month to prevent pumping cells from becoming dry in the model and to create a reasonable limit on aquifer withdrawals in a single month.

7.2.2. RESULTS OF SCENARIO 2

The yield of Scenario 2 is shown as the annual yield (AFY) and the yield as a percent of enhanced recharge on Tables 7-7 and 7-8, respectively. The total yield for each model section is also presented graphically on Figure 7-5.

Table 7-7: Yield of Scenario 2

Model Section	Portion of Enhanced Recharge Contributing to: (AFY)				
	Enhanced Pumping	Permit Pumping	Comal Springs	Springs Other than Comal	Remaining in Aquifer
1947-1973	42,374	41,662	38,910	21,573	31,701
1974-2000	169,391	25,305	41,318	65,290	31,217
2001-2027	53,534	46,998	40,376	33,416	33,180

Table 7-8: Yield of Scenario 2 as a Percent of Enhanced Recharge

Model Section	Portion of Enhanced Recharge Contributing to: (% of total recharge)				
	Enhanced Pumping	Permit Pumping	Comal Springs	Springs Other than Comal	Remaining in Aquifer
1947-1973	24%	24%	22%	12%	18%
1974-2000	56%	8%	14%	22%	10%
2001-2027	30%	27%	23%	19%	19%

Percentages for model sections 2 and 3 may be higher than 100 percent of recharge due to the carryover of water remaining in storage from the previous model period.

The total enhanced recharge that was captured by enhanced pumping ranged from 42,374 AFY to 169,391 AFY, in dry and wet sections of the model, respectively. This is equivalent to 24 to 56 percent of enhanced recharge, a much lower recovery rate than in Scenario 1. However, the scenario also increased the amount of Permit pumping; increases of up to 27 percent over baseline pumping were observed during the dry conditions of the first model section. This results in a benefit to water supply of more than 48 percent in the first model section, 64 percent in the second section, and 47 percent in the third section.

While the capture rate is lower than the 70 percent recovery in Scenario 1, Scenario 2 is more protective of the springs. Throughout Scenario 2, Comal Springs is generally above baseline, as shown on Figure 7-5. As in Scenario 1, the likely cause of the negative impact during a few stress periods is the use of a static trigger generated from the baseline scenario. These spikes could likely be avoided with a real-time trigger. In Scenario 2, Comal Springs was prevented from going dry during the drought of record. The main benefit of Scenario 2 is the ability to capture a portion of the recharged water while protecting springflow and Permit pumping.

7.3. SCENARIO 3

This scenario builds on Scenarios 1 and 2 and adds the concept of recirculation pumping. When Comal Springs flow is above 225 cfs, there may be less demand for enhanced pumping and more opportunity for recovering a portion of enhanced recharge back to the recharge zone. For this scenario, recirculation is accomplished through pumping at the previously-simulated Medina wellfield and up to 10,000 AF/month is subtracted from the amount that would have occurred through enhanced pumping and is recirculated back to the recharge zone.

7.3.1. DESCRIPTION

Scenario 3 examines the benefit of recirculation, using a portion of the recharge captured by pumping as additional recharge to the model. The base recharge from Scenario 1 was

used for estimating preliminary amounts available for recirculation (Figure 7-1). Scenario 3 also used the same trigger and cap for the enhanced pumping, 40 cfs and 100,000 AF/month, respectively, as applied in Scenario 1. Because recirculation was accomplished with a hypothetical new wellfield, pumping was limited to 10,000 AF/month, judged to be a reasonable wellfield size for modeling purposes (approximately 30 wells at 2,500 gpm).

For Scenario 3, when Comal Springs was above 225 cfs, 10,000 AF/month was transported from a hypothetical wellfield in Medina County (near the unused permit wellfield in the model) to the Lower Verde Type 2 recharge site. The volume of water that could be transported to the recharge site was limited based on reasonable pipeline and wellfield capacity evaluated for the unused permit wellfield component. Any additional water that could be pumped during this month was assumed to be used directly and was included in the enhanced pumping volume.

The result was an additional source of recharge to that used in Scenario 1; the recharge used in Scenario 3 is shown on Figure 7-6 with the amount of water pumped for recirculation shown on the top of each bar. Figure 7-7 shows the total volume of enhanced pumping and pumping for recirculation. During dry conditions (springflow below 40 cfs), little to no water is assumed to be available for recirculation. However, more water could be available for recirculation if infrastructure allowed and enhanced pumping was decreased.

Enhanced pumping was calculated per stress period using the recovery factors, described in Section 7.1.1 above, which are linked to recharge sites in four geographic locations. If the baseline simulation showed Comal Springs was less than 40 cfs, no enhanced pumping occurred. As in previous scenarios, if no enhanced pumping occurred in previous stress periods and springflow was greater than 40 cfs, enhanced pumping was allowed to recover recharge from past stress periods, limited by the recovery factors. In addition, enhanced pumping was capped at 100,000 AF/month to prevent pumping cells from becoming dry in the model and to create a reasonable limit for additional monthly pumping. When Comal Springs was over 225 cfs, up to 10,000 AF/month was added as recharge in the next stress period (the next month).

7.3.2. RESULTS OF SCENARIO 3

The yield of Scenario 3 is shown as the annual yield and the yield as a percent of enhanced recharge on Tables 7-9 and 7-10, respectively. The total yield for each model section is shown on Figure 7-8.

Table 7-9. Yield of Scenario 3 with Enhanced Pumping and Recirculation Pumping

Model Section	Portion of Enhanced Recharge Contributing to: (AFY)					
	Enhanced Pumping	Permit Pumping	Recirculation Pumping	Comal Springs	Other Springs	Remaining in Aquifer
1947-1973	116,741	4,013	17,015	9,033	15,831	30,173
1974-2000	186,836	13,156	66,119	35,205	62,437	33,729
2001-2027	120,328	13,687	19,707	13,399	27,785	34,460

Table 7-10. Yield of Scenario 3 as a Percent of Enhanced Recharge

Model Section	Portion of Enhanced Recharge Contributing to: (% of total recharge)					
	Enhanced Pumping	Permit Pumping	Recirculation Pumping	Comal Springs	Other Springs	Remaining in Aquifer
1947-1973	61%	2%	9%	5%	8%	16%
1974-2000	51%	4%	18%	10%	17%	9%
2001-2027	62%	7%	10%	7%	14%	18%

Percentages for model sections 2 and 3 maybe higher than 100 percent of recharge due to the carryover of water remaining in storage from the previous model period.

As indicated by the tables above and Figure 7-8, this scenario benefitted water supply by allowing pumping to increase to more than 115,000 AFY for all model sections. The amount of increase for water supply was substantial. Benefits to Comal Springs were also noted for this scenario, with an increase in Comal Springs flow of 5 percent to 10 percent. The increase from 5 percent in the first model section to 7 percent for the third model section demonstrates the carryover benefits from enhanced recharge during the second model period.

To assess the general benefit of recirculation, Scenario 3 can be compared to Scenario 1. Both scenarios begin with the same recharge regime and allow pumping for recharge recovery above the same trigger, 40 cfs. The recirculation added approximately 16,000 AFY to 66,000 AFY of additional recharge in dry and wet times, respectively. While Scenario 3 had more recharge, the total recovered was actually lower than Scenario 1, both as a percent of total recharge and volumes. The total enhanced recharge that was captured by enhanced pumping ranged from 61 to 51 percent, in dry and wet sections of the model respectively. This is lower than the simulated capture in Scenario 1 of approximately 70 percent. The net enhanced pumping that could be available for direct use in Scenario 3 was 117,000 AFY and 187,000 AFY in dry and wet times. This is approximately 6,000 AFY and 18,000 AFY less than Scenario 1 in the same dry and wet times. In Scenario 3, Permit pumping saw an average benefit of 10,000 AFY, compared with an average benefit of 6,600 AFY in Scenario 1.

The benefit from recirculation was also exhibited in the increase in springflow as shown on Figure 7-8. Throughout Scenario 3, Comal Springs is generally above baseline and similar to Scenario 1 (but slightly higher). Due to the increased recharge, the simulated Comal Springs flow was higher in Scenario 3 than in Scenario 1 over 72 percent of the time, by an average of 5 cfs. The benefit to Comal Springs was seen mainly in the second section of the model, when most of the recirculation occurred. The total benefit to Comal Springs from Scenario 3 was 19,000 AFY over baseline, compared with 15,000 AFY in Scenario 1 in the second section of the model.

7.4. SCENARIO 4

Scenario 4 builds on Scenario 3 with the only difference being the limit to enhanced pumping. When springflow is over 225 cfs, it is assumed that enhanced pumping (pumping for recovery) is not needed and that water is available for recirculation to a recharge site. As in Scenario 3, up to 10,000 AF/month is recirculated, but unlike Scenario 3, any remaining available water is not dedicated to enhanced pumping and is allowed to remain in the aquifer.

7.4.1. DESCRIPTION

Scenario 4 also examines the benefit of recirculation by pumping a portion of the enhanced recharge back to the recharge zone, which functions as additional recharge in the model. Again, the recharge from Scenario 1 was used as the base and interim simulations determined the amount of water available for recirculation. Recharge used for Scenario 4 was identical to Scenario 3 and is shown on Figure 7-6. In Scenario 4, when Comal Springs was above 225 cfs, 10,000 AF/month was transported from a hypothetical wellfield in Medina County (near the unused permit well field) to the Lower Verde Type 2 recharge site. Unlike Scenario 3, the additional recharge (above 10,000 AF/month) was not pumped for use but instead was allowed to remain in the aquifer. In addition, the non-circulated water was not subject to recapture in subsequent stress periods. Figure 7-9 shows the total volume of enhanced pumping and pumping for recirculation for Scenario 4. When compared to the enhanced/recirculation pumping in Scenario 3 (Figure 7-7), the additional enhanced pumping associated with Scenario 3 is evident.

Enhanced pumping was calculated per stress period by using the recovery factors, described in Section 7.1.1 above, which are linked to the location where recharge was applied. If the baseline simulation showed Comal Springs was less than 40 cfs, no enhanced pumping occurred. Enhanced pumping was reactivated when springflow recovered, but stopped again when springflow exceeded 225 cfs. As in other scenarios, enhanced pumping was capped at 100,000 AF/month to prevent pumping cells from becoming dry in the model and to create a reasonable upper limit of water removed from the aquifer in a single month. When Comal Springs was over 225 cfs, 10,000 AF/month was added as recharge in

the next stress period (the next month). No additional enhanced pumping occurred when Comal Springs flow was above 225 cfs.

7.4.2. RESULTS OF SCENARIO 4

The yield of Scenario 4 recharge with enhanced pumping is shown as the annual yield and the yield as a percent of enhanced recharge on Tables 7-11 and 7-12, respectively. The total yield for each model section is shown on Figure 7-10.

Table 7-11: Yield of Scenario 4

Model Section	Portion of Enhanced Recharge Contributing to: (AFY)					
	Enhanced Pumping	Permit Pumping	Recirculation Pumping	Comal Springs	Other Springs	Remaining in Aquifer
1947-1973	99,153	11,619	17,015	11,340	18,915	34,767
1974-2000	84,361	40,461	66,119	76,909	92,607	41,619
2001-2027	90,717	28,790	19,697	23,520	32,863	41,330

Table 7-12: Yield of Scenario 4 as a Percent of Enhanced Recharge

Model Section	Portion of Enhanced Recharge Contributing to: (% of total recharge)					
	Enhanced Pumping	Permit Pumping	Recirculation Pumping	Comal Springs	Other Springs	Remaining in Aquifer
1947-1973	51%	6%	9%	6%	10%	18%
1974-2000	23%	11%	18%	21%	25%	11%
2001-2027	46%	15%	10%	12%	17%	21%

**Percentages for model sections 2 and 3 maybe higher than 100 percent of recharge due to the carryover of water remaining in storage from the previous model period.*

While Scenario 3 and 4 had the same recharge, Scenario 4 did not allow enhanced pumping above the 225 cfs springflow trigger as evidenced by the smaller amounts of enhanced pumping in Table 7-11. Scenario 4 averaged 99,000 AFY and 84,000 AFY of enhanced pumping in the first and second sections of the model, lower than the 117,000 AFY and 187,000 AFY associated with Scenario 3. Permit pumping in the aquifer was increased in Scenario 4 by approximately 12,000 AFY to 40,000 AFY above baseline. In Scenario 3, Permit pumping was increased 4,000 to 13,000 AFY compared to baseline.

The benefit from recirculation in this scenario is expressed primarily as an increase in Comal Springs flow as shown on Figure 7-10. Throughout Scenario 4, Comal Springs is above baseline 87 percent of the time. Due to the decrease in enhanced pumping, the simulated Comal Springs flow is higher in Scenario 4 than in Scenario 3 for approximately 88 percent of the time by an average of 25 cfs. The benefit to Comal Springs was seen

mainly in the second section of the model, when most of the recirculation occurred. The total benefit to Comal Springs from Scenario 4 was approximately 11,000 AFY and 77,000 AFY over baseline for the first and second parts of the model, respectively.

Scenario 4 provided additional benefits to springflow and Permit pumping but did not provide improved benefit over Scenario 3 for enhanced pumping or recirculation pumping, since both types of pumping were capped. The primary change between the two scenarios was the increase in springflow for Scenario 4 at the expense of decreased pumping.

7.5. SCENARIO 5

Scenario 5 was developed to isolate the benefit of the recirculation portion of Scenario 4. To do this, the Scenario 4 limitations to enhanced pumping had to be reproduced without the added recirculation from the wellfield. The pumping restrictions of Scenario 4 had not been used in the former scenarios.

7.5.1. DESCRIPTION

The base enhanced recharge from Scenario 1 was used as shown on Figure 7-1. As in Scenario 4, enhanced pumping occurs when Comal Springflow is between 40 cfs and 225 cfs. Enhanced pumping was calculated per stress period by using the recovery factors, described in Section 7.1.1 above, as linked to the site where recharge was applied.

No recirculation occurs in this scenario and no additional pumping occurs when Comal Springs flow is above 225 cfs. Like Scenario 4, recharge is applied when springflow was over 225 cfs; but unlike Scenario 4, recharge was not recovered and was not subject to recapture in subsequent stress periods.

7.5.2. RESULTS OF SCENARIO 5

The yield of Scenario 5 is shown both annually and as a percent of enhanced recharge on Tables 7-13 and 7-14, respectively. The total yield for each model section is shown on Figure 7-11.

Table 7-13. Annual Average Yield of Scenario 5

Model Section	Portion of Enhanced Recharge Contributing to: (AFY)					
	Enhanced Pumping	Permit Pumping	Recirculation Pumping	Comal Springs	Other Springs	Remaining in Aquifer
1947-1973	99,644	13,836	0	11,655	19,427	31,638
1974-2000	83,657	35,596	0	81,208	95,539	36,458
2001-2027	100,296	22,854	0	19,541	31,031	39,011

Table 7-14. Yield of Scenario 5 as a Percent of Enhanced Recharge

Model Section	Portion of Enhanced Recharge Contributing to: (% of total recharge)					
	Enhanced Pumping	Permit Pumping	Recirculation Pumping	Comal Springs	Other Springs	Remaining in Aquifer
1947-1973	57%	8%	0%	7%	11%	18%
1974-2000	28%	12%	0%	27%	32%	12%
2001-2027	57%	13%	0%	11%	18%	22%

*Percentages for model sections 2 and 3 maybe higher than 100 percent of recharge due to the carryover of water remaining in storage from the previous model period.

The enhanced pumping wells were able to capture about 99,000 AFY and about 84,000 AFY of enhanced recharge in the first and second half of the model, respectively. This about the same as Scenario 4, as the increased recharge from recirculation provided limited additional recharge for recovery. While the total enhanced pumping was the same as Scenario 4, the percent of recharge captured was higher by approximately 5 to 10 percent. Because recirculation only occurs during wet times when enhanced pumping did not occur, the additional recirculation recharge did not significantly add to the total enhanced pumping. The benefit to Permit pumping was mixed, an increase of 4,000 AFY for Scenario 5 (no recirculation) compared to Scenario 4 (with recirculation) for the dry first part of the model. However, Scenario 5 saw a reduction in benefits to Permit pumping during the wet second half of the model compared to Scenario 4, when most recirculation occurred.

As shown by the volumes and percentages in Tables 7-13 and 7-14, and by the graph on Figure 7-11, this scenario had similar benefits to Scenario 4 for Comal Springs. The total springflow increase was similar (compare Tables 7-11 and 7-13 for Comal Springs). Scenario 5 exhibited a slight overall increase in springflow by an average of about 0.3 cfs above Scenario 4. However in Scenario 4, Comal Springs was kept flowing for three additional months during the drought of record, but ceased flow for some portion of the drought of record in both scenarios.

Overall, the recirculation component of Scenario 4 shows some benefit when compared to Scenario 5, but the benefits are judged to be relatively small. Although water supply is not benefitted substantially, additional enhanced pumping could be increased in both of these scenarios. No attempt was made to recapture the recharge applied when Comal Springflow was over 225 cfs, and this extra amount could add considerably to the total volume of pumping. However, the increased pumping would have to be balanced against the compensating reductions to springflow and/or Permit pumping.

7.6. SCENARIO NO. 6

Since the enhanced recharge program selected for the scenario development included the ability to convey water from Lake Dunlap back to the recharge zone, the possibility of using this pipeline for diverting excess springflow was considered. As previously defined, excess springflow refers to the increase in flow at Comal Springs as a direct result of enhanced recharge. In previous scenarios a portion of this enhanced recharge was intercepted and recirculated before discharge at Comal Springs. For this scenario, the excess springflow is recirculated downstream from the springs.

7.6.1. DESCRIPTION

Scenario 6 was developed to evaluate the benefit of recirculating Comal Springs flow after discharge from the aquifer. The enhanced recharge program from Scenario 1 was used for recharge (Figure 7-1). As in Scenario 4, enhanced pumping occurs when Comal Springs flow is above 40 cfs but below 225 cfs. Enhanced pumping was calculated per stress period by using the recovery factors, described in Section 7.1.1 above, and linked to recharge applied at sites within the four geographic areas.

Like Scenarios 4 and 5, recharge applied when springflow was over 225 cfs was not pumped for use (enhanced pumping) and was not subject to recharge recapture in subsequent stress periods. In this Scenario, when springflow was above 40 cfs, excess springflow was recirculated to the Lower Verde Type 2 recharge site in the following month.

The volume of excess springflow that could be recirculated is dependent on the amount and timing of enhanced recharge and enhanced pumping. Enhanced pumping could produce significantly different amounts of springflow with different scenario-imposed triggers. Excess springflow with and without enhanced pumping is evaluated by the two graphs on Figure 7-12. As shown on the figure, excess springflow could reasonably be selected from a wide range of scenarios. Using the same recharge as Scenario 1, the top figure shows the annual volume of excess springflow with no enhanced pumping and the bottom figure shows the annual volume of excess springflow with maximum enhanced pumping (pumping for recovery above Comal springflow of 40 cfs, also including time periods over 225 cfs). The regime selected for Scenario 6 was the same as Scenario 5 and is

between these two end members. The amount of recirculation added to the enhanced recharge program for Scenario 6 is shown on Figure 7-13 and averages about 46,000 AFY.

While the model can tabulate the amount of excess springflow due to a given recharge scenario, estimating actual excess springflow would require a detailed hydrologic analysis. Maximizing the capture of excess springflow as a source for recharge may prove difficult on a real-time basis. Factors similar to the pumping recovery factors could be developed based on specified management criteria.

7.6.2. RESULTS OF SCENARIO 6

The yield of Scenario 6 recharge with enhanced pumping is shown as the annual yield and the yield as a percent of enhanced recharge on Tables 7-15 and 7-16, respectively. The total yield for each model section is shown on Figure 7-14.

Table 7-15: Yield of Scenario 6

Model Section	Portion of Enhanced Recharge Contributing to: (AFY)					
	Enhanced Pumping	Permit Pumping	Recirculation Pumping	Comal Springs	Other Springs	Remaining in Aquifer
1947-1973	107,499	12,395	0	15,287	20,377	36,336
1974-2000	98,673	38,446	0	103,432	117,578	51,979
2001-2027	114,087	9,865	0	32,655	46,463	50,243

Table 7-16: Scenario 6 as a Percent of Enhanced Recharge

Model Section	Portion of Enhanced Recharge Contributing to: (% of total recharge)					
	Enhanced Pumping	Permit Pumping	Recirculation Pumping	Comal Springs	Other Springs	Remaining in Aquifer
1947-1973	56%	6%	0%	8%	11%	19%
1974-2000	26%	10%	0%	28%	31%	14%
2001-2027	57%	5%	0%	16%	23%	25%

Percentages for model sections 2 and 3 maybe higher than 100 percent of recharge due to the carryover of water remaining in storage from the previous model period.

Scenario 6 can be compared with Scenario 4 (which examined wellfield recirculation) and Scenario 5 (which used the same enhanced recharge without recirculation) to quantify the benefits of excess springflow recirculation. For Scenario 6, the enhanced pumping recovered an average of 107,000 AFY and 99,000 AFY in the first and second half of the model, respectively. The most enhanced pumping occurred in the third section of the model, 114,000 AFY. This pumping was higher than Scenario 4 (about 8 to 26 percent) as

the increased recirculation resulted in additional recharge of the enhanced pumping to capture. However, Permit pumping in Scenario 6 decreased or remained the same when compared to Scenarios 4 and 5.

Scenario 6 exhibited overall increases over Scenario 5 in springflow, especially during wet periods by an average of about 18 cfs. Scenario 6 also maintained Comal Springs flow above the critical period triggers of 150 cfs and 225 cfs for an additional 51 months. It should be noted that in both scenarios Comal Springs ceased to flow for some portion of the drought of record. The Scenario 6 springflow is compared to baseline conditions on Figure 7-14.

Overall, the recirculation component of Scenario 6 does show benefits over Scenario 5. Water supply benefits (enhanced pumping and Permit pumping) were increased by 800 AFY to 18,000 AFY, for dry and wet model sections respectively. In addition, Comal Springflow was increased overall by 4,000 to 22,000 AFY, for dry and wet model sections respectively. Recirculation of excess springflow generally performed better during wet periods, since springflow was only recirculated when springflow was above 40 cfs. The third section of the model shows the increased benefit over the first section of the model, even though natural conditions were identical. The increase is due to the increase in recharge during the second section of the model that increased aquifer storage and provided carry-over benefits. This increase demonstrates the residual benefit of long term implementation of an R&R program.

7.7. SCENARIO NO. 7

Scenario 7 builds on the foundations of the previous scenarios and modifies the program to maximize enhanced pumping and protect Comal Springs during low flows. The enhanced recharge in this scenario examines a subset of the Type 2 R&R sites, unappropriated water from the Guadalupe River, excess springflow, and unused rights. The recharge for scenario 7 is shown on Figure 7-15. This scenario eliminates recharge sites that appear less cost effective and examines the transport of excess springflow and enhanced recharge to more effective recharge sites.

7.7.1. DESCRIPTION

The enhanced recharge program selected for the scenario development included only eastern and central Type 2 R&R sites (Lower Hondo, Lower Verde, San Geronimo, Cibolo, and Lower Blanco). Three western Type 2 R&R sites (Indian Creek, Lower Frio, and Lower Sabinal) were removed from the program due to the large cost of these structures and the limited available water. The scenario also included diverting unappropriated water from the Guadalupe River from the Comfort (combined with Medina Lake) and Lake Dunlap diversion points. Unused groundwater permits from the Uvalde and San Antonio pools were also used as source water for the Dry Frio and Seco Creek R&R sites, respectively.

Enhanced recharge from Lake Dunlap was combined with excess springflow and transported to either Lower Verde or Cibolo recharge sites, depending on Comal Springs flow. When Comal Springs flow was above 225 cfs, Dunlap unappropriated water and excess springflow was pumped to Lower Verde to increase the storage time in the aquifer and benefits to pumping. When Comal Spring flow was less than or equal to 225 cfs, Dunlap unappropriated water and excess springflow was pumped to the Cibolo recharge site to provide a rapid response at Comal and San Marcos springs.

As previously defined, excess springflow refers to the increase in flow at Comal Springs as a direct result of enhanced recharge. For this scenario, the excess springflow is recirculated downstream from the springs. An interim model simulation was used to develop the potential amount of excess springflow associated with the enhanced recharge regime. The volume of excess springflow was reduced during dry times to ensure at least 40 cfs of springflow remained. As with previous scenarios, the use of unappropriated water from Lake Dunlap, Comfort, and Medina Lake diversion sites was capped due to pipeline capacity. The pipeline from Dunlap to Cibolo and Lower Verde was capped at 40,000 AF/month, the pipeline from Comfort to Medina Lake as capped at 15,000 AF/month and the pipeline from Medina Lake to San Geronimo was capped at 30,000 AF/month.

Enhanced pumping occurred in the model when Comal Springs flow was above 40 cfs. Enhanced pumping was calculated per stress period using the recovery factors, described in Section 7.1.1 above, and linked to recharge applied at sites within the four geographic areas. Because water recharged at Lower Blanco (or the San Marcos FRS) has little to no residence time in the aquifer, this recharge was not attempted to be captured by enhanced pumping.

7.7.2. RESULTS OF SCENARIO 7

The yield of Scenario 7 is shown as by the annual yield and the yield as a percent of enhanced recharge on Tables 7-17 and 7-18, respectively. The total yield for each model section is shown on Figure 7-16.

Table 7-17: Yield of Scenario 7

Model Section	Portion of Enhanced Recharge Contributing to: (AFY)				
	Enhanced Pumping	Permit Pumping	Comal Springs	Other Springs	Remaining in Aquifer
1947-1973	125,799	1,983	9,085	74,281	22,076
1974-2000	244,414	-16,665	34,753	156,363	36,041
2001-2027	133,672	12,935	16,740	88,708	28,428

Table 7-18: Yield of Scenario 7 as a Percent of Enhanced Recharge

Model Section	Portion of Enhanced Recharge Contributing to: (% of total recharge)				
	Enhanced Pumping	Permit Pumping	Comal Springs	Other Springs	Remaining in Aquifer
1947-1973	54%	1%	4%	32%	9%
1974-2000	57%	-4%	8%	36%	8%
2001-2027	55%	5%	7%	36%	12%

Percentages for model sections 2 and 3 maybe higher than 100 percent of recharge due to the carryover of water remaining in storage from the previous model period.

Scenario 7 indicates an average of 168,000 AFY of enhanced pumping over the model period with no significant negative impact to the Permit pumping or Comal Springs. Pumping during the wetter model section from 1974-2000 exceeds 244,000 AFY over baseline pumping. Figure 7-17 shows the annual enhanced pumping over time. This scenario shows a greater volume of enhanced pumping and a less negative impact to the aquifer when compared to the previous scenarios. Enhanced pumping represents an average of 55 percent of all enhanced recharge, but the capture percent increases to 71 percent for recharge at sites other than Lower Blanco, where recharge was not attempted to be captured. The percent of recharge captured is greater in Scenario 7 than previous scenarios because of the increased enhanced recharge at Lower Verde and decreased enhanced recharge at Cibolo. This difference in aquifer storage is reflected in the capture factors described in Section 7.1.1 above, allowing greater capture of water recharged at Lower Verde than at the Cibolo site.

In addition to pumping, Scenario 7 increases flow at Comal Springs by approximately 20,000 AFY, an average increase of 28 cfs over baseline conditions. Springflow was occasionally lower than baseline levels, but these times were limited and lasted only a short period of time. While Comal Springs was simulated as dry for a portion of the model time period, the enhanced recharge reduced the period from 45 months to 25 months. The Scenario 7 springflow is compared to baseline conditions on Figure 7-16.

Overall, applying enhanced recharge from Dunlap and excess springflow to Lower Verde and Cibolo, as needed, allowed for greater enhanced pumping without significant impacts to springflow. Also, the western Type 2 R&R sites being removed from the scenario did not have a measureable impact on the results.

7.8. SCENARIO SUMMARY

The seven scenarios discussed above reflect a range of options for an R&R program. The enhanced recharge and yield for average and drought conditions are summarized on Table 7-19 for scenario comparisons.

Table 7-19: Comparison of R&R Scenarios

Table 7-19a: Yield of Scenarios (AFY)

Abbreviated Name for Model Simulation	Recharge and Yield Average Conditions (1947-2027)					Recharge and Yield Drought Conditions (1947-1956)				
	Total Recharge (AFY)	Enhanced Pumping (AFY)	Permit Pumping (AFY)	Comal Springs (AFY)	Remaining in Aquifer (AFY)	Drought Recharge (AFY)	Drought Enhanced Pumping (AFY)	Drought Permit Pumping (AFY)	Drought Comal Springs (AFY)	Drought Remaining in Aquifer (AFY)
Scenario 1a (Without Enhanced Pumping)	215,123	0	62,519	74,377	15,909	112,962	0	18,994	32,366	49,810
Scenario 1b (With Enhanced Pumping)	215,093	149,741	6,533	15,143	9,831	112,935	76,822	-3,447	-3,814	33,989
Scenario 2	215,119	87,354	37,525	39,711	8,655	112,962	5,692	15,595	30,731	49,480
Scenario 3	248,846	139,579	10,160	18,978	11,487	116,940	75,927	-3,744	-620	34,755
Scenario 4	248,734	90,296	26,628	36,802	13,777	116,942	72,934	-2,258	-2,231	35,003
Scenario 5	215,110	93,380	23,802	37,011	12,995	112,931	72,934	-1,891	-2,115	34,410
Scenario 6	252,549	105,451	19,989	49,842	16,373	117,930	76,366	-12,313	652	42,814
Scenario 7	302,373	167,448	-551	20,057	10,911	127,763	79,765	-4,015	-3,469	34,866

Table 7-19b: Cost of Scenarios (\$M and \$/AF)

Abbreviated Name for Model Simulation	Costs (millions of dollars)		Annual Cost (dollars per AF) Average Conditions				Annual Cost (dollars per AF) Drought Conditions			
	Total Cost* (\$M)	Annualized Cost (\$M)	Total Recharge (\$/AF)	Total Pumping (\$/AF)	Comal Springs (\$/AF)	Pumping + Comal (\$/AF)	Drought Recharge (\$/AF)	Drought Pumping (\$/AF)	Drought Comal Springs (\$/AF)	Drought Pumping + Comal (\$/AF)
Scenario 1a (Without Enhanced Pumping)	\$1,775.9	\$278.0	\$1,292	\$4,446	\$3,737	\$2,030	\$2,461	\$14,634	\$8,588	\$ 5,412
Scenario 1b (With Enhanced Pumping)	\$1,775.9	\$278.0	\$1,292	\$1,779	\$18,355	\$1,622	\$2,461	\$3,618	NA	\$ 3,618
Scenario 2	\$1,775.9	\$278.0	\$1,292	\$2,226	\$7,000	\$1,689	\$2,461	\$13,058	\$9,045	\$ 5,344
Scenario 3	\$2,020.3	\$330.4	\$1,328	\$2,206	\$17,407	\$1,958	\$2,825	\$4,351	NA	\$ 4,351
Scenario 4	\$2,020.3	\$330.4	\$1,328	\$2,825	\$8,977	\$2,149	\$2,825	\$4,529	NA	\$ 4,529
Scenario 5	\$1,775.9	\$278.0	\$1,292	\$2,372	\$7,510	\$1,803	\$2,461	\$3,811	NA	\$ 3,811
Scenario 6	\$4,054.0	\$541.5	\$2,144	\$4,317	\$10,865	\$3,089	\$4,592	\$7,091	\$831,038	\$ 7,031
Scenario 7	\$3,863.2	\$521.9	\$1,726	\$3,127	\$26,021	\$2,792	\$4,085	\$6,543	NA	\$ 6,543

*Capital plus Other Project Costs (Appendix C)

The yield is represented as increases to enhanced pumping, Permit pumping, Comal Springs flow, and aquifer storage. Benefits to other springs are not included. These yields represent the output from the modeling runs previously described and allow relative comparisons among scenarios.

Costs for each scenario were developed from the element costs provided in Appendix C. For each scenario, costs represent Type 2 R&R structures, pipelines, and wellfields. The cost of these elements could be reduced by reducing capacity and thus the volume of recharge or recirculation. Our approach was to first examine scenarios that were capable of capturing a reasonable maximum of the available water while providing operational flexibility. Costs for each scenario are discussed further in Section 7.9.

The relative effectiveness of each scenario can best be evaluated in view of specific R&R management objectives. There are a variety of objectives that could be prioritized, some of which are competing for the same water. For example, enhanced pumping captures recharge that otherwise would have increased flow at Comal Springs. Potential management objectives include:

- Maximize flow to Comal Springs (including maintaining flow during the drought of record)
- Maximize enhanced pumping to recover enhanced recharge without significant impacts to other pumping or springflow
- Minimize cost per acre foot of enhanced recharge
- Minimize cost per acre foot of benefit from recharge (springflow, pumping, or both)

Because this study focused on yield and not demand, EAA and stakeholders will need to define reasonable targets for enhanced pumping levels and minimum springflow levels. Without clear and specific project objectives, no one scenario can be identified as the most optimal. Optimized scenarios for some regional management objectives include:

Scenario 1 (without enhanced pumping) maximizes flow to Comal Springs (both volume and rate). Comal Springs is simulated as not flowing for a total of three months. This scenario shows the lowest cost per acre foot of yield to Comal Springs. However, the lack of enhanced pumping significantly reduces the benefit to water supply.

Scenario 1 (with enhanced pumping) minimizes the cost per acre foot for water supply benefits (enhanced pumping and Permit pumping). While enhanced pumping was increased by an average of 150,000 AFY, Permit pumping was increased by 6,500 AFY.

Scenario 2 also results in a continuous flow at Comal Springs and allows limited enhanced pumping when springflow is over 225 cfs. This scenario blends the objectives of maintaining springflow and enhancing pumping. Using a high springflow rate as an

enhanced pumping trigger prevents the water supply benefit during average or dry times, presumably when it is most needed.

Scenario 5, along with Scenario 1 (without enhanced pumping), minimizes the total cost per acre foot of recharge. In addition, the benefits to Permit pumping and Comal Springs are among the highest of all scenarios and the benefit of enhanced pumping is within the range of the other scenarios. While this scenario does not specifically optimize for water supply or Comal Springs, it shows increased benefit in all categories at a relatively low cost.

Scenario 7 is optimized for enhanced pumping. The average annual enhanced pumping is the highest among all scenarios at 167,000 AFY. The cost per acre foot of water supply benefit is significantly higher due to the extension of the recirculation pipeline from Lake Dunlap to the Lower Verde recharge site. The scenario does not produce significant negative impacts on springflow or Permit pumping, demonstrating the ability to increase pumping from the aquifer by more than 25 percent. While the cost per acre foot of recharge is relatively low, much of this recharge results in increased yield to San Marcos Springs from recharge at Lower Blanco.

Scenarios 3, 4, and 6, as designed for this analysis, were performed within the bounds of the other scenarios for the objectives listed above. These scenarios often provided specific benefits but at additional costs. These scenarios could potentially be altered to better optimize for selected criteria.

For these scenarios, the stated project goal of increasing water supply through enhanced pumping competes directly with the recirculation components. In other words, because most scenarios were optimized for enhanced pumping, less water was available for recirculation. As such, the recirculation elements may appear to yield fewer benefits than may actually occur. In addition, the recirculation elements of **Scenarios 3 and 4** were somewhat arbitrarily limited by a theoretical recirculation wellfield with the increased conveyance and pumping costs. For recirculation of excess springflow, **Scenarios 6 and 7** provided benefits but these were over-shadowed by the cost of the large-capacity pipeline from Lake Dunlap to Lower Verde recharge site.

7.9. FACILITIES COSTS

The annual costs for each scenario were derived from itemized estimates for each element, described further in Appendix C. The elements that were included in each scenario and their costs are shown on Table 7-20. Element costs are divided into three major categories, Type 2 R&R Structures and Pump-overs, Pipelines, and Wellfields (including conveyance to the recharge zone). Pipelines represented a large portion of the cost, ranging from 53 percent of the total in Scenarios 3 and 4 to 84 percent of the total in Scenario 7. While the large pipeline costs in Scenario 7 significantly increase the total cost, the pipeline allows operational flexibility in transporting most of the available water to where it is needed in the aquifer. In particular, the pipeline connecting the Lake Dunlap diversion site to the

Lower Verde recharge site allows more enhanced recharge to be recovered by pumping without negatively impacting Comal Springs. As previously discussed, elements could be down-sized in the future for potential cost savings, if warranted. However, this would directly impact the simulated benefits and scenarios would need to be analyzed.

Table 7-20. Annualized Cost for Scenarios (in millions of dollars)

Element	Scenario 1	Scenario 2	Scenario 3	Scenario 4	Scenario 5	Scenario 6	Scenario 7
Type 2 R&R Structures							
Indian Creek with Pump-over	\$21.6	\$21.6	\$21.6	\$21.6	\$21.6	\$21.6	
Lower Frio	\$5.4	\$5.4	\$5.4	\$5.4	\$5.4	\$5.4	
Lower Sabinal	\$1.6	\$1.6	\$1.6	\$1.6	\$1.6	\$1.6	
Lower Hondo	\$1.6	\$1.6	\$1.6	\$1.6	\$1.6	\$1.6	\$1.6
Lower Verde	\$1.7	\$1.7	\$1.7	\$1.7	\$1.7	\$1.7	\$1.7
San Geronimo	\$1.0	\$1.0	\$1.0	\$1.0	\$1.0	\$1.0	\$1.0
Cibolo	\$4.1	\$4.1	\$4.1	\$4.1	\$4.1	\$4.1	\$4.1
Lower Blanco with Pump-over							\$9.0
Pipelines							
Dunlap to Cibolo	\$102.7	\$102.7	\$102.7	\$102.7	\$102.7		
Dunlap to Lower Verde (via Cibolo)						\$366.3	\$366.3
Comfort/Medina to San Geronimo	\$63.1	\$63.1	\$63.1	\$63.1	\$63.1	\$63.1	\$63.1
Well fields							
Unused Rights - Uvalde	\$22.7	\$22.7	\$22.7	\$22.7	\$22.7	\$22.7	\$22.7
Unused Rights - Medina	\$52.4	\$52.4	\$52.4	\$52.4	\$52.4	\$52.4	\$52.4
Recirculation Well field (Medina)			\$52.4	\$52.4			
Total Annual Cost	\$277.9	\$277.9	\$330.3	\$330.3	\$277.9	\$541.5	\$521.9

7.10. DROUGHT YIELD

According to Regional Water Plan guidance, the TWDB recommends that water management strategies should consider the quantity and reliability of water available under drought-of-record conditions. Because the drought-of-record had been defined in previous evaluations as the combined effects from 1947 through 1956, the results of the seven scenarios during this time period were provided previously (Table 7-19). Based on guidance provided by EAA and San Antonio Water System (SAWS), the results of the scenarios for the one worst year of the drought (1956 conditions) are also presented.

These results are referred to in this report as “drought yield.” This drought yield is generally equivalent to the term “firm yield” applied to the evaluation of a surface water supply, as discussed in more detail below.

In TWDB guidelines for regional water plan development, a detailed discussion for the evaluation of firm yield from surface water supplies is provided (TWDB, March 2008). The term, *firm yield*, is not applied to groundwater supplies in the guidance document. Rather, TWDB guidance defined the amount of groundwater available from a water management as “the greatest annual amount of water available from an aquifer without violating the most restrictive physical and/or regulatory conditions limiting withdrawals under drought-of-record conditions.” (TDWB, March 2008).

None of the scenarios analyzed in this report were optimized for drought yield. All scenarios ceased enhanced pumping when Comal Springs were below 40 cfs to ensure regional protection of the springs. To increase drought yield, enhanced pumping could be increased, with the amount varying greatly with location and rates. As noted in previous analyses, the distribution of pumping in this aquifer is a major controlling factor as to whether springflow will be adversely impacted (LBG-Guyton, 2008).

For this analysis, drought yield is presented for two annual periods. One period reflects the actual model and management conditions for the year 1956, the worst year in the drought of record. The second period is labeled 2010 and represents the third section of the model where hydrologic conditions for the drought of record were repeated following a wetter period of the model. Note that the notation of 2010 simply indicates the 10th year of the model extension past 2000 and does not reflect actual predicted conditions for the year 2010. These two periods are shown on Tables 7-21a and 7-21b on the following page.

Table 7-21: Drought Yield

Table 7-21a: Drought Yield 1956

Abbreviated Name for Model Simulation	Drought Yield for 1956					Costs			
	Drought Recharge (AFY)	Enhanced Pumping (AFY)	Permit Pumping (AFY)	Comal Springs (AFY)	Remaining in Aquifer (AFY)	Annualized Capital Cost (dollars)	Drought Recharge (\$/AF)	Drought Pumping (\$/AF)	Comal Springs (\$/AF)
Scenario 1a (without Enhanced Pumping)	92,043	0	-33	25,375	47,390	\$277,958,375	\$3,020	NA	\$10,954
Scenario 1b (with Enhanced Pumping)	91,964	0	-36	10,095	65,344	\$277,958,375	\$3,022	NA	\$27,534
Scenario 2	92,043	0	-28	25,245	47,547	\$277,958,375	\$3,020	NA	\$11,011
Scenario 3	91,969	0	-53	12,684	64,720	\$330,353,181	\$3,592	NA	\$26,044
Scenario 4	91,984	0	-49	10,635	64,562	\$330,353,181	\$3,591	NA	\$31,064
Scenario 5	91,892	0	-27	10,277	64,984	\$277,958,375	\$3,025	NA	\$27,046
Scenario 6	93,505	0	-6,250	13,766	67,800	\$541,514,867	\$5,791	NA	\$39,337
Scenario 7	92,517	0	-28	10,751	64,160	\$521,914,583	\$5,641	NA	\$48,546

Table 7-21b: Drought Yield 2010*

Abbreviated Name for Model Simulation	Drought Yield for 2010*					Costs			
	Drought Recharge (AFY)	Enhanced Pumping (AFY)	Permit Pumping (AFY)	Comal Springs (AFY)	Remaining in Aquifer (AFY)	Annualized Capital Cost (dollars)	Drought Recharge (\$/AF)	Drought Pumping (\$/AF)	Comal Springs (\$/AF)
Scenario 1a (Without Enhanced Pumping)	92,003	0	23,843	37,751	13,550	\$277,958,375	\$3,021	\$11,658	\$7,363
Scenario 1b (with Enhanced Pumping)	91,930	68,038	-80	-1,084	12,199	\$277,958,375	\$3,024	\$4,090	NA
Scenario 2	92,010	0	11,998	36,520	26,782	\$277,958,375	\$3,021	\$23,166	\$7,611
Scenario 3	91,967	68,038	-70	-173	10,706	\$330,353,181	\$3,592	\$4,860	NA
Scenario 4	91,979	58,139	2,616	4,744	11,438	\$330,353,181	\$3,592	\$5,437	\$69,633
Scenario 5	91,949	68,038	-74	203	10,057	\$277,958,375	\$3,023	\$4,090	\$1,368,378
Scenario 6	100,320	77,495	-3,424	12,889	-3,556	\$541,514,867	\$5,398	\$7,311	\$42,014
Scenario 7	96,599	73,401	-2,940	546	9,676	\$521,914,583	\$5,403	\$7,407	\$955,904

* Results from extension of model to repeat hydrologic conditions of 1956. Analysis does not predict actual conditions for the year 2010.

NA - not applicable - no benefits.

As shown on the preceding tables, recharge for the drought year is around 90,000 AFY for both 1956 and 2010 and reflects the amount of unused groundwater pumping rights being conveyed to the recharge zone. For 1956 (Table 7-21a), there is no yield for pumping due to the criteria set for the scenarios. For all scenarios, enhanced pumping was suspended when Comal Springs was below 40 cfs; Comal Springs flow was below 15 cfs for the entire year. Permit pumping shows very small amounts of negative pumping as tabulated in the model and reflects only minor changes to the baseline scenario. Increases to Comal Springs range from 10,095 AFY to 25,375 AFY. Most of the water recharged remains in storage in the aquifer. Costs on an AF basis are very high for all components. Since the scenarios did not allow enhanced pumping, there is no benefit to water supply during this one year.

On Table 7-21b, the results are presented from the third section of the model that repeats drought-of-record hydrologic conditions in 2010. However, because these conditions follow the wetter years of the second model section, benefits to water supply occur for most scenarios because Comal Springs is above 40 cfs for three months of the year (allowing Enhanced pumping to occur). However, costs are very high due to the inclusion of most of the regional surface water diversion components.

7.11. OPTIMIZING CONSIDERATIONS

If enhanced pumping is not needed over certain quantities or during very wet times, the amount of water available for recirculation could increase significantly. Moving this water west to the recharge zone could have more potential long-term benefit to aquifer levels and springflow than analyzed in this study. If specific objectives for enhanced pumping and minimum springflow could be developed, additional analyses could better quantify the amount of excess springflow available for recharge.

Projects have been optimized for yield with an attempt to capture a reasonable maximum amount of available water. However, the maximum amount of flood flows available at most R&R sites seemed unreasonably high for complete capture and conveyance. For pipelines, it was assumed that 660 cfs (40,000 AF/month) was a reasonable upper limit for the volumes of water available. Additional analysis of decreasing pipeline sizes could result in more optimized costs.

The western Type 2 R&R recharge sites appear less economical due to the low availability of unappropriated water. As such, sites from Indian Creek through Lower Sabinal were dropped from Scenario 7 with little observed impact. These sites would likely be economical if marketable water could be obtained.

The Lower Verde recharge site seems favorable for aquifer response, infiltration rates, and available capacity in the Type 2 recharge structure. As such, this site was targeted for recirculation water. If recirculation does not occur here, the Medina wellfield component for unused rights could be updated to target this site rather than the Seco Creek site. This should improve the economics of the wellfield due to a shorter pipeline.

Previous R&R investigations considered a regional pipeline that connected all Type 2 recharge sites. While such a pipeline would provide maximum operational flexibility, it was judged cost prohibitive and not included in scenario development. Preliminary costs for the 175-mile alignment developed by NRS Engineering indicated the following:

- Total Capital Cost: \$ 3,690,900,000
- Total Other Project Cost: \$ 1,885,000,000
- Total Annual Cost: \$ 670,700,000

Since these costs are approximately twice the cost of a pipeline from Lake Dunlap to the Lower Verde recharge site, the pipeline was shortened for costing and analysis purposes. In addition, the pipeline from Lake Dunlap to the Lower Verde recharge site represents a significant portion of an R&R program cost. Additional optimization of pipeline capacity should be considered to decrease costs.

As previously discussed, the scenarios provided herein are not optimized for “drought yield” or “sustained pumping yield,” as defined in the 2006 Regional Water Plan (SCTRWPG, 2006). Such scenarios could be developed but would vary significantly depending on the location of the pumping.

8. CONCLUSIONS AND RECOMMENDATIONS

8.1. CONCLUSIONS

Based on the analyses provided in this report, the following conclusions can be made.

- An R&R program can be developed that increases water supply while maintaining minimum required springflow.
- Considerations for optimizing the program should be based on specific management objectives developed by EAA and stakeholders such as when and under what conditions additional water supply is needed and what minimum flows are required for Comal Springs and during what time period.
- Using the water balance output from the model, benefits from enhanced recharge can be assessed for five main categories: enhanced pumping (for recharge recovery), Permit pumping (due to lessening of CPM stages), Comal Springs, springflow at other springs, and aquifer storage (water remaining in aquifer).
- Baseline conditions developed for this study indicate that the aquifer is in critical period stages for most of the model time period. For the San Antonio Pool, critical period stages occur 65 percent of the time. Springflow at Comal Springs is significantly lower than the historical record and ceases to flow for 25 months during the drought of record (1947-1956).
- The EAA model, as modified, simulates newly-adopted CPM rules and pumping cap, and provides a valuable tool for evaluating R&R scenarios.

RECHARGE LOCATIONS AND YIELD

- Enhanced recharge produces immediate benefits to Permit pumping. Benefits are less pronounced for average or wet conditions, but occur anytime the pools are in critical periods.
- Modeling indicates that increases to Permit pumping occur before increases to spring flow.
- Enhanced recharge benefits springs other than Comal Springs, primarily during average and wet conditions.
- Enhanced recharge at the central recharge sites provides more combined benefits to Permit pumping and Comal Springs flow than recharge at the eastern or western sites.
- The eastern and western recharge sites provide increased discharge to springs other than Comal Springs (specifically San Marcos and Leona springs).
- Groundwater modeling confirms the relationship between aquifer retention time and recharge location, i.e., eastern recharge sites are most effective for springflow maintenance and western recharge sites are most effective for long-term storage.

- Modeling indicates that at least 117,000 AFY of enhanced recharge during dry conditions is needed for maintaining Comal Springs flow at 40 cfs at the San Geronimo R&R site; more than twice that amount is needed for maintaining springflow at 150 cfs. Much more water is needed if recharge occurs west of the San Geronimo recharge site. Under average conditions, only about 25,000 AFY is needed at the San Geronimo site to maintain Comal Springs at 150 cfs.
- The Lower Blanco recharge site is ineffective for increasing water supply or maintaining springflow at Comal Springs. Recharge here contributes mainly to San Marcos Springs. However, significant quantities of water appear available for recharge and the costs for a Type 2 structure appear reasonable. Over time, continued enhanced recharge is expected to provide some benefits to Comal Springs.

SOURCE WATER

- Surface water modeling indicates unappropriated water is available at each of the potential R&R sites analyzed for this study. Two diversion sites on the Guadalupe River, Canyon Lake and Lake Dunlap, contain the largest amounts of unappropriated water on an average annual basis. In general, much more water is available at the eastern diversion/recharge sites.
- Surface water modeling with the Nueces WAM indicates significantly less unappropriated surface water available for recharge than previous studies mainly because storage rights in the Choke Canyon Reservoir/Lake Corpus Christi are being fully honored in the WAM. Past studies have assumed that impacts on Corpus Christi water supply and estuarine inflows would be mitigated with alternative water sources and/or financially.
- Marketable water has been estimated at the diversion sites. Only small amounts of marketable water appear to exist at the Cibolo, San Geronimo, and Lower Verde recharge sites. Significant amounts of marketable water may exist at the Lower Sabinal, Lower Frio, and Indian Creek recharge sites. However, the availability of such water is uncertain and R&R scenarios did not include these totals.
- Unused Edwards Aquifer withdrawal permits represent a potentially large amount of water for recharge. Even after reductions are made to estimate the amount of base permit that could not be leased for off-site pumping, average unused permits from both pools appear to be available. For the Uvalde Pool, an average amount of about 51,215 AFY may be available. For the San Antonio Pool, an average amount of about 97,630 AFY is estimated. Recent information on long-term leases indicates that annual payments for leased water are made whether the water is needed or not. This indicates that water may be available in wet periods for recirculation. Modeling indicates advantages for pumping the water to certain recharge sites for long-term storage.

- The Guadalupe River diversion point at Lake Dunlap was considered optimal over the diversion points at Canyon or Comal River because Dunlap provided more unappropriated water and greater flexibility to capture excess springflow.
- Enhanced recharge produces increases in springflow that could be captured downstream and recirculated back to the aquifer as a potential source of long-term recharge. The amount of excess springflow is related to the amount of enhanced pumping that is conducted for recharge recovery. There may be regulatory uncertainty as to the availability of this water, but analyses were conducted as required by the Scope of Services for this project (Appendix A).
- Recirculation could also occur with a recirculation wellfield that could return unneeded water from Recharge Recovery permits back to the recharge zone. Wellfields were sized for capturing available unused Edwards Aquifer permits and would need to contain a larger capacity if also used for recirculation.

R&R COMPONENTS

- A Type 1 structure on Seco Creek (or other centrally-located recharge site) would need a large capacity (100,000 AF or greater) to provide more significant advantages than a direct infiltration structure. The analysis conducted for this study did not indicate sufficient benefits to justify the inclusion of a Type 1 structure. If determined to be beneficial for future management objectives, other Type 1 structures for the central R&R sites should be re-assessed (Lower Verde to Lower Frio).
- It was judged cost prohibitive to size pipelines to capture the maximum available water due the infrequent occurrence and very large quantity. In addition, modeling indicates that the highest peak flows are not as beneficial over time since they occur at a time when water levels are already relatively high. Nonetheless, this study provides costs that optimize capture of a reasonable maximum quantity that optimizes yield rather than costs. Additional pipeline and reservoir sizing were beyond the scope of this project.

SCENARIO DEVELOPMENT

- Recovery factors, such as those developed for this study, can be used for implementation of ARSR rules for capture of enhanced recharge through enhanced pumping.
- Recovery factors generally allow for capture of a larger portion of enhanced recharge from western and central R&R sites.
- Much of the recharge water occurs during wet times and may be held longer in aquifer storage with recharge at the western sites.
- Most of the source water is available at eastern locations during wet conditions.

- Pipeline costs, mainly those needed for Guadalupe diversions, account for more than 50 percent of R&R scenario costs. Pipeline capacities may require additional optimization steps to reduce costs and meet management objectives.
- Without more specific objectives for an R&R program, no one scenario stands out as the most optimal. Several scenarios meet individual potential objectives. The optimal program would combine components of scenarios to meet specific objectives.
- Yields as presented in this study are long-term averages; short-term results may be more or less favorable than presented.
- Yields are indicative of regional benefits and may not be representative of local conditions.
- R&R programs may be further optimized for local projects and short-term results based on specified objectives.

8.2. RECOMMENDATIONS AND LIMITATIONS

This study evaluates regional R&R strategies with a revised groundwater model, current baseline conditions for CPM rules and pumping, and updates source water quantities and costs. The analyses were guided by the scope of work, providing a framework analysis for a variety of R&R components. The study does not evaluate all possible combinations of strategies at a sufficient level to recommend appropriate project phasing.

This study did not include a review or analysis of local water demand in the region, and scenarios do not attempt to provide water at a specific time or place to benefit a particular user. Scenarios are regionally-focused to analyze the benefits from the largest amount of enhanced recharge that could be reasonably available. Further, costs were based on facilities that provided the most operational flexibility. Optimizing considerations for cost and local objectives should be considered.

The study relies on previous estimates for reservoir capacities and percolation rates and does not provide additional analyses regarding recharge site limitations. Additional site-specific studies will be required to determine the optimal amount of enhanced recharge that could be captured, given the revised amounts of source water. Marketable water would provide benefits to a recharge program, especially for the western recharge sites. However, because of the uncertainty of leasing/purchasing such rights, scenarios did not include this additional potential source of enhanced recharge.

The WAM and EAA groundwater models used in this study represent the most current and technically-defensible tools with which to analyze R&R scenarios, but both contain limitations. For example, the monthly time step of the WAM ignores daily variations in source water that could be difficult to capture for enhanced recharge.

The groundwater model appears to provide an excellent tool for planning and analyzing aquifer management strategies, especially with respect to benefits relative to baseline conditions. However, its limitations should be considered, especially since it is less well-calibrated in the recharge zone where most of the initial impacts from enhanced recharge occur. Aquifer and springflow response may be quicker or more delayed than predicted by the model. In addition, small-scale pilot studies will not likely be sufficient to calibrate the response in real time. As such, it seems prudent to initiate aquifer management strategies based on specific objectives and reasonable and conservative assumptions. Over time, aquifer management can be re-assessed and adjusted to ensure a sustainable supply for all aquifer beneficial uses.

9. REFERENCES

- Edwards Aquifer Authority (EAA), Edwards Aquifer Authority Rules, July 22, 2008.
- Edwards Aquifer Authority (EAA), Edwards Aquifer Authority Hydrologic Data Report for 2006, July 2007.
- Edwards Aquifer Authority (EAA), Edwards Aquifer Authority Rules, February 14, 2006.
- Edwards Aquifer Authority (EAA), Edwards Aquifer Bibliography through 1997, prepared in cooperation with the U.S. Geological Survey, June 1998.
- Edwards Underground Water District (EUWD), Aquifer Management Plan for the Edwards-Balcones Fault Zone Aquifer, December 11, 1992.
- Green, R.T., Bertetti, F. P., Franklin, N.M., Morris, A.P., Ferrill, D.A., and Klar, R.V., Evaluation of the Edwards Aquifer in Kinney and Uvalde Counties, Texas, Geosciences and Engineering Division, Southwest Research Institute, San Antonio, TX and Raba-Kistner Consultants, Inc., San Antonio, TX, prepared for Edwards Aquifer Authority, June 19, 2006.
- Harbaugh, A.W., Banta, E.R., Hill, M.C., and McDonald, M.G., MODFLOW-2000, The U.S. Geological Survey Modular Ground-Water Model – User Guide to Modularization Concepts and the Ground-Water Flow Process, Open-File Report 00-92, 2000.
- HDR Engineering, Inc. (HDR), unpublished data files for monthly recharge amounts at Type 2 sites for SCTRWPG 2001 and 2006, provided by S. Vaughn, August 1, 2008.
- HDR Engineering, Inc. (HDR), Paul Price Associates, Inc., LBG-Guyton Associates, and Fugro-McClelland (SW), Inc., Trans-Texas Water Program, West Central Study Area, Phase II, Edwards Aquifer Recharge Analysis, March 1998.
- HDR Engineering, Inc. (HDR), Paul Price Associates, Inc., LBG-Guyton Associates, and H.B. Zachry Company, Trans-Texas Water Program, West Central Study Area, Phase I Interim Report, Draft Volume 4, prepared for San Antonio River Authority, San Antonio Water System, Edwards Underground Water District, Guadalupe-Blanco River Authority, Lower Colorado River Authority, Bexar Metropolitan Water District, Nueces River Authority, and Texas Water Development Board, December 1995.
- HDR Engineering, Inc. (HDR), Freese & Nichols, Fugro-McClelland, LBG-Guyton Associates, Paul Price Associates, and International Aerial Mapping, Edwards Aquifer Recharge Enhancement Project Phase IVA, Nueces River Basin, prepared for Edwards Underground Water District, June 1994.
- HDR Engineering, Inc. (HDR), HDR Engineering, Inc. (HDR), Paul Price Associates, Inc., LBG-Guyton Associates, and Espey-Huston & Associates, Inc., Trans-Texas Water Program, West

Central Study Area, Phase I Interim Report, Volumes 1 and 2, prepared for San Antonio River Authority, San Antonio Water System, Edwards Underground Water District, Guadalupe-Blanco River Authority, Lower Colorado River Authority, Bexar Metropolitan Water District, Nueces River Authority, and Texas Water Development Board, May 1994.

HDR Engineering, Inc. (HDR) and Espey, Huston & Associates, Guadalupe – San Antonio River Basin Recharge Enhancement Study, Volume II – Technical Report, prepared for Edwards Underground Water District, September 1993.

HDR Engineering, Inc. (HDR) and Paul Price Associates, Nueces River Basin Regional Water Supply Planning Study, Phase III – Recharge Enhancement, Final Report, prepared for Nueces River Authority, Edwards Underground Water District, City of Corpus Christi, South Texas Water Authority, Texas Water Development Board, November 1991.

HydroGeoLogic, Inc, User’s Manual for the Groundwater Management Package for MODFLOW-2000, prepared for Edwards Aquifer Authority, December 2005.

HydroGeoLogic, Inc., Reference Manual for the Groundwater Management Package for MODFLOW, prepared for Edwards Aquifer Authority, November 2004.

LBG-Guyton Associates, Simulated Impacts Associated with the Cibolo Creek Transfers Using MODFLOW-NR and Senate Bill 3 Assumptions, prepared for the Edwards Aquifer Authority, May 5, 2008.

LBG-Guyton, Aqua Terra Consultants, in association with Espey Consultants, Inc., Bradford Wilcox, Ph.D., and GlynData, HSPF Recharge Models for the San Antonio Segment of the Balcones Fault Zone, Edwards Aquifer, prepared for Edwards Aquifer Authority, January 2005.

Lindgren, R.J., Dutton, A. R., Hovorka, S.D., Worthington, S.R.H., and Painter, Scott, Conceptualization and Simulation of the Edwards Aquifer, San Antonio Region, Texas, U.S. Geological Survey Scientific Investigations Report 2004-5277, 2004.

South Central Texas Regional Water Planning Group (SCTRWPG), 2006 Regional Water Plan, Volume II – Technical Evaluations of Water Management Strategies, with administration by San Antonio River Authority, with technical assistance by HDR Engineering, Margaret Dalthorp, January 2006.

South Central Texas Regional Water Planning Group (SCTRWPG), Regional Water Plan, Volume I – Executive Summary and Regional Water Plan, Volume II – Technical Evaluations of Alternative Regional Water Plans, Volume III – Technical Evaluations of Water Supply Options, with administration by San Antonio River Authority, with technical assistance by: HDR Engineering, Moorhouse Associates, Inc., Open Forum, in association with: Paul Price Associates, Inc., LBG-Guyton Associates, R.J. Brandes Company, The Wellspec Company, January 2001.

Texas Department of Water Resources (TDWR), Ground-Water Resources and Model Applications for the Edwards (Balcones Fault Zone) Aquifer in the San Antonio Region, Report 239, October 1979.

Texas State Legislature, Amendments to Senate Bill (S.B.) 3, Article 12, Edwards Aquifer Authority, June 16, 2007.

Texas State Legislature, Senate Bill (S.B.) 1477, Chapter 626, Edwards Aquifer Authority Act (including amendments through June 16, 2007), May 30, 1993.

Texas Water Development Board (TWDB), General Guidelines for Regional Water Plan Development (2007 – 2012), Division of Regional Water and Flood Planning and Natural Resource Information Systems, March 28, 2008.

Texas Water Development Board (TWDB), Guidelines for Regional Water Planning Data Deliverables (2007 – 2012), Division of Regional Water and Flood Planning and Natural Resource Information Systems, February 25, 2008.

Todd Engineers, Analysis of Recharge and Recirculation, Edwards Aquifer, Phase 1, September 2004.

Todd Engineers, Analysis of Recharge and Recirculation, Edwards Aquifer, Phase 2, May 2005.

U.S. Fish & Wildlife Service (USFWS), San Marcos and Comal Springs and Associated Aquatic Ecosystems (Revised) Recovery Plan, prepared by the San Marcos/Comal Recovery Team and USFWS, February 14, 1996.

Vaugh, Sam, HDR Engineering, personal communication, July 17, 2008.

10. DEFINITION OF TERMS

The technical evaluations in this report are complex and require consistent use of certain terms for effective communication. We have attempted to avoid the use of technical jargon; nonetheless, the use of specifically-defined key terms was helpful in explaining concepts and analyses in this report. This glossary provides definitions and short explanations of key terms used in this report for the purposes of communicating our analyses more effectively. It builds on terms defined by EAA and other in previous analyses, but includes new terms defined specifically for this report (e.g., enhanced pumping).

Baseline Recharge: The amount of natural recharge to the Edwards Aquifer applied to the baseline scenario absent R&R strategies. This recharge, including location, quantity, and timing from 1946 through 2000, is taken from the calibrated MODFLOW computer model developed by the U.S. Geological Survey (USGS) for EAA (referred to herein as the EAA model) and applied in this report.

Baseline Pumping: The amount of pumping allowed by Edwards Aquifer withdrawal permits currently capped at 572,000 AFY and subjected to the CPM rules recently amended by S.B. 3, as simulated in the Baseline Scenario from 1947 through 2000.

Baseline Scenario: Baseline conditions used in this report that reflect changes to the total permitted amount of pumping and newly-adopted CPM rules. The baseline scenario reflects current conditions (including permitted withdrawals) without R&R management strategies and provides a yardstick against which R&R scenarios can be measured.

Benefit (or Yield): The amount of water above baseline provided by an R&R component or R&R scenario to springflow, pumping, or aquifer storage.

Critical Period Management (CPM) Rules: EAA rules defining critical period stages, triggers, and associated requirements for withdrawal reductions. These CPM rules have been revised by recently adopted amendments to the EAA Act in Senate Bill No. 3, Article 12 (S.B. 3) (Texas State Legislature, 2007). These amendments raised the cap on annual withdrawal permits from 400,000 AFY to 572,000 AFY by eliminating previously-designated Junior and Senior withdrawal rights.

Drought Yield: The annual amount of water available from a management strategy during the worst year of the drought of record (1956 conditions).

EAA Model: The MODFLOW groundwater flow model developed by USGS and others for EAA (Lindgren, et al., 2004).

Enhanced Pumping: The amount of additional pumping *above baseline pumping* that could be achieved under certain conditions to recover all or a portion of enhanced recharge for direct use. Enhanced pumping was controlled by an evaluation of recovery factors

developed at each recharge location for this report. Recovery factors were based on analyses of the retention time of enhanced recharge in the aquifer for various recharge amounts at various locations. The amount of enhanced pumping was further controlled by certain criteria developed for each scenario. Enhanced pumping simulates what an applicant might recover under an EAA Recharge Recovery Permit.

Enhanced Recharge: The recharge resulting from R&R strategies that is above the amount of recharge that would have occurred naturally at any given location, defined as baseline recharge. Enhanced recharge in this report typically occurs at previously-defined Type 2 (recharge zone) structures.

Excess Springflow: The increase in flow at Comal Springs, *above baseline*, as a direct result of enhanced recharge.

Firm Yield: The volume of water available for water supply from the aquifer during the drought of record.

Marketable Water: The portion of the appropriated (or permitted) surface water at a particular location on a stream that has not been used historically and is not anticipated to be needed and used for some period of time in the future, i.e., several years. This is calculated using the WAM (water availability model).

Permit Pumping: Edwards Aquifer withdrawal permits currently capped at 572,000 AFY.

R&R Component: A separate and distinct R&R strategy involving a specified location for enhanced recharge, a specified source of recharge water, and specific elements necessary to move the water to the recharge zone.

R&R Element: A term designated in the costing analysis in Appendix C that refers to one item requiring a separate cost estimate. Example elements include a pipeline, a wellfield, or a recharge structure. A component is composed of one or more elements.

R&R Scenario: A combination of components that represents a potential regional R&R strategy.

Recharge Recovery Permit: Such a permit allows the holder to pump the amount of enhanced recharge water less any losses to springflow or other aquifer discharge. Further, the permit provides that pumping to recover recharge is not subject to withdrawal reductions of CPM rules. The increase in pumping cannot unreasonably negatively affect other permittees including those holding regular withdrawal permits. In addition, required minimum springflows cannot be adversely impacted beyond conditions that would have occurred if the recharge/recovery project did not exist. Aquifer Recharge and Storage Rules (ARSR) permits can be acquired to increase water withdrawn from the aquifer for beneficial use or to maintain/increase springflow of Comal or San Marcos springs.

Recirculation: Returning all or a portion of enhanced recharge back to the recharge zone for storage. This would likely occur when a Recharge Recovery Permit holder recovers all or a portion of enhanced recharge that is not needed at that time for direct use.

Recovery Factors: The portion of enhanced recharge that could be recovered by wells over time for a specific recharge location.

Retention Time: The amount of time that enhanced recharge remains in the aquifer before being discharged at wells or springs.

Source Water: Water potentially available for recharge enhancement. Sources evaluated in this analysis include:

- Surface water: unappropriated or marketable streamflow
- Groundwater: unused groundwater permits
- Recirculated surface water: springflow in excess of baseline that is a direct result of enhanced recharge
- Recirculated groundwater: water recovered under a Recharge Recovery Permit that is conveyed back to the recharge zone rather than used directly for water supply

Type 1 and Type 2 Recharge Structures: Type 1 recharge structures are located upstream of the recharge zone and hold streamflow behind an engineered dam for timed releases to the recharge zone. Type 2 structures are located on the recharge zone and hold streamflow to allow for direct infiltration into the aquifer.

Unappropriated Water: Surface water at designated stream locations that is not appropriated and available for permitting. This is calculated using the TCEQ WAM (water availability models).

Unused Groundwater Permits: Unused Edwards Aquifer withdrawal permits available for use as enhanced recharge. The amounts used in the analysis were based on unused rights tabulated from 1999 through 2006 by county and permit type as provided by EAA. Average unused amounts were corrected for some portion of the base irrigation permits that require that the water be withdrawn from the land where the permit originates.

Water Availability Model (WAM): Water Availability Models developed and used by the Texas Commission of Environmental Quality (TCEQ). For this analysis, the WAM was modified to be consistent with the baseline scenario (using groundwater model-simulated springflow as an input) and used to estimate available quantities of water for potential diversion and use for R&R purposes. Estimates for both unappropriated and marketable water were developed on certain drainages as defined in the Scope of Services.

Yield (or Benefit): The amount of water above baseline provided by an R&R component or R&R scenario to springflow, pumping, or aquifer storage.

FIGURES

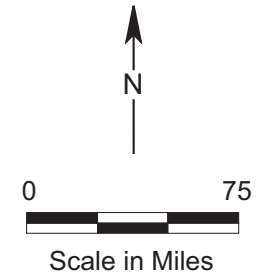

LEGEND

- Recharge Site
- ▲ Spring
- Monitoring Well
- - - County Line
- Stream/River

October 2008
 TODD ENGINEERS
 Alameda, California

Figure 1-1
 Study Area With
 R&R Recharge Sites

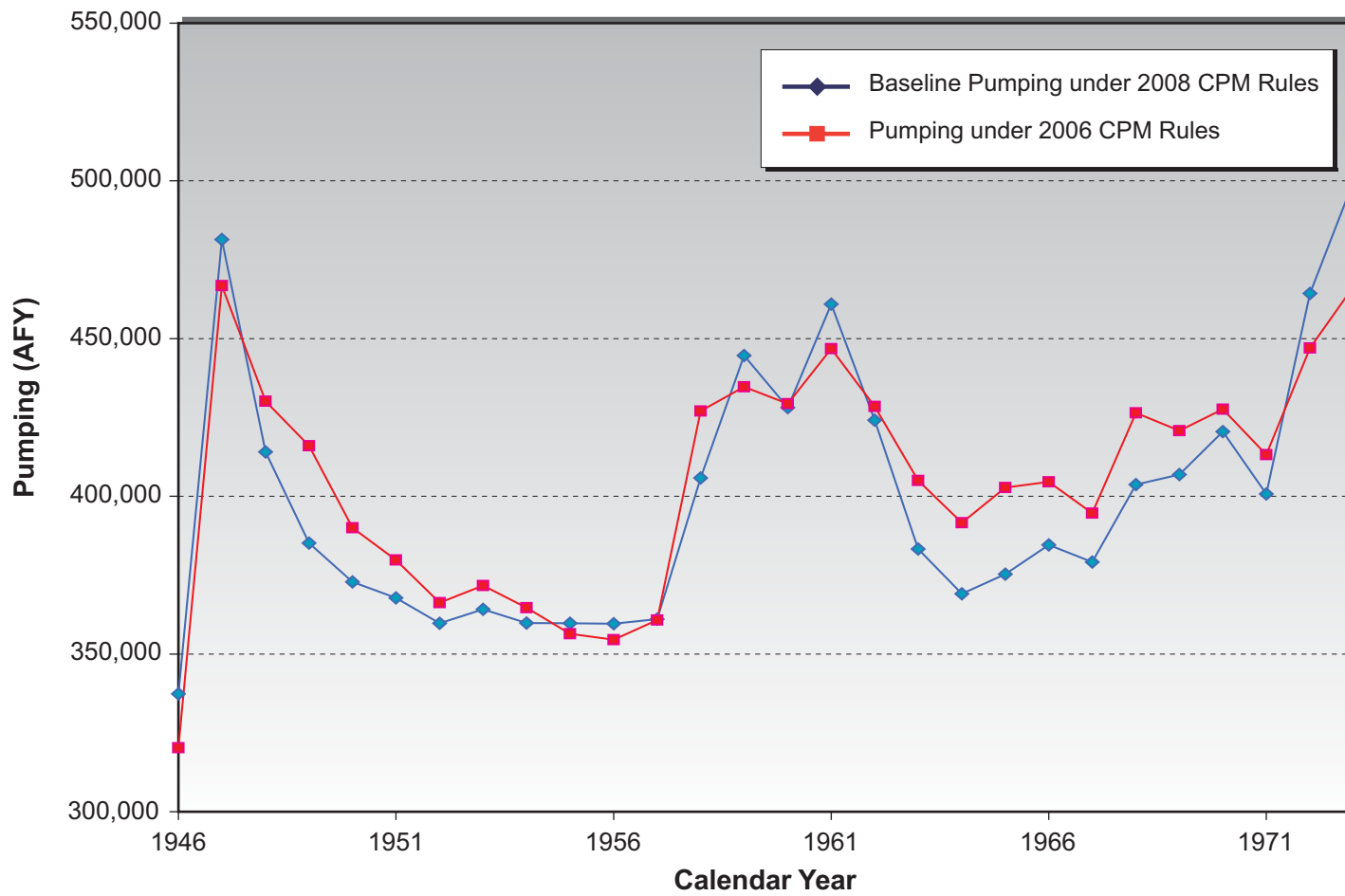

December 2008	Figure 3-1 Pumping Totals under CPM Rules
TODD ENGINEERS Alameda, California	

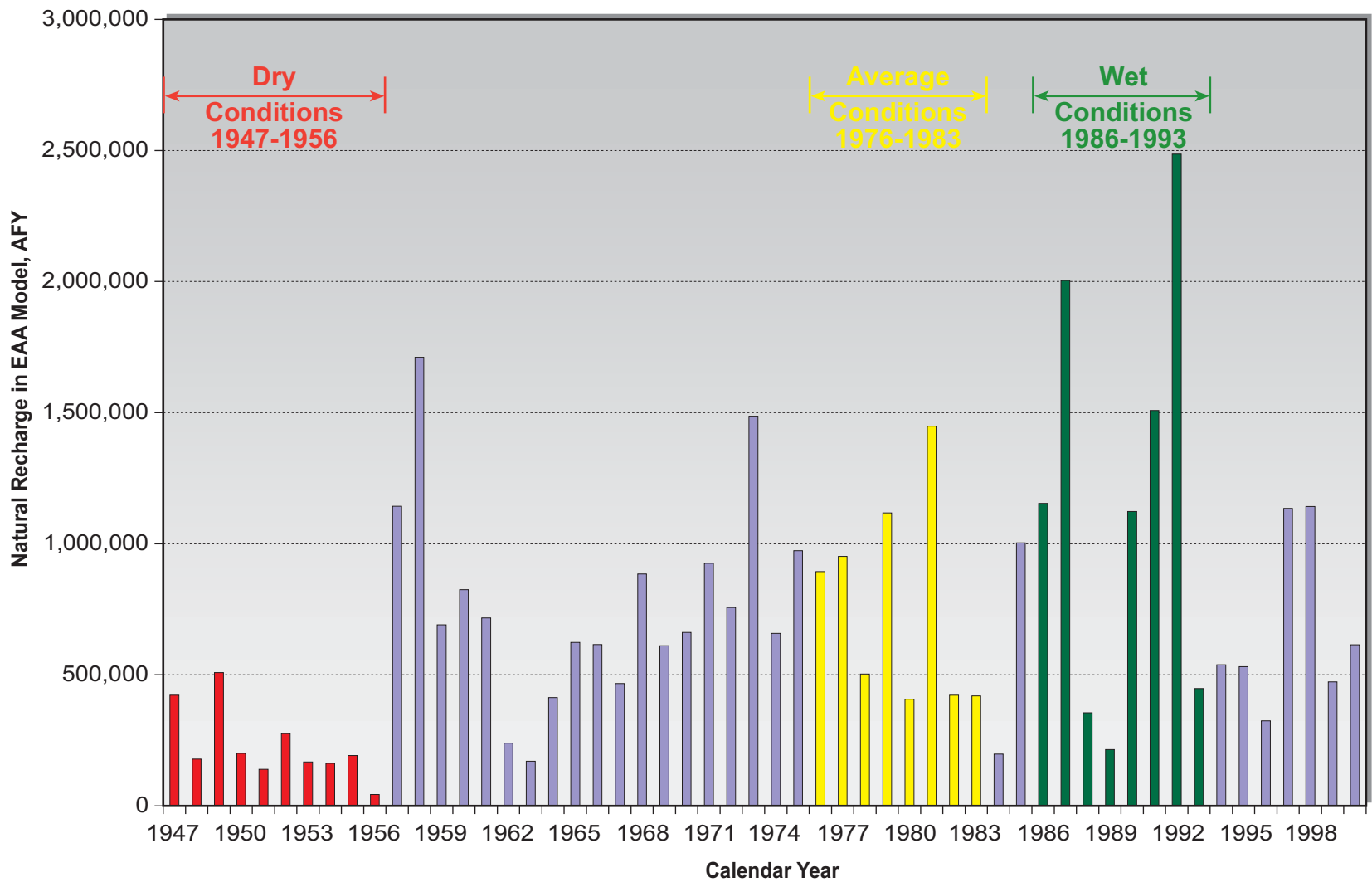

October 2008	Figure 3-2 Representative Hydrologic Cycles
TODD ENGINEERS Alameda, California	

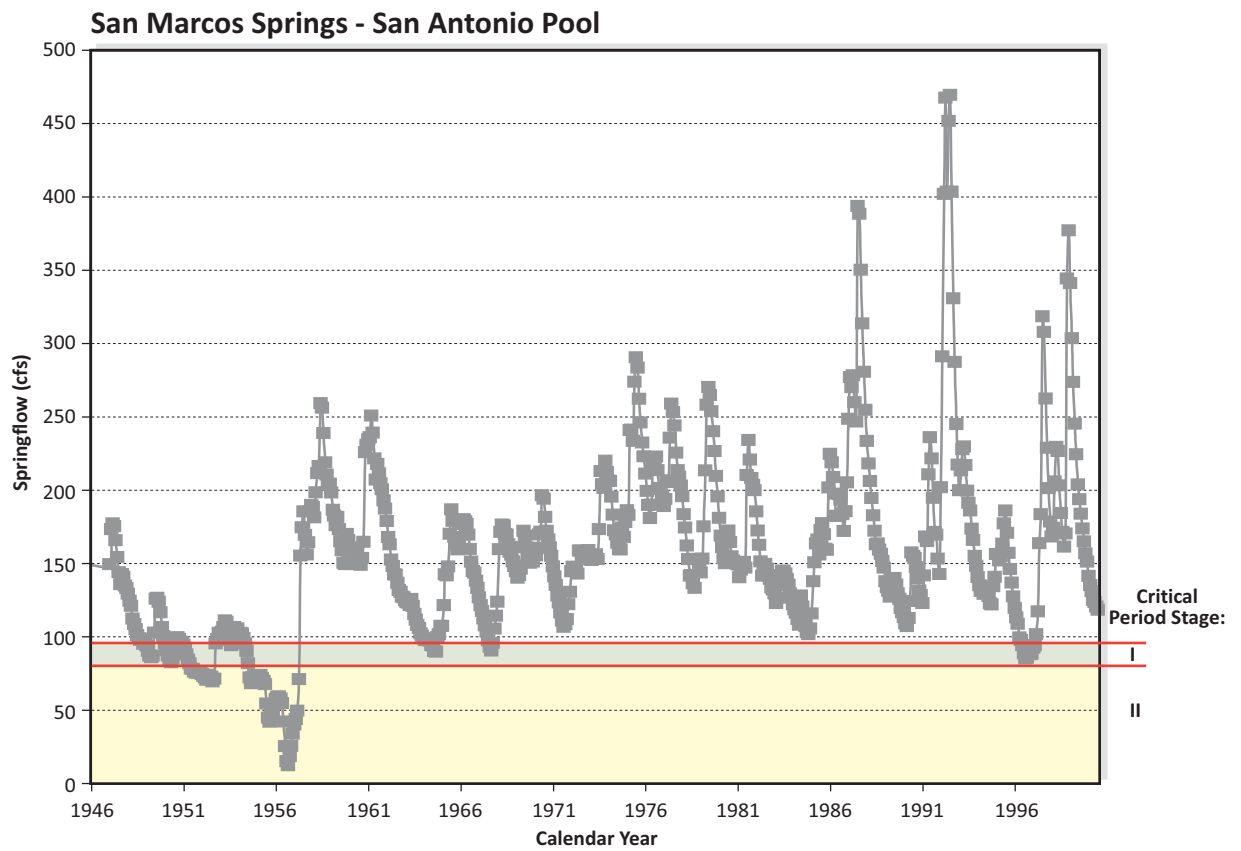
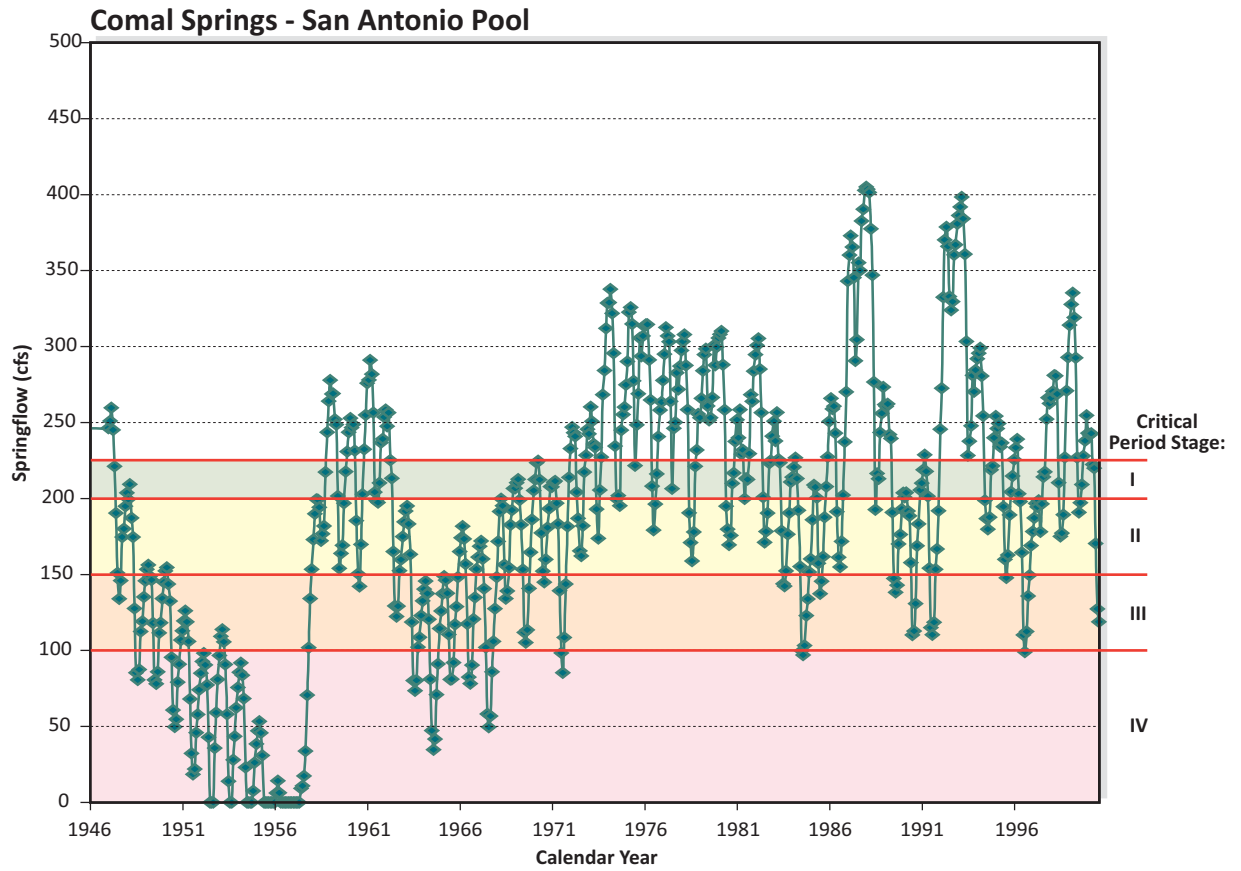

October 2008
TODD ENGINEERS
Alameda, California

Figure 3-3
Baseline Scenario
Comal and
San Marcos Springs

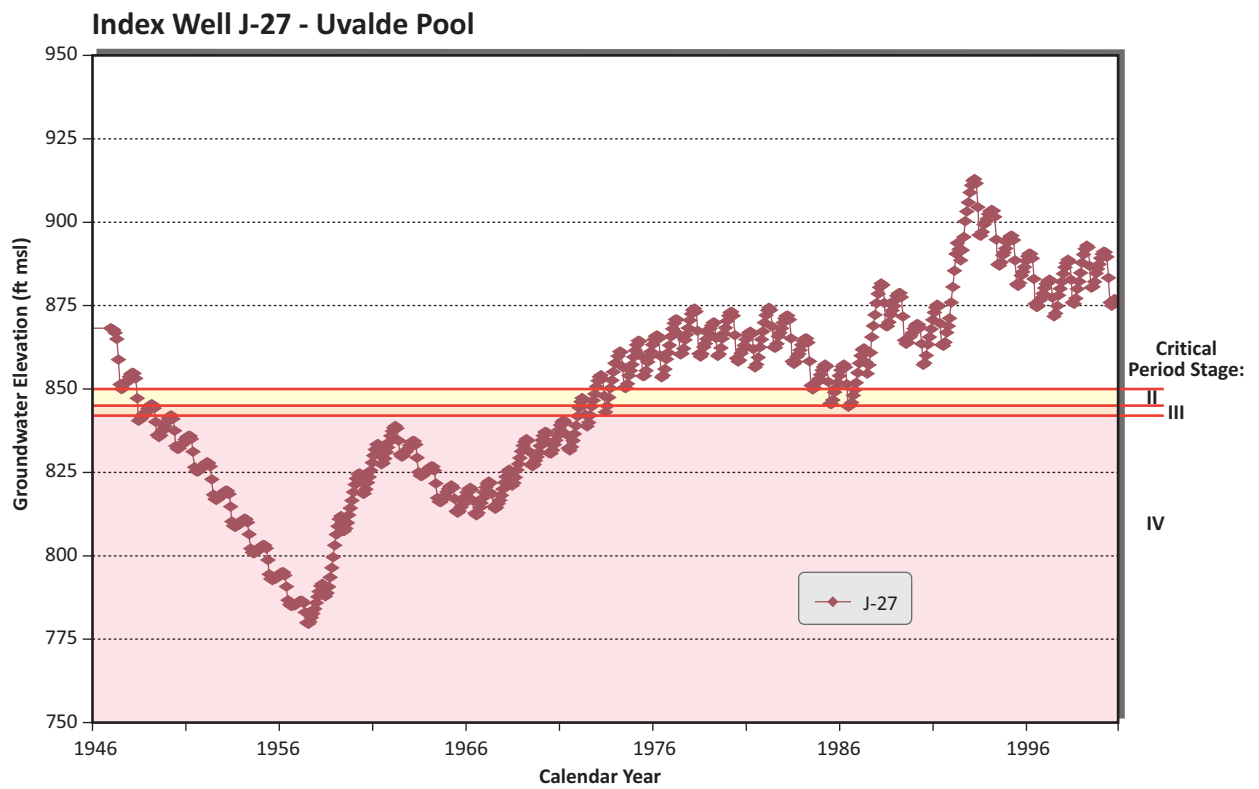
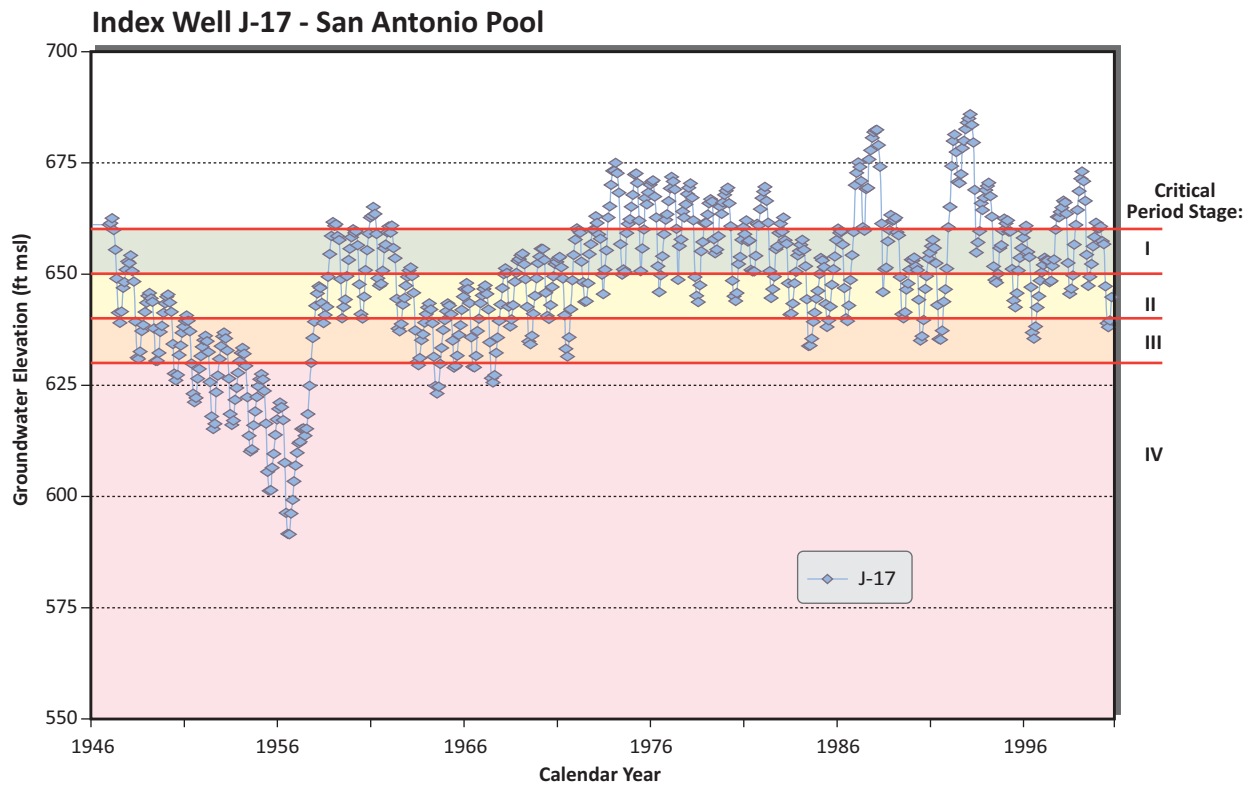

October 2008
 TODD ENGINEERS
 Alameda, California

Figure 3-4
Baseline Scenario
Water Levels in
J-17 and J-27

Recharge Slug 1947 - 25,000 AF

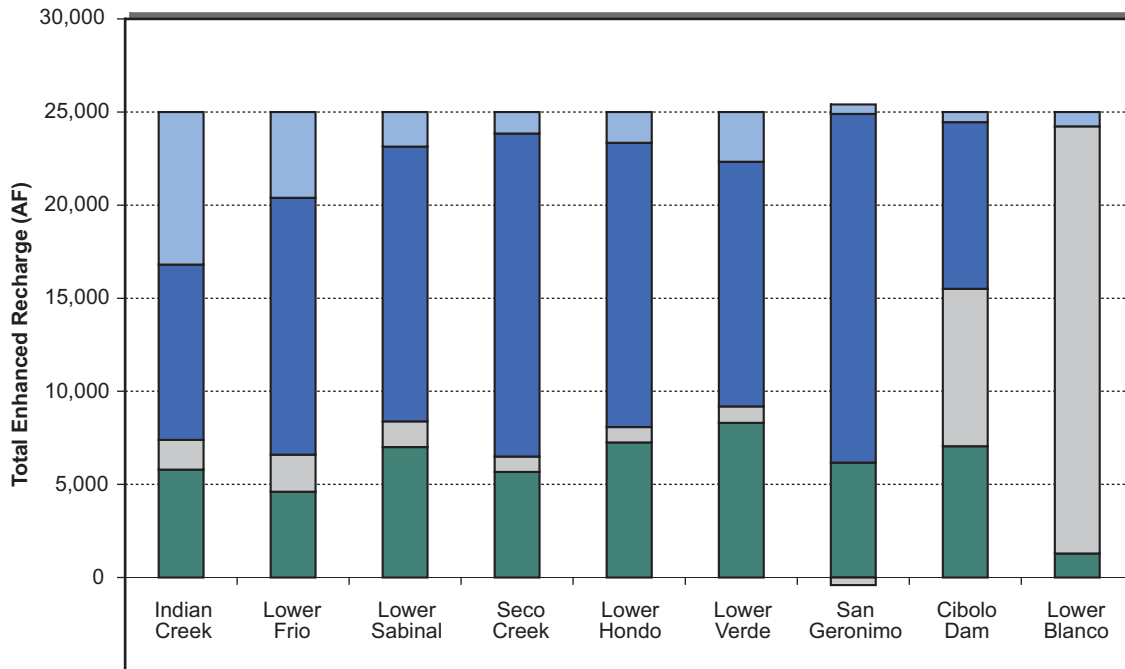

Recharge Slug 1974 - 25,000 AF

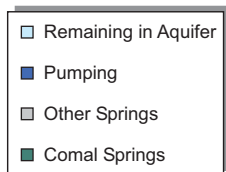
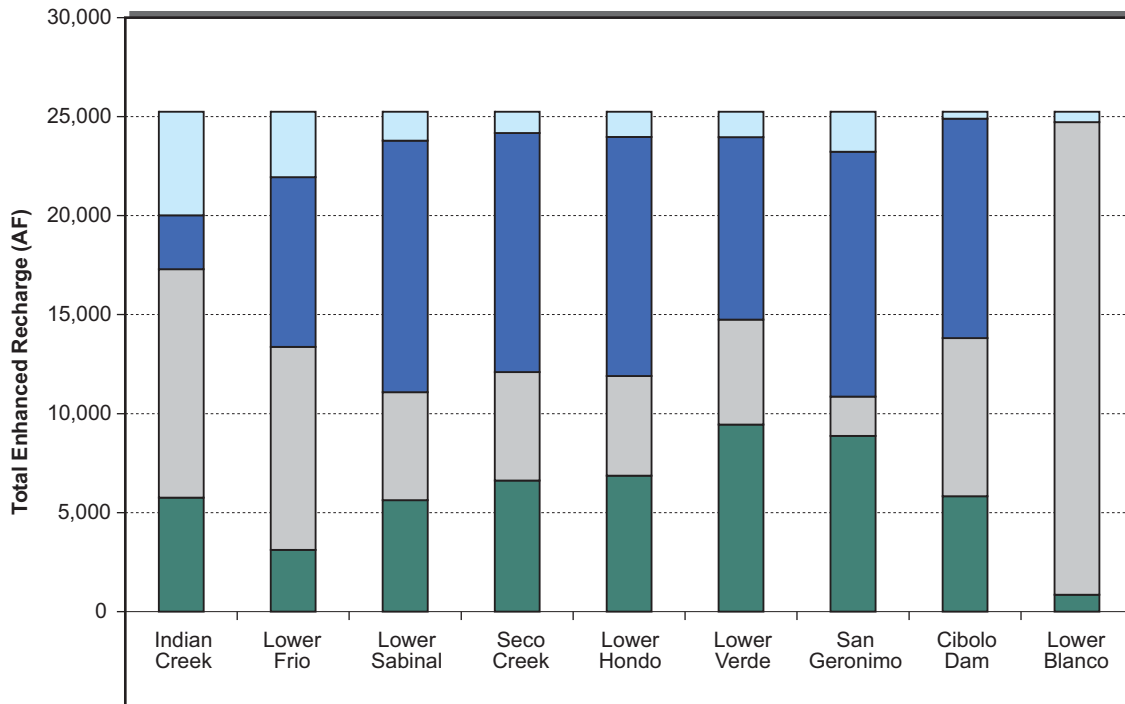

December 2008
 TODD ENGINEERS
 Alameda, California

Figure 4-1
Results of Slug
Recharge Analysis

Recharge Slug in 1947 - 25,000 AF

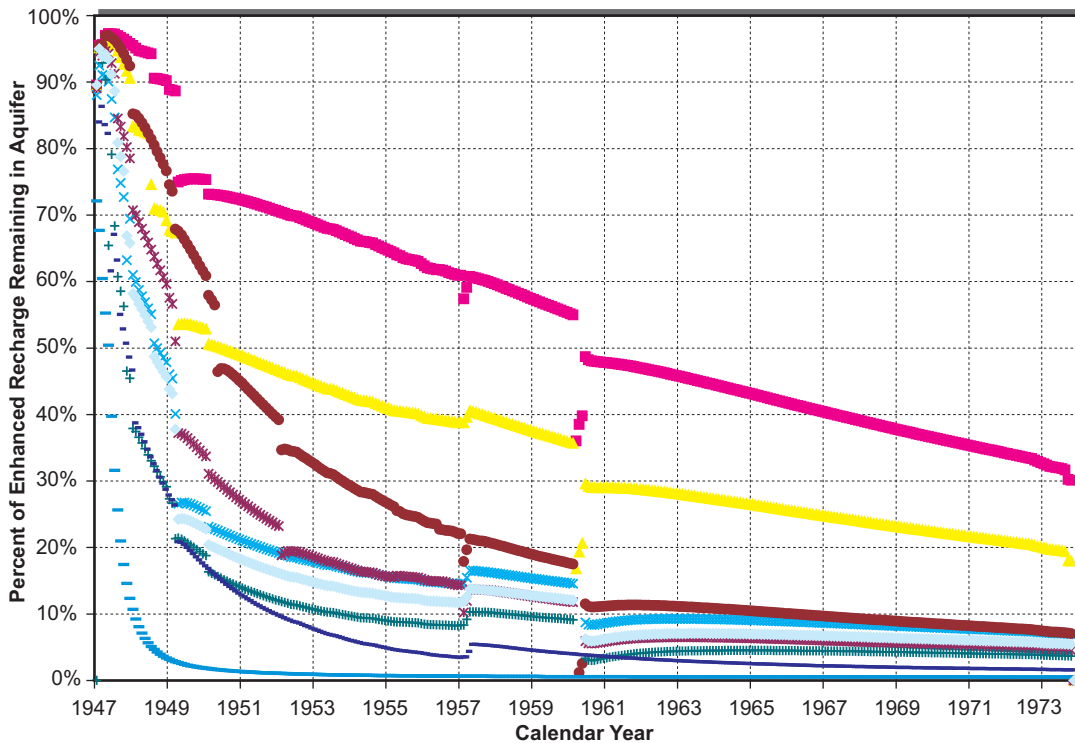

Recharge Slug in 1974 - 25,000 AF

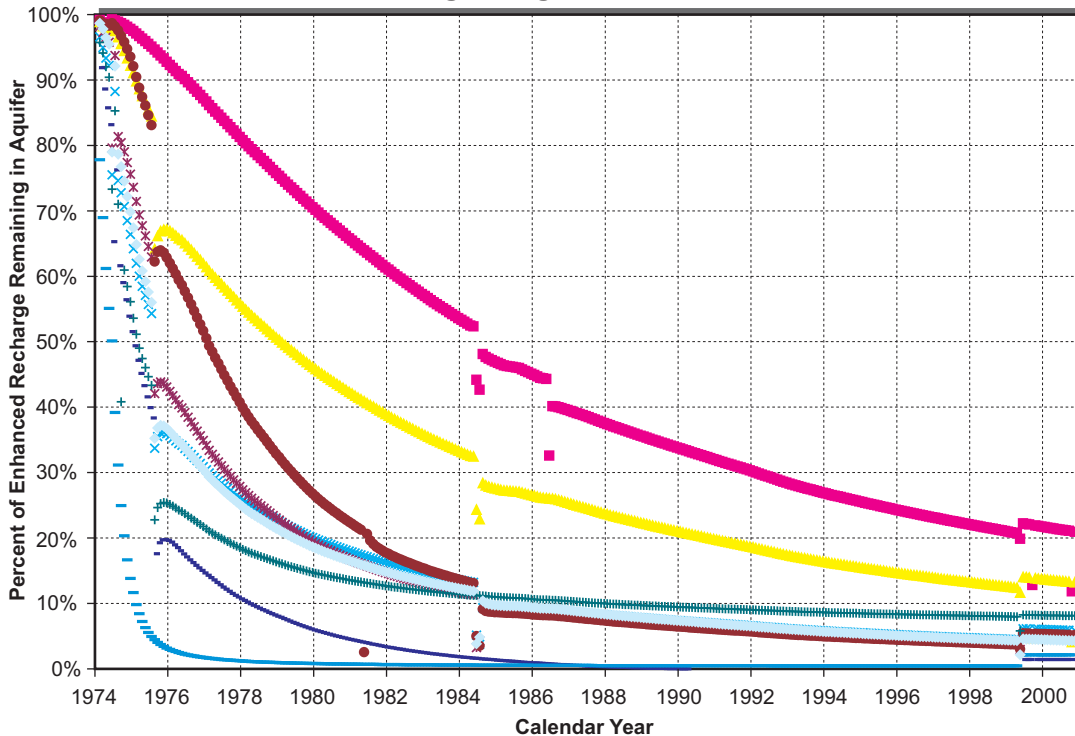

- Indian Creek
- ▲ Lower Frio
- × Lower Sabinal
- ◆ Seco Creek
- × Lower Hondo
- Lower Verde
- + San Geronimo
- Cibolo Dam
- Lower Blanco

October 2008
 TODD ENGINEERS
 Alameda, California

Figure 4-2
 Retention Time
 of
 Slug Recharge

Annual Recharge 25,000 AFY 1947 - 1973

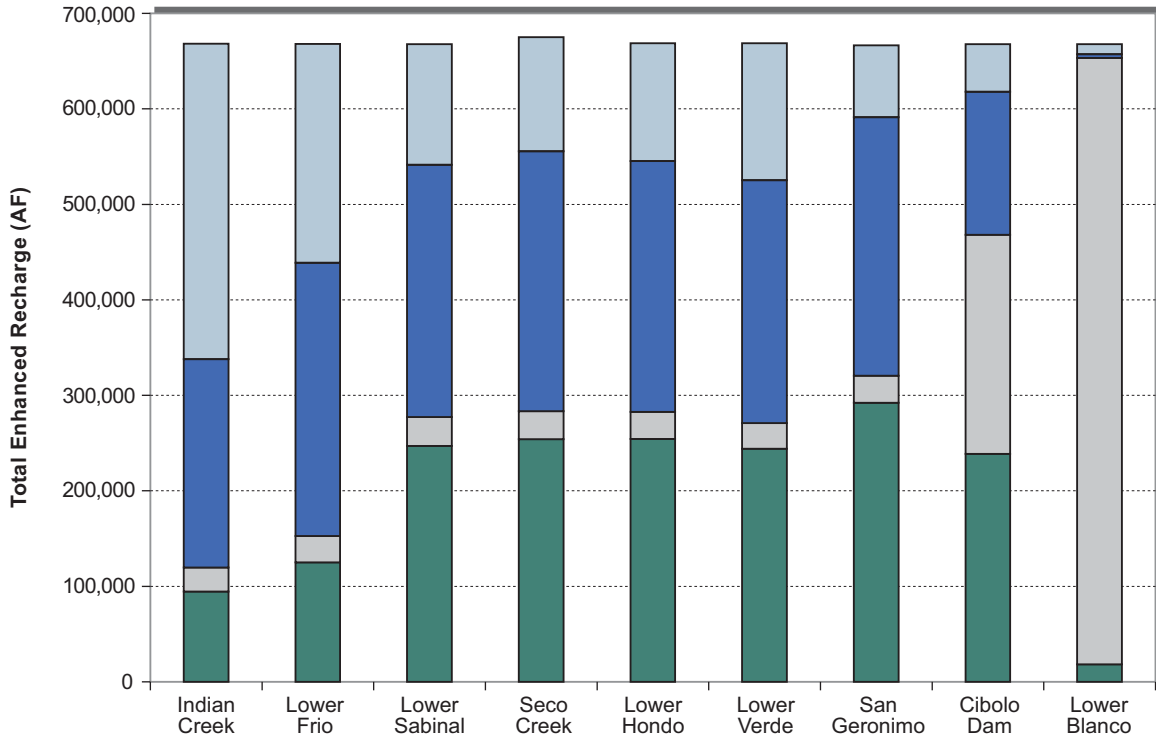

Annual Recharge 25,000 AFY 1974 - 2000

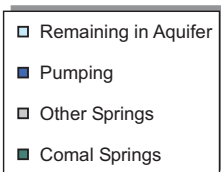
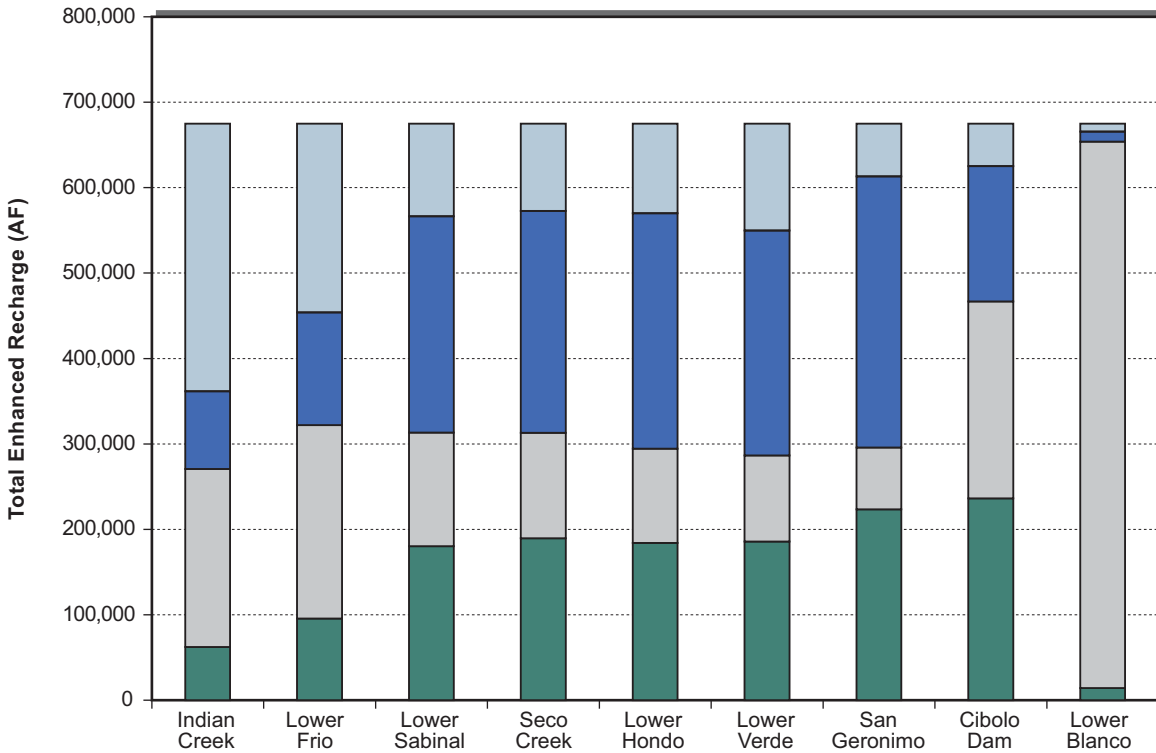

October 2008
TODD ENGINEERS
 Alameda, California

Figure 4-3
Results of
25,000 AFY Annual
Recharge

Annual Recharge - 25,000 AFY 1947 - 1973

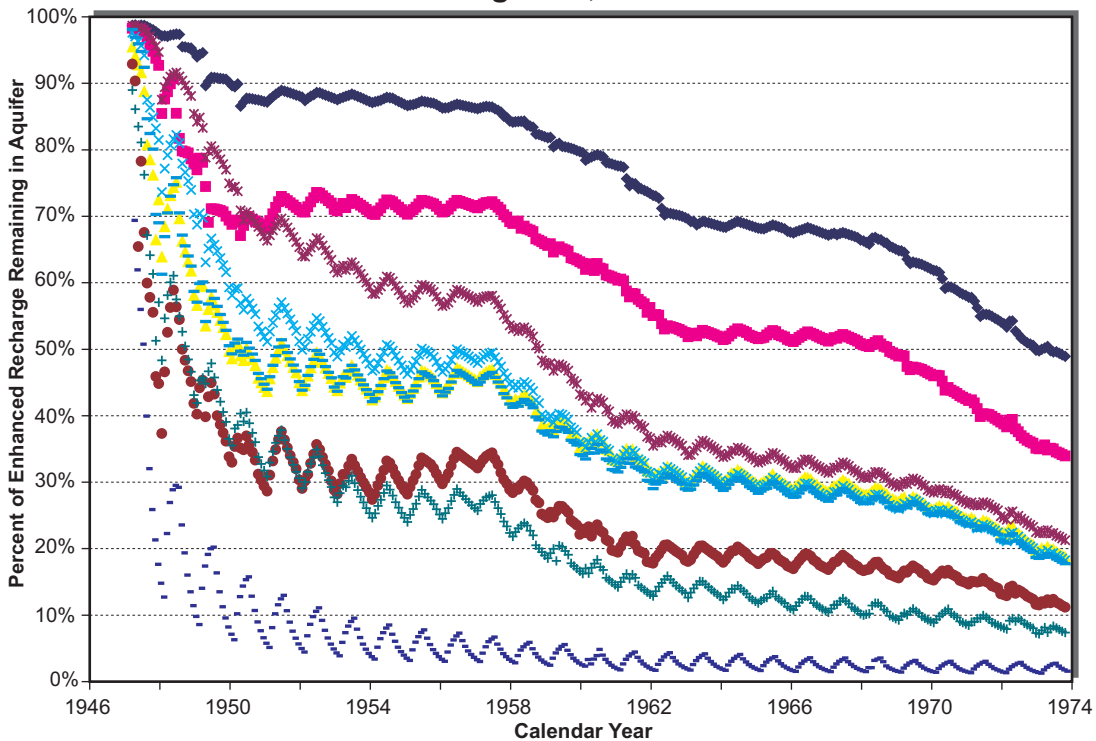

Annual Recharge - 25,000 AFY 1974 - 2000

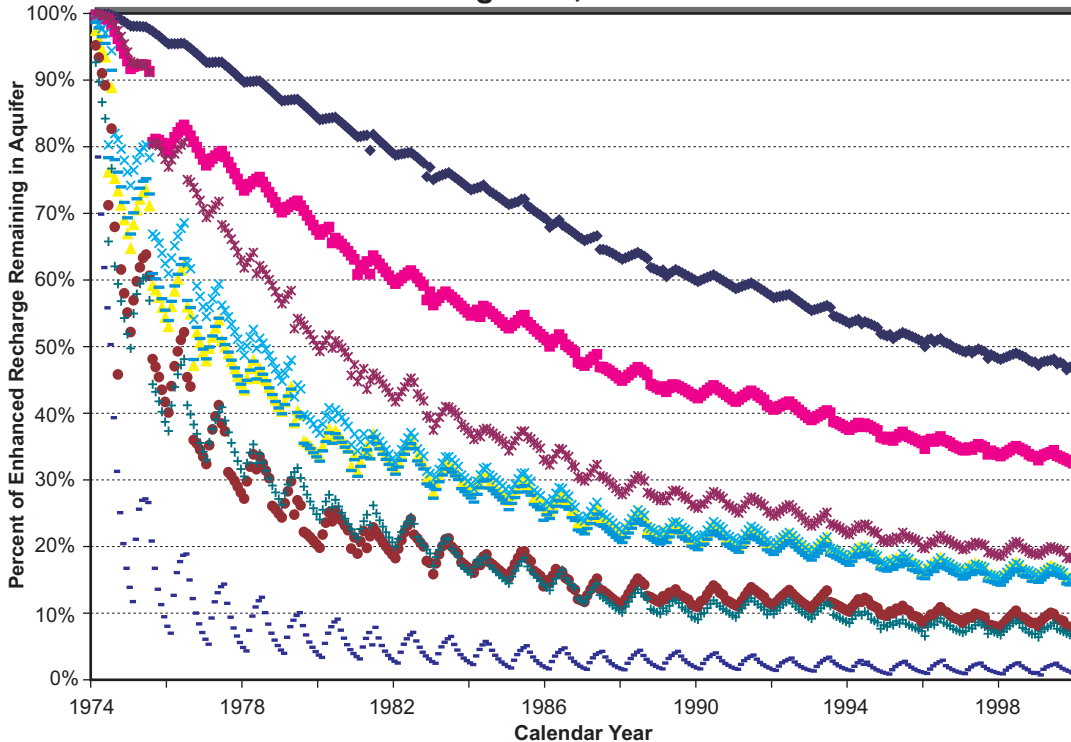

- ◆ Indian Creek
- Lower Frio
- ▲ Lower Sabinal
- Seco Creek
- × Lower Hondo
- × Lower Verde
- San Geronimo
- + Cibolo Dam
- Lower Blanco

October 2008

TODD ENGINEERS
Alameda, California

Figure 4-4
Retention Time
of
Annual Recharge

Maintaining Springflow >40 cfs 1947 - 1973

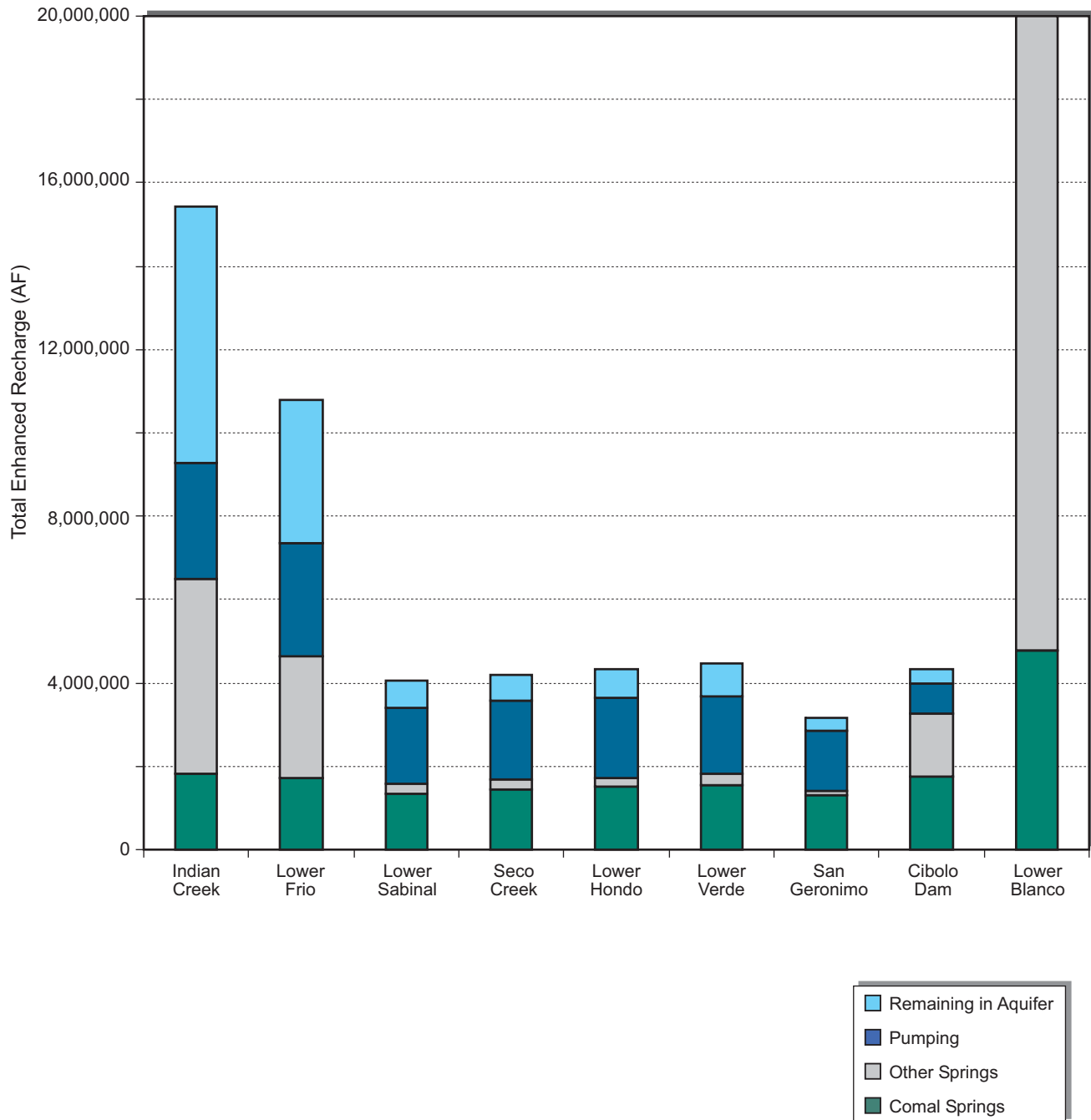

December 2008
 TODD ENGINEERS
 Alameda, California

Figure 4-5
Enhanced Recharge
Required for Minimum
Springflow of 40 cfs for
Dry Conditions

Maintaining Springflow >150 cfs 1947 - 1973

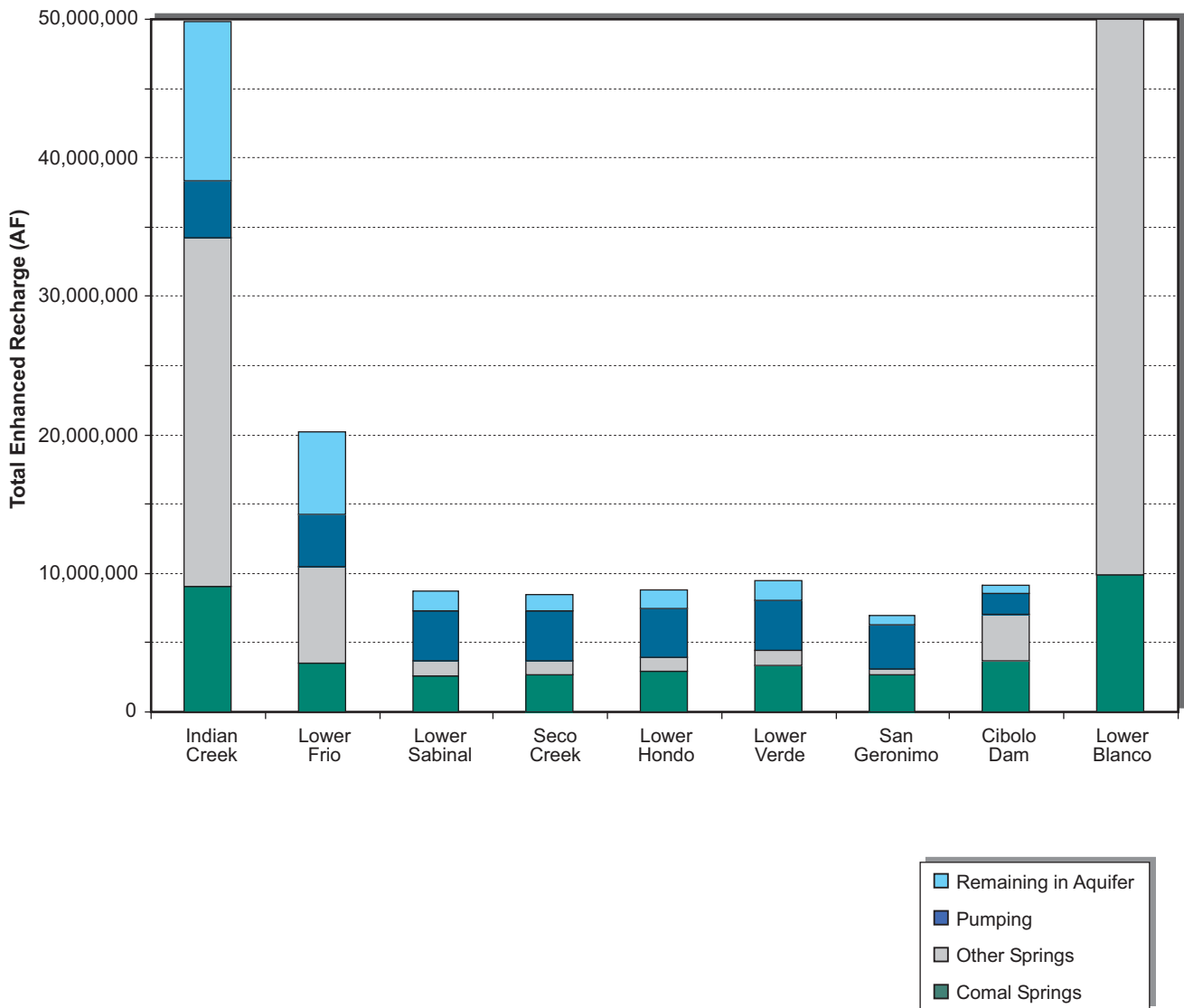

October 2008

TODD ENGINEERS
Alameda, California

Figure 4-6
Enhanced Recharge
Required for Minimum
Springflow of 150 cfs for
Dry Conditions

Maintaining Springflow >150 cfs 1974 - 2000

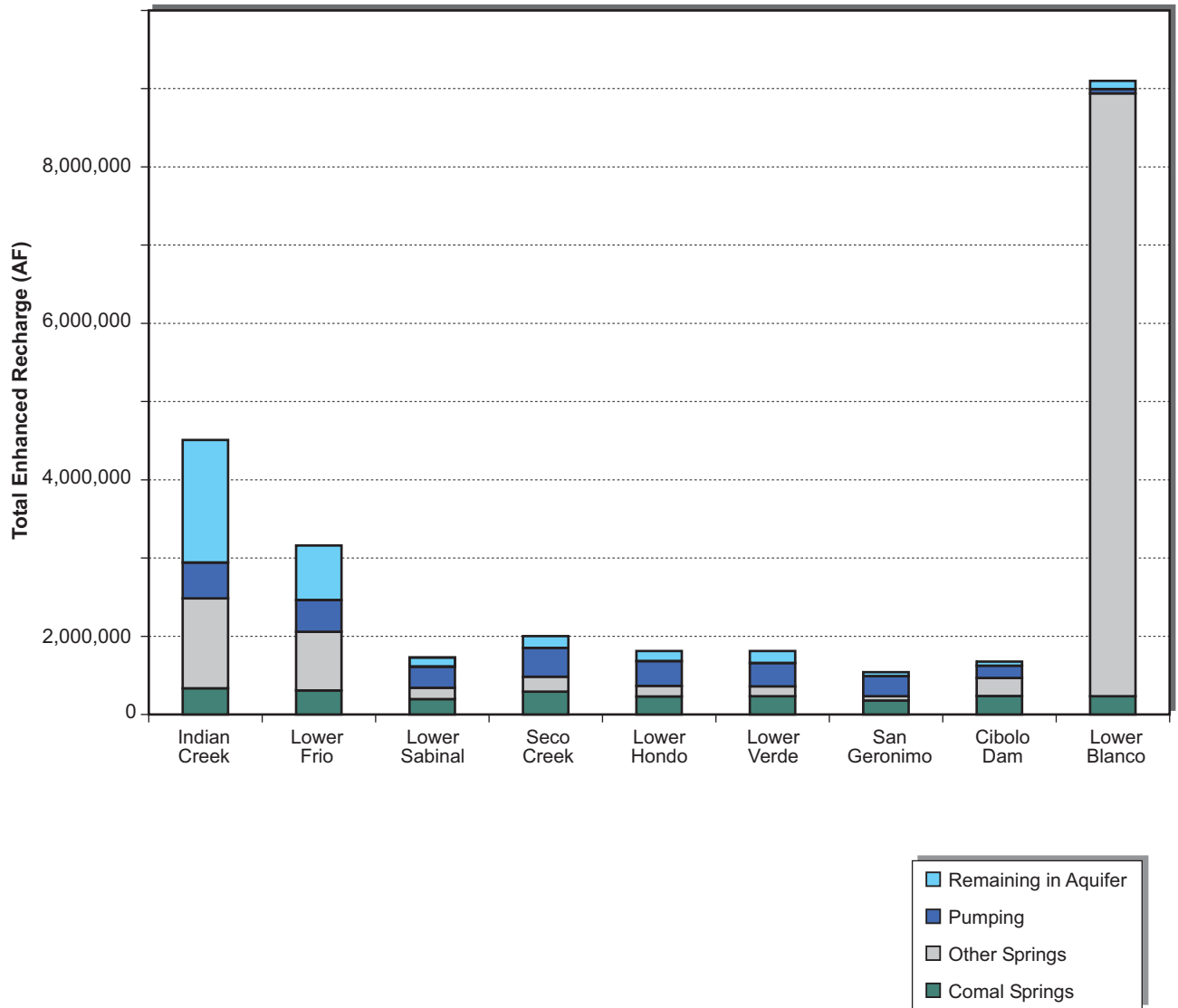

October 2008
 TODD ENGINEERS
 Alameda, California

Figure 4-7
Enhanced Recharge
Required for Minimum
Springflow of 150 cfs for
Average Conditions

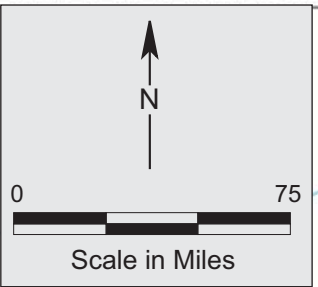
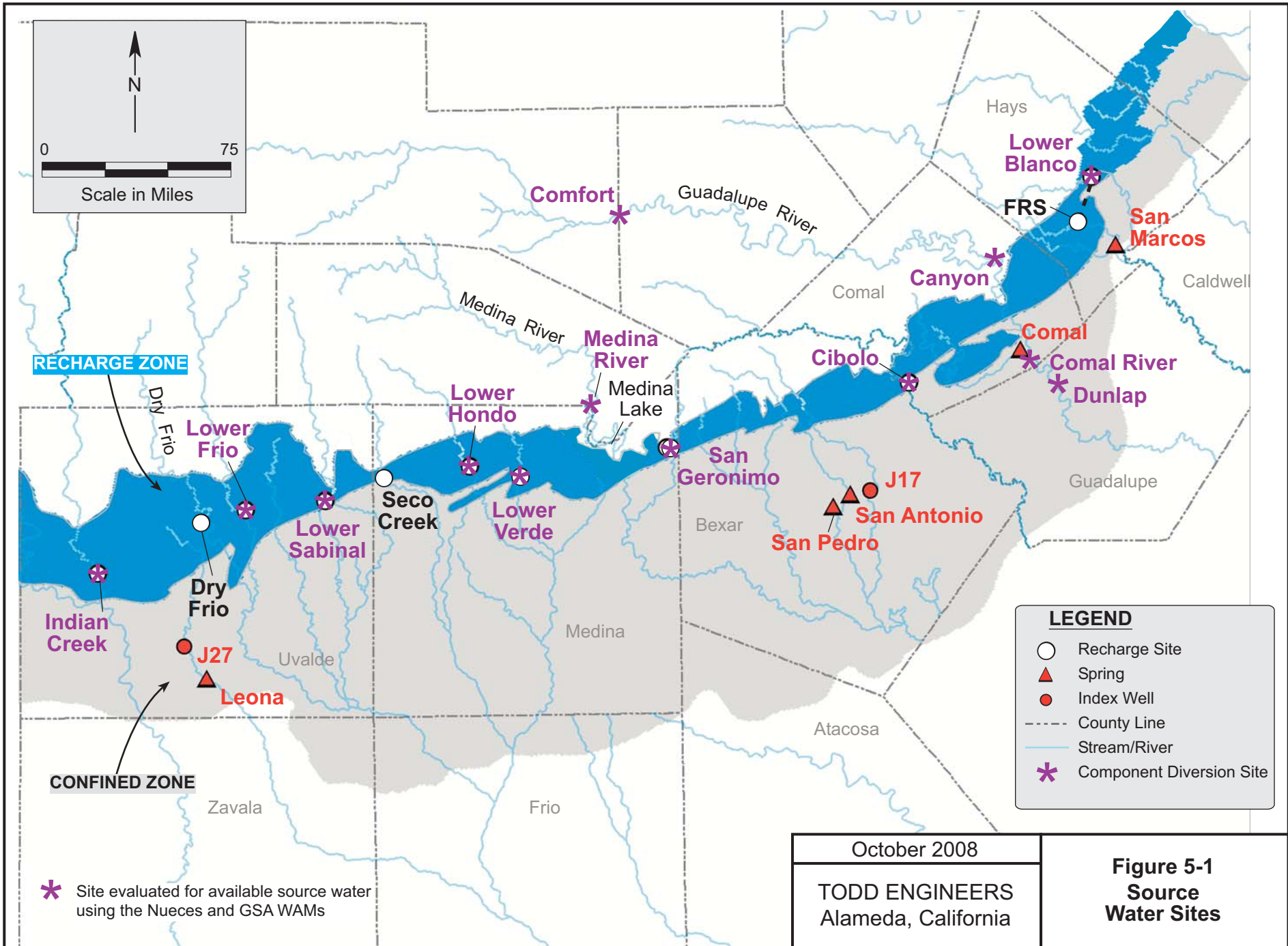

RECHARGE ZONE

CONFINED ZONE

* Site evaluated for available source water using the Nueces and GSA WAMs

LEGEND

- Recharge Site
- ▲ Spring
- Index Well
- - - County Line
- Stream/River
- * Component Diversion Site

October 2008
 TODD ENGINEERS
 Alameda, California

Figure 5-1
Source
Water Sites

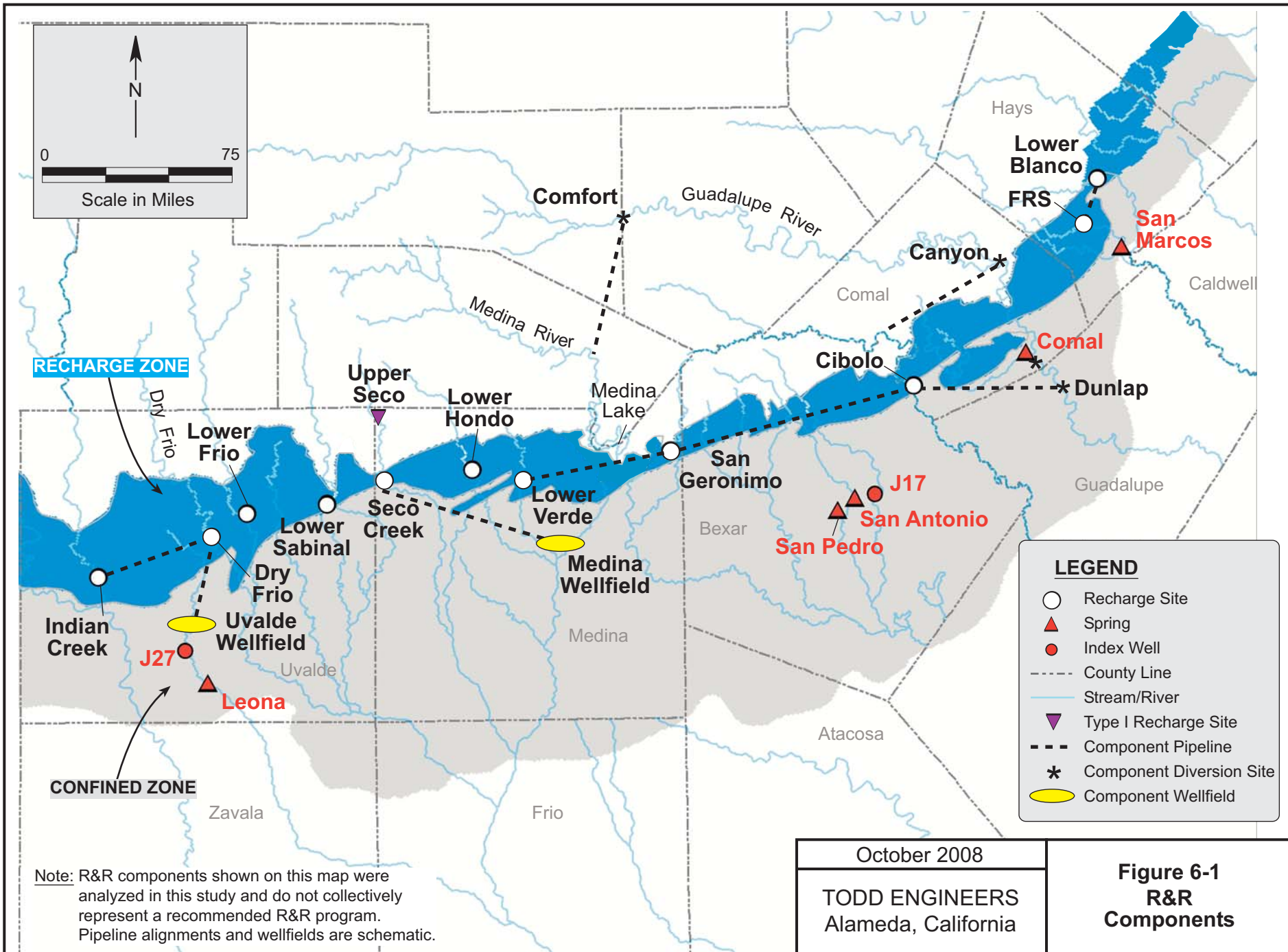

Note: R&R components shown on this map were analyzed in this study and do not collectively represent a recommended R&R program. Pipeline alignments and wellfields are schematic.

October 2008
 TODD ENGINEERS
 Alameda, California

Figure 6-1
R&R
Components

Unappropriated Water at Lake Dunlap R&R Site

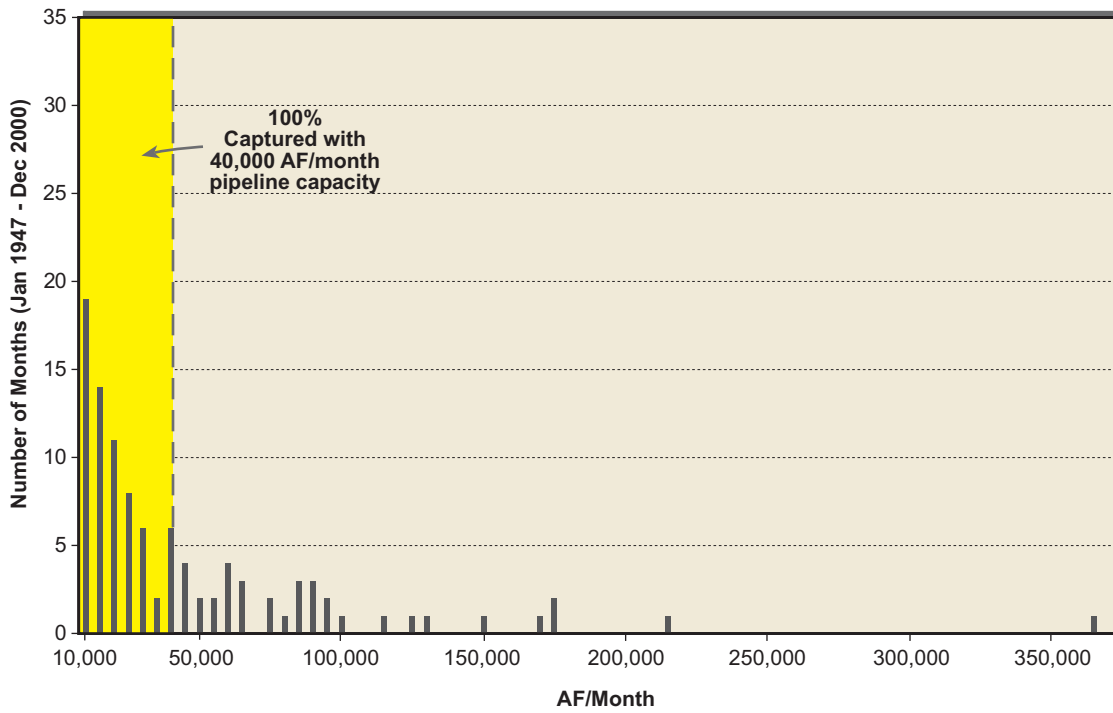

Unappropriated Water at Canyon Lake R&R Site

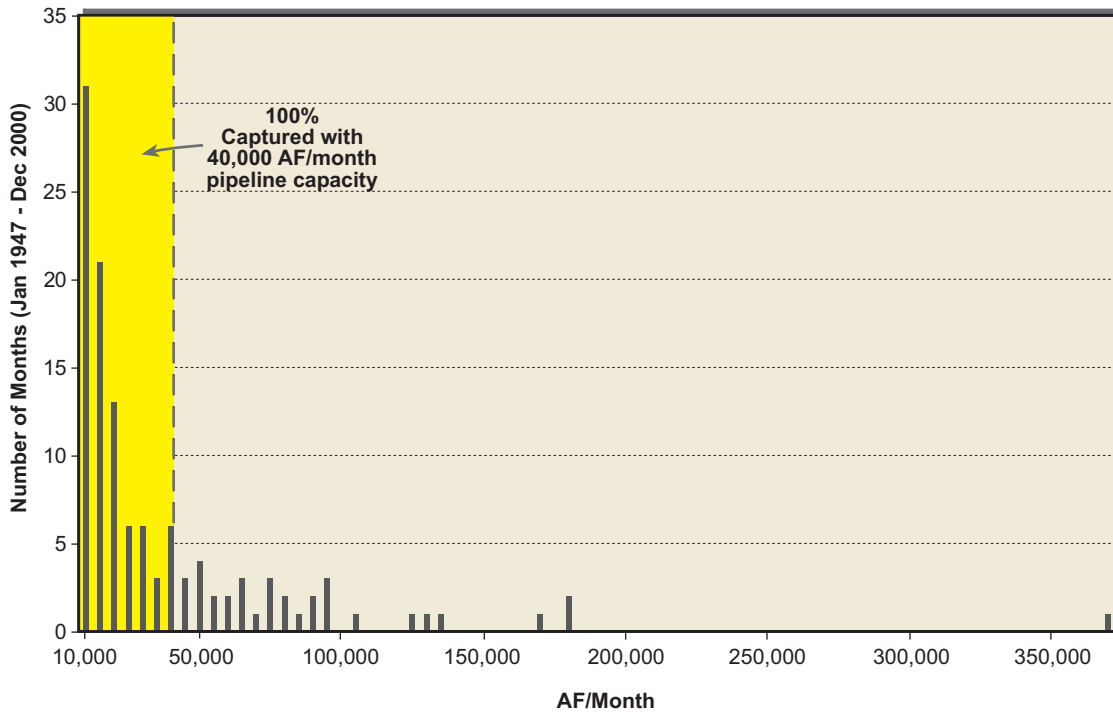

Note: First bar includes monthly amounts from 5,000 AF/month to 10,000 AF/month. Monthly amounts less than 5,000 AF/month are not shown. Monthly amounts greater than pipeline capacity were capped at capacity.

October 2008
 TODD ENGINEERS
 Alameda, California

Figure 6-2
Histograms of the
Unappropriated
Water at Dunlap and
Canyon Sites

Unappropriated Water at R&R Site near Comfort

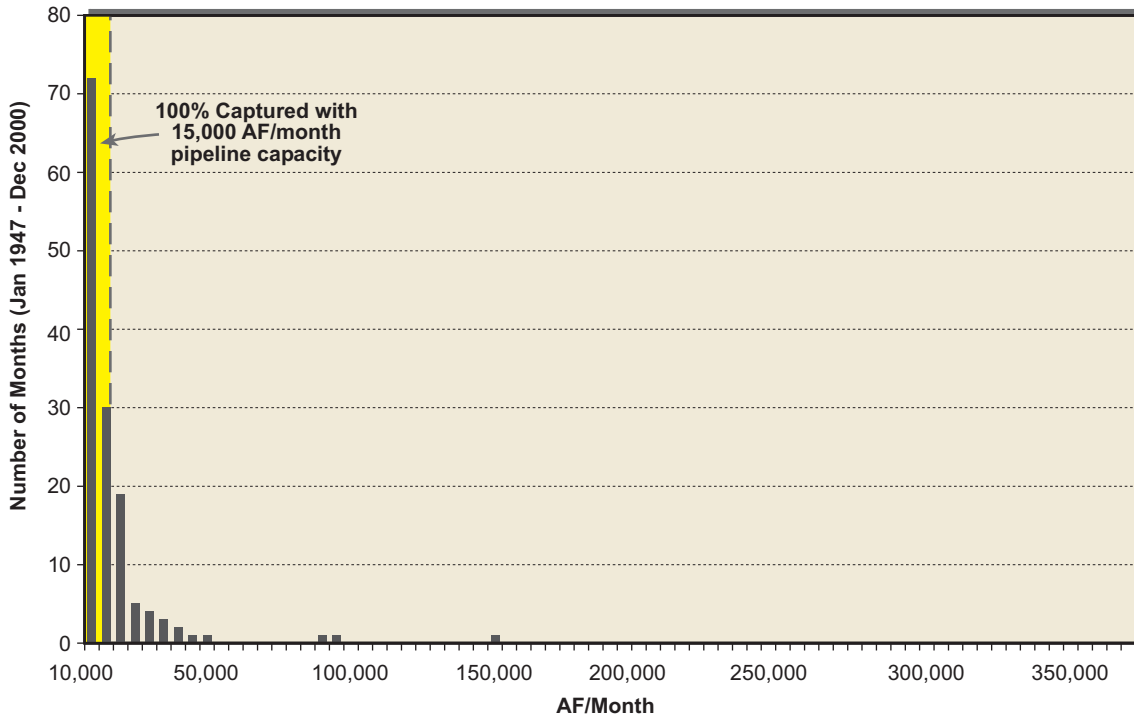

Unappropriated Water at Comfort and Medina River R&R Sites

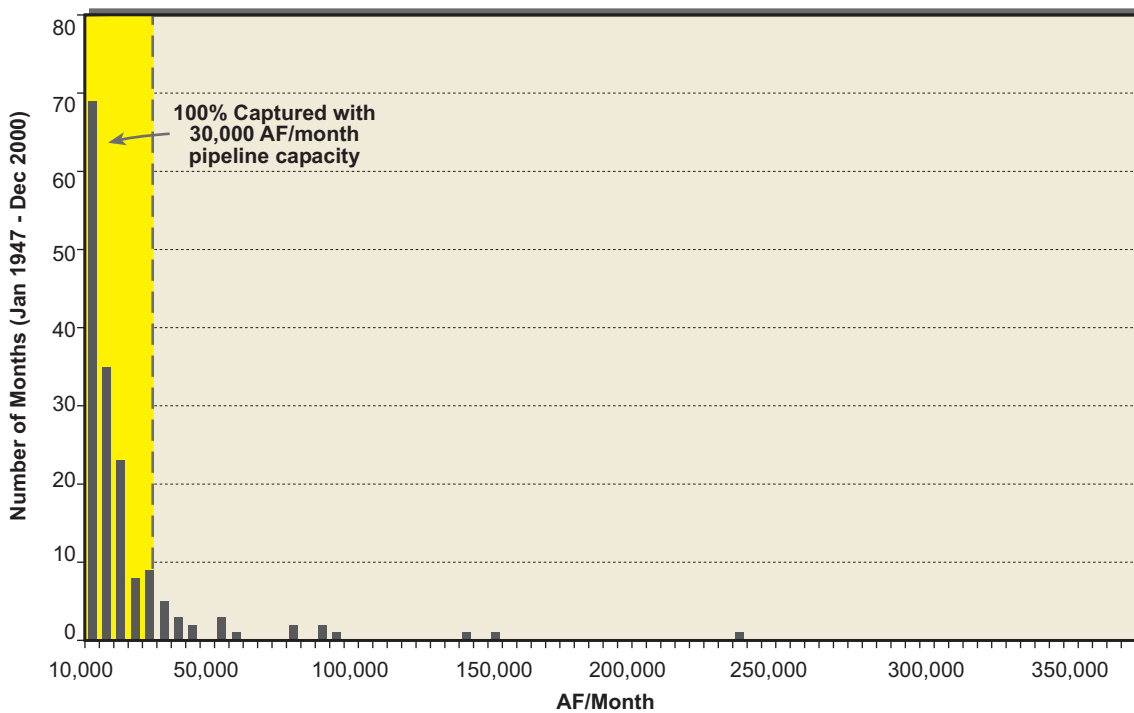

Note: First bar includes monthly amounts from 5,000 AF/month to 10,000 AF/month. Monthly amounts less than 5,000 AF/month are not shown. Monthly amounts greater than pipeline capacity were capped at capacity.

October 2008
 TODD ENGINEERS
 Alameda, California

Figure 6-3
Histograms of the
Unappropriated Water
at Comfort and
Medina River

Combined Unappropriated/Marketable Water at Type 2 R&R Sites

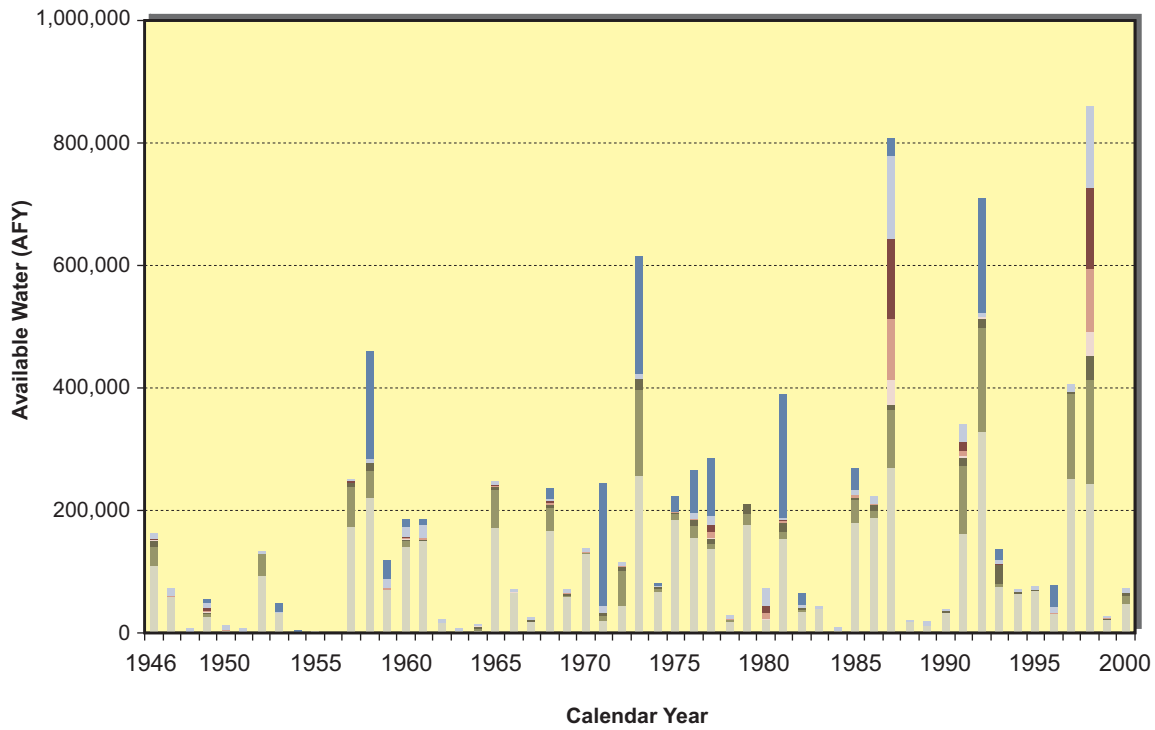

Unappropriated Water at Type 2 R&R Sites

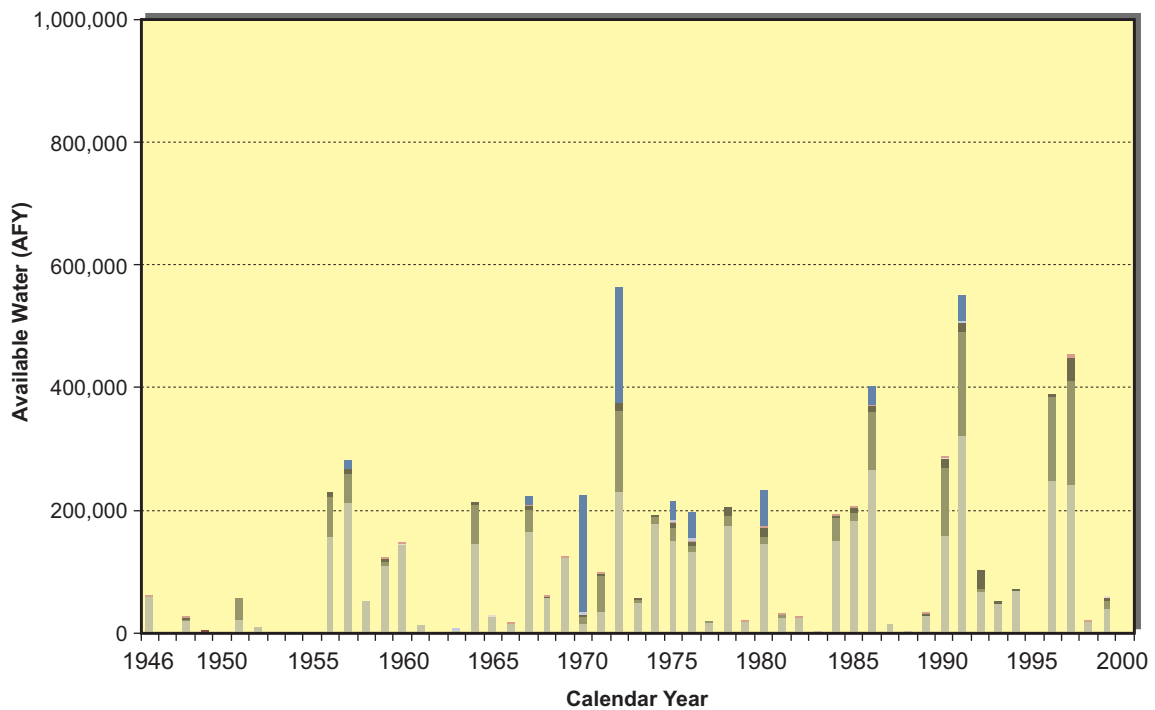

- Indian Creek
- Lower Frio
- Lower Sabinal
- Lower Hondo
- Lower Verde
- San Geronimo
- Cibolo Dam
- Lower Blanco

October 2008
 TODD ENGINEERS
 Alameda, California

Figure 6-4
Unappropriated and
Marketable Water for Type 2
R&R Sites

Unappropriated Water at the Central Type 2 R&R Sites

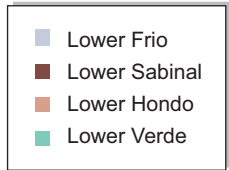
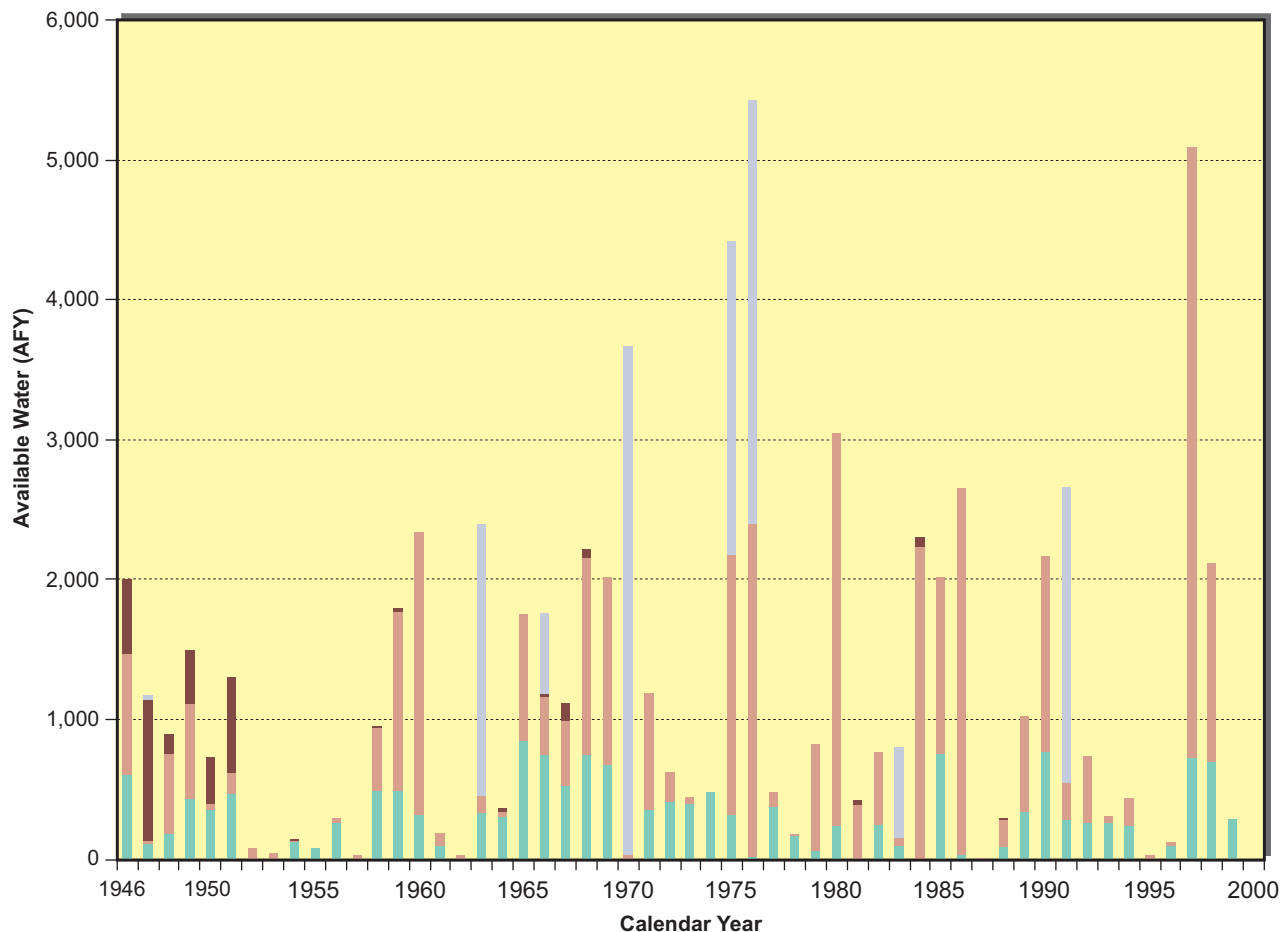

December 2008
 TODD ENGINEERS
 Alameda, California

Figure 6-5
Unappropriated
Water for the
Central Type 2 Sites
(Lower Frio to Lower Verde)

**Enhanced Recharge with Maximum Source Water
at each Type 2 Site 1947 - 1973**

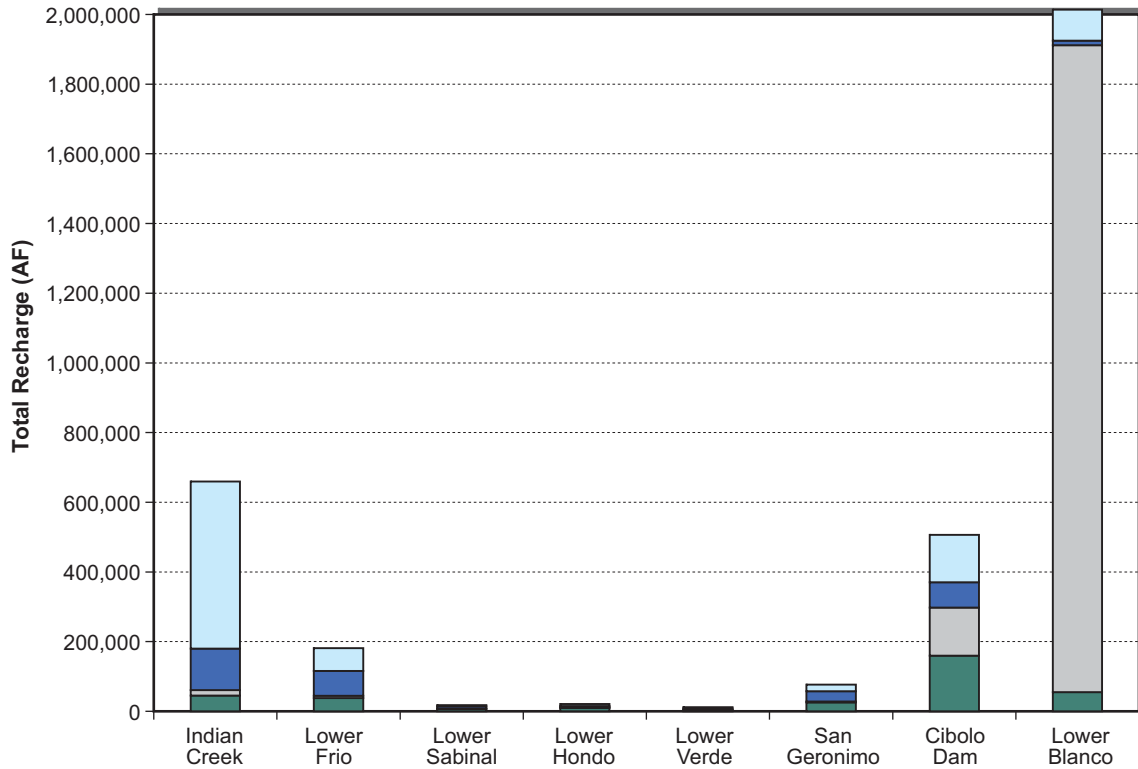

**Enhanced Recharge with Maximum Source Water
at each Type 2 Site 1974 - 2000**

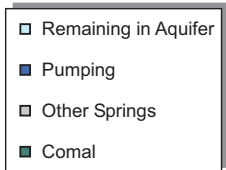
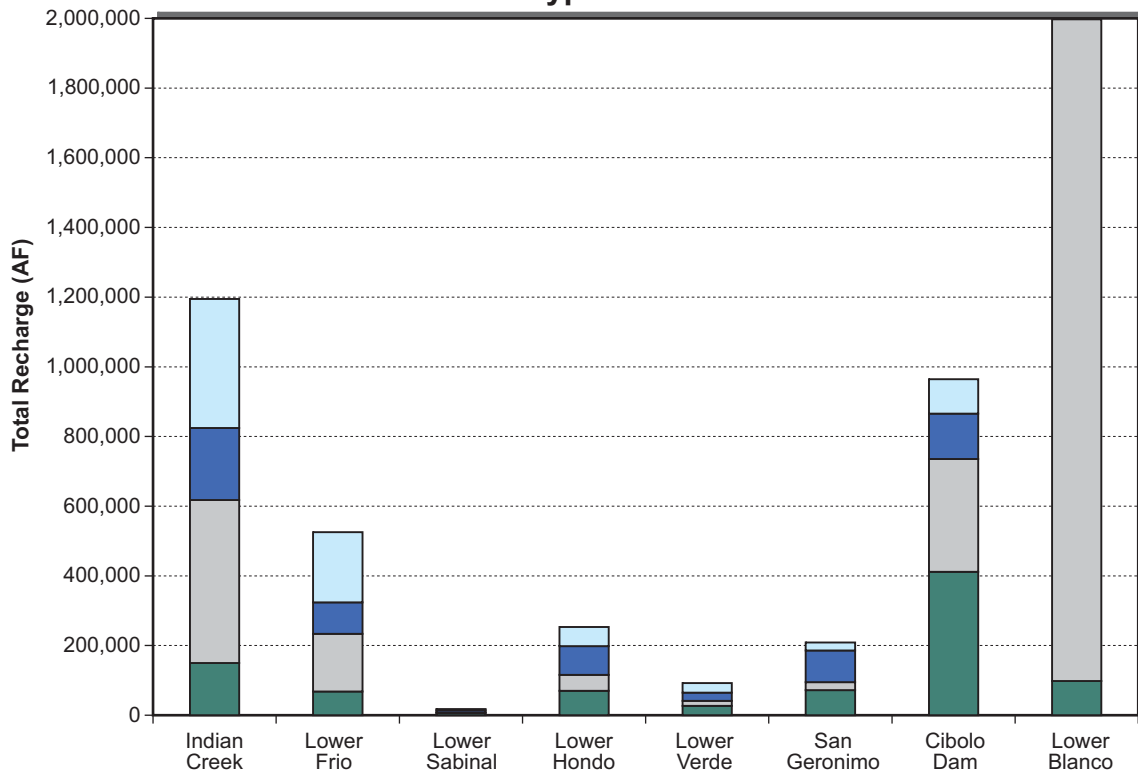

October 2008
TODD ENGINEERS
Alameda, California

**Figure 6-6
Total Yield From Type 2
Enhanced Recharge
(Maximum Available
Source Water)**

Enhanced Recharge with Unappropriated Source Water at each Type 2 Site 1947 - 1973

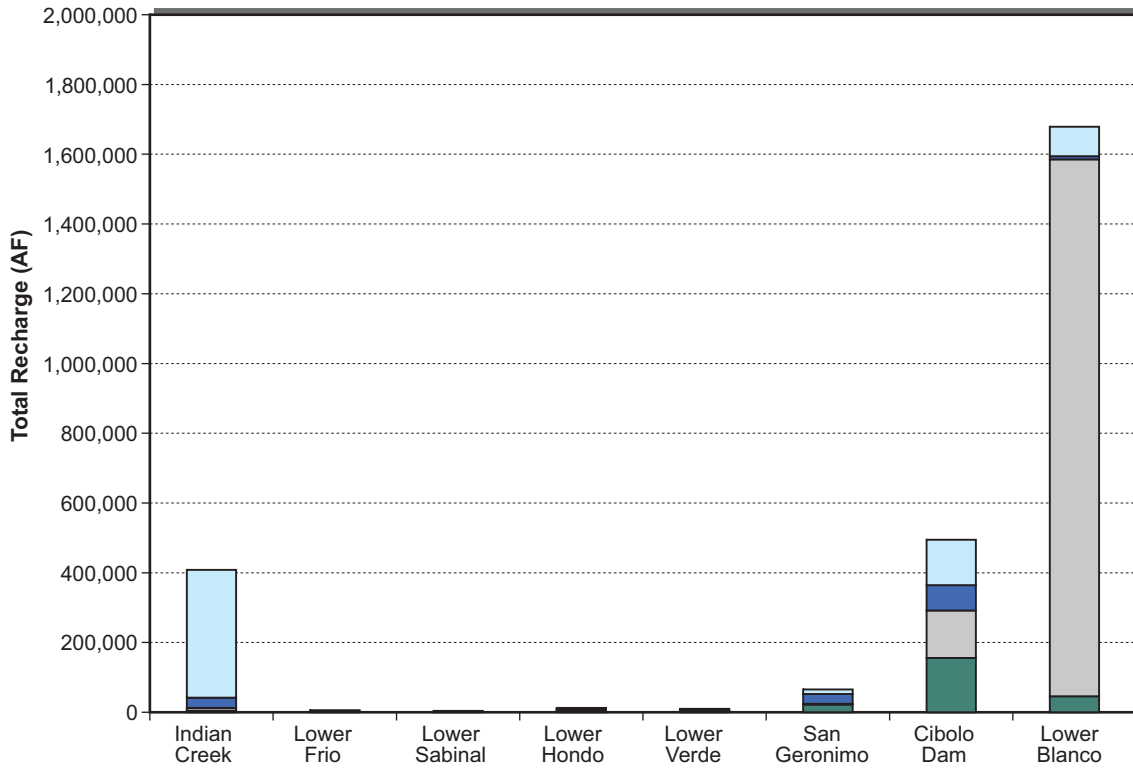

Enhanced Recharge with Unappropriated Source Water at each Type 2 Site 1974 - 2000

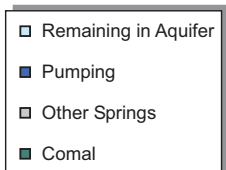
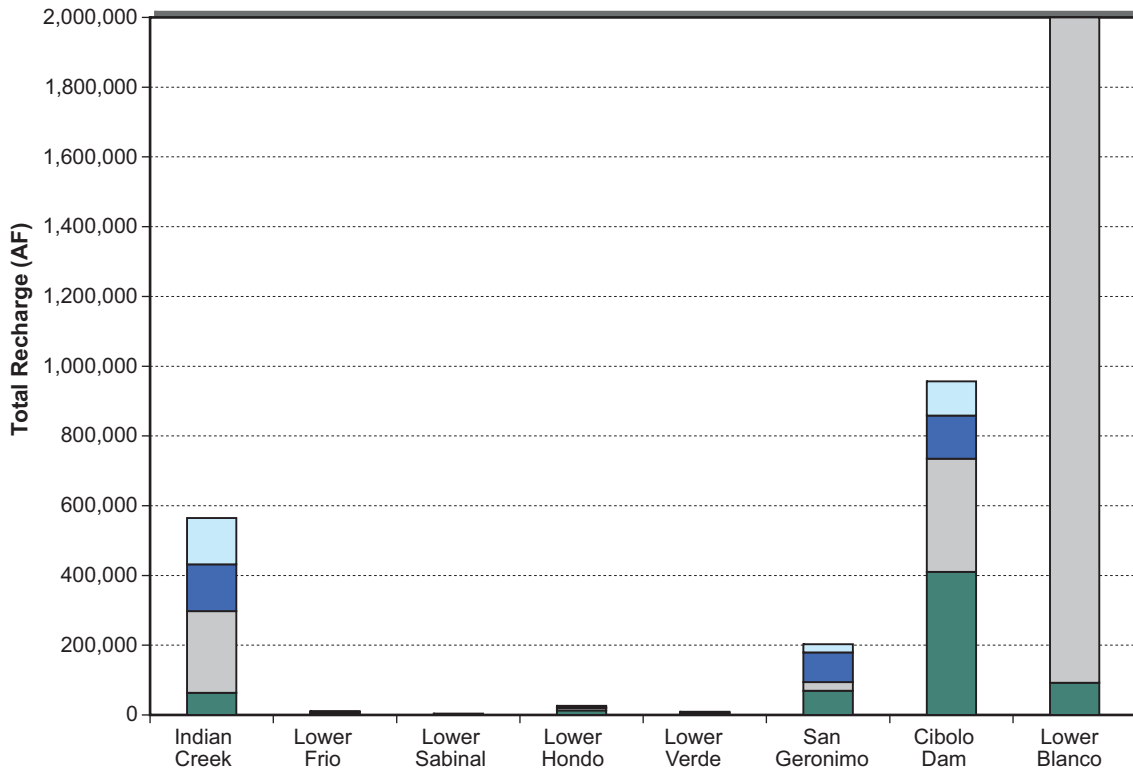

October 2008
TODD ENGINEERS
Alameda, California

Figure 6-7
Total Yield From
Type 2 Enhanced
Recharge
(Unappropriated Water)

Enhanced Recharge in Aquifer Storage at Indian Creek Type 2 Site

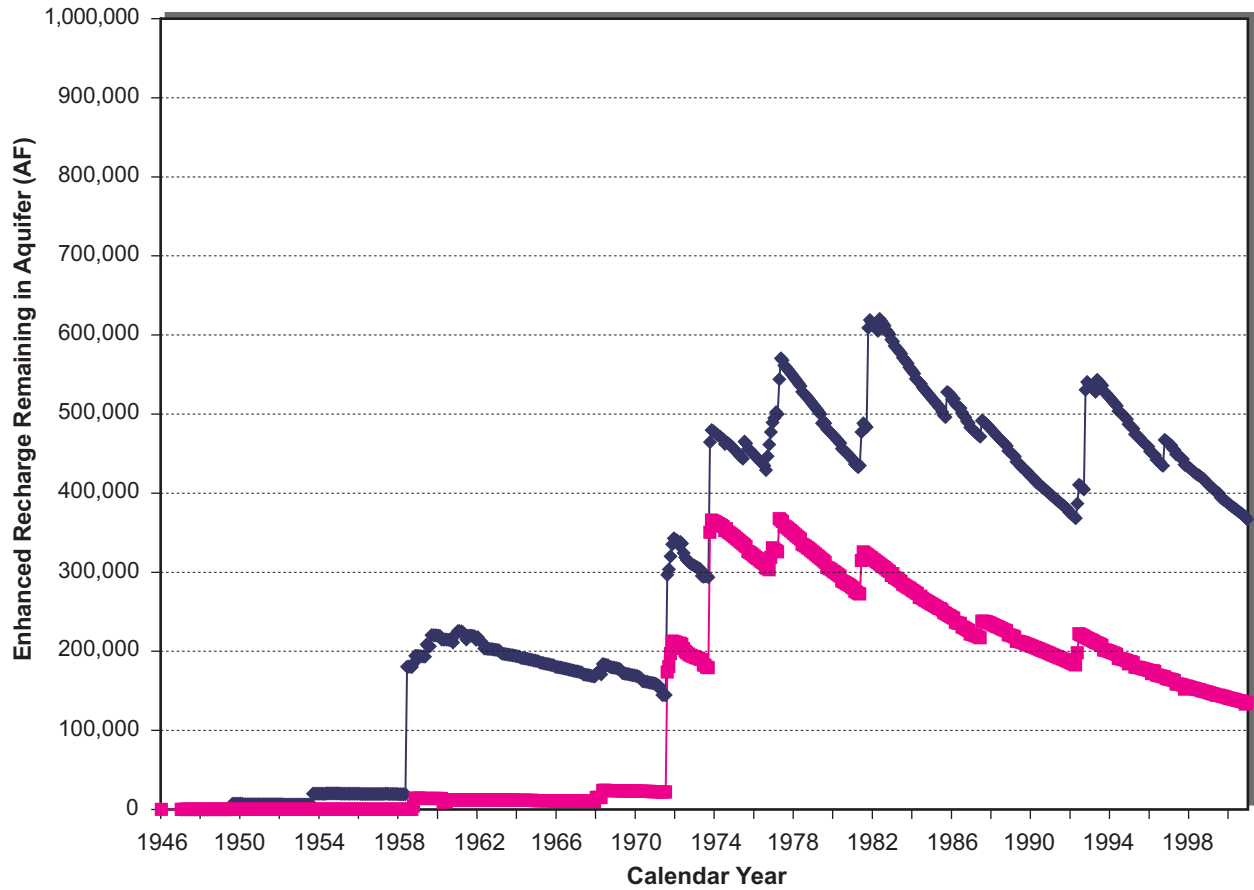

◆ Maximum (unappropriated and marketable)
■ Unappropriated

Note: Graphs 6-8 through 6-15 are conceptual analyses of source water impacts on aquifer storage at Type 2 locations and are conducted independent of actual site limitations to recharge.

December 2008	Figure 6-8 Recharge Remaining in the Aquifer over Time, Indian Creek
TODD ENGINEERS Alameda, California	

Enhanced Recharge in Aquifer Storage at Lower Frio Type 2 Site

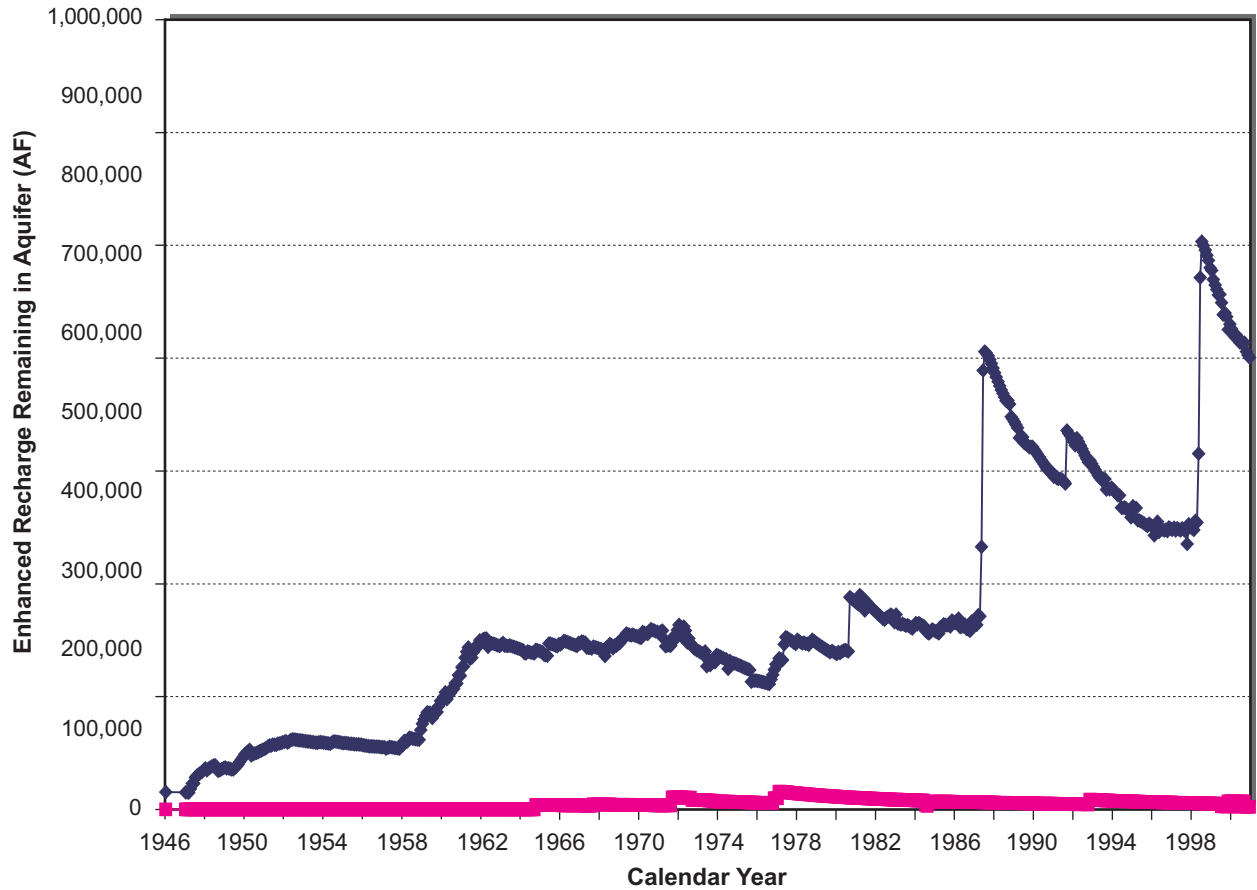

◆ Maximum (unappropriated and marketable)
■ Unappropriated

Note: Graphs 6-8 through 6-15 are conceptual analyses of source water impacts on aquifer storage at Type 2 locations and are conducted independent of actual site limitations to recharge.

December 2008	Figure 6-9 Recharge Remaining in the Aquifer over Time, Lower Frio
TODD ENGINEERS Alameda, California	

Enhanced Recharge in Aquifer Storage at Lower Sabinal Type 2 Site

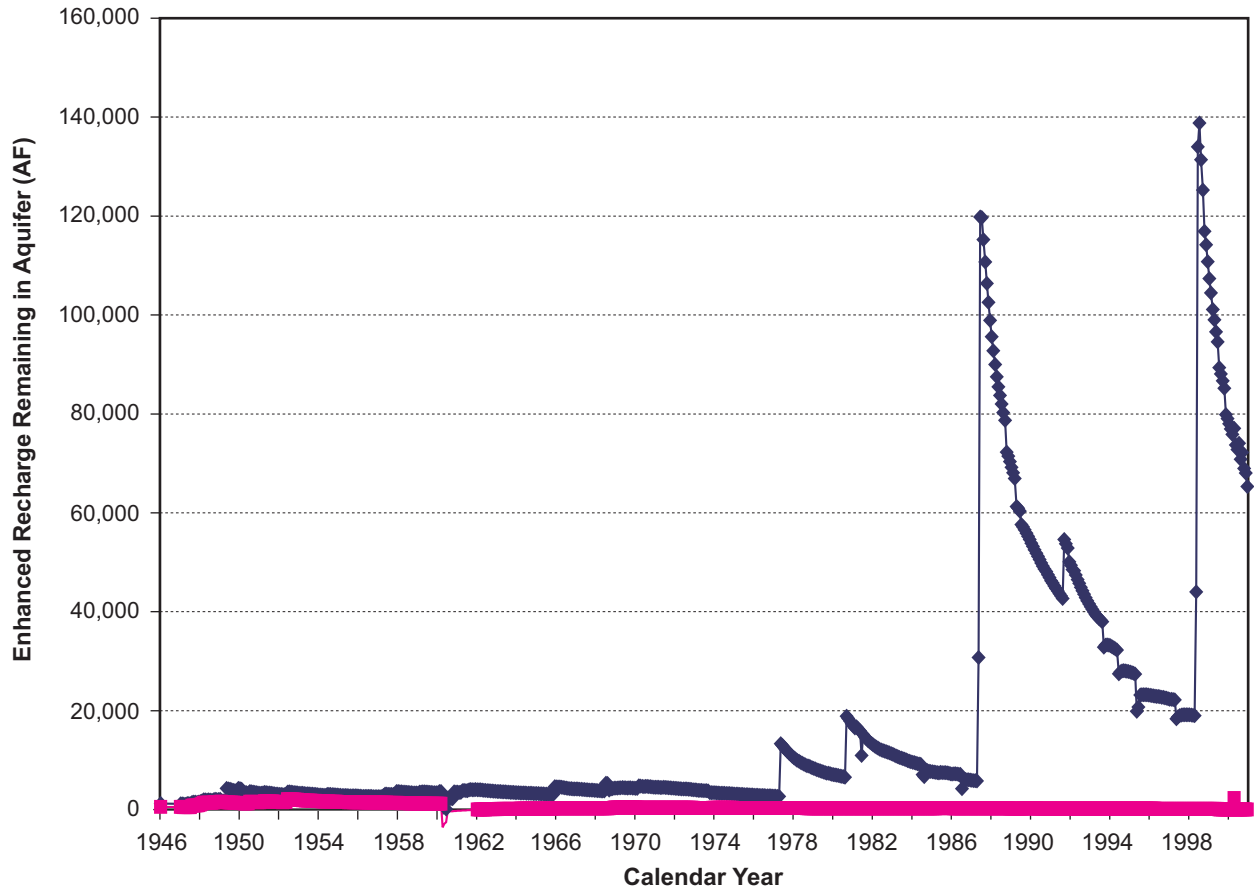

◆ Maximum (unappropriated and marketable)
■ Unappropriated

Note: Graphs 6-8 through 6-15 are conceptual analyses of source water impacts on aquifer storage at Type 2 locations and are conducted independent of actual site limitations to recharge.

December 2008	Figure 6-10 Recharge Remaining in the Aquifer over Time, Lower Sabinal
TODD ENGINEERS Alameda, California	

Enhanced Recharge in Aquifer Storage at Lower Hondo Type 2 Site

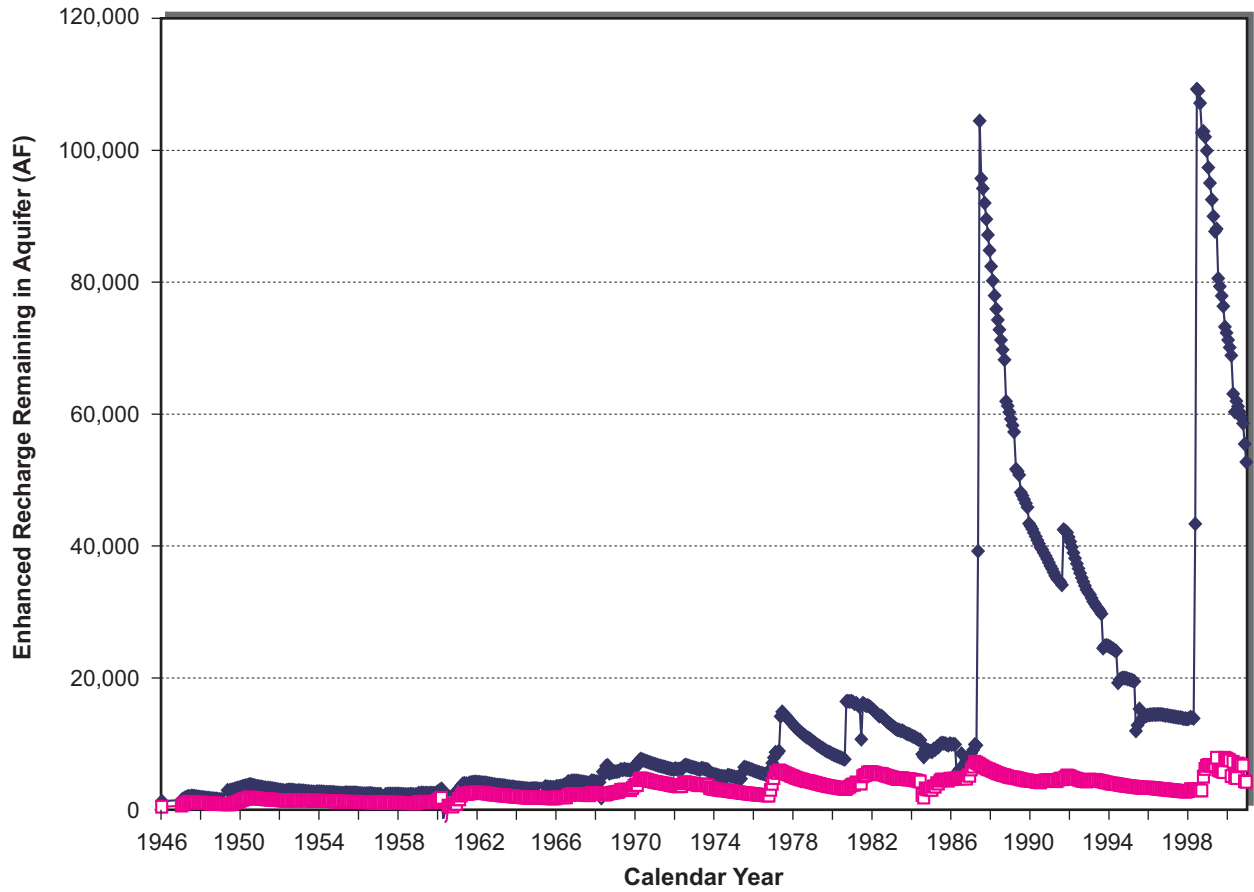

Maximum (unappropriated and marketable)
 Unappropriated

Note: Graphs 6-8 through 6-15 are conceptual analyses of source water impacts on aquifer storage at Type 2 locations and are conducted independent of actual site limitations to recharge.

December 2008	Figure 6-11 Recharge Remaining in the Aquifer over Time, Lower Hondo
TODD ENGINEERS Alameda, California	

Enhanced Recharge in Aquifer Storage at Lower Verde Type 2 Site

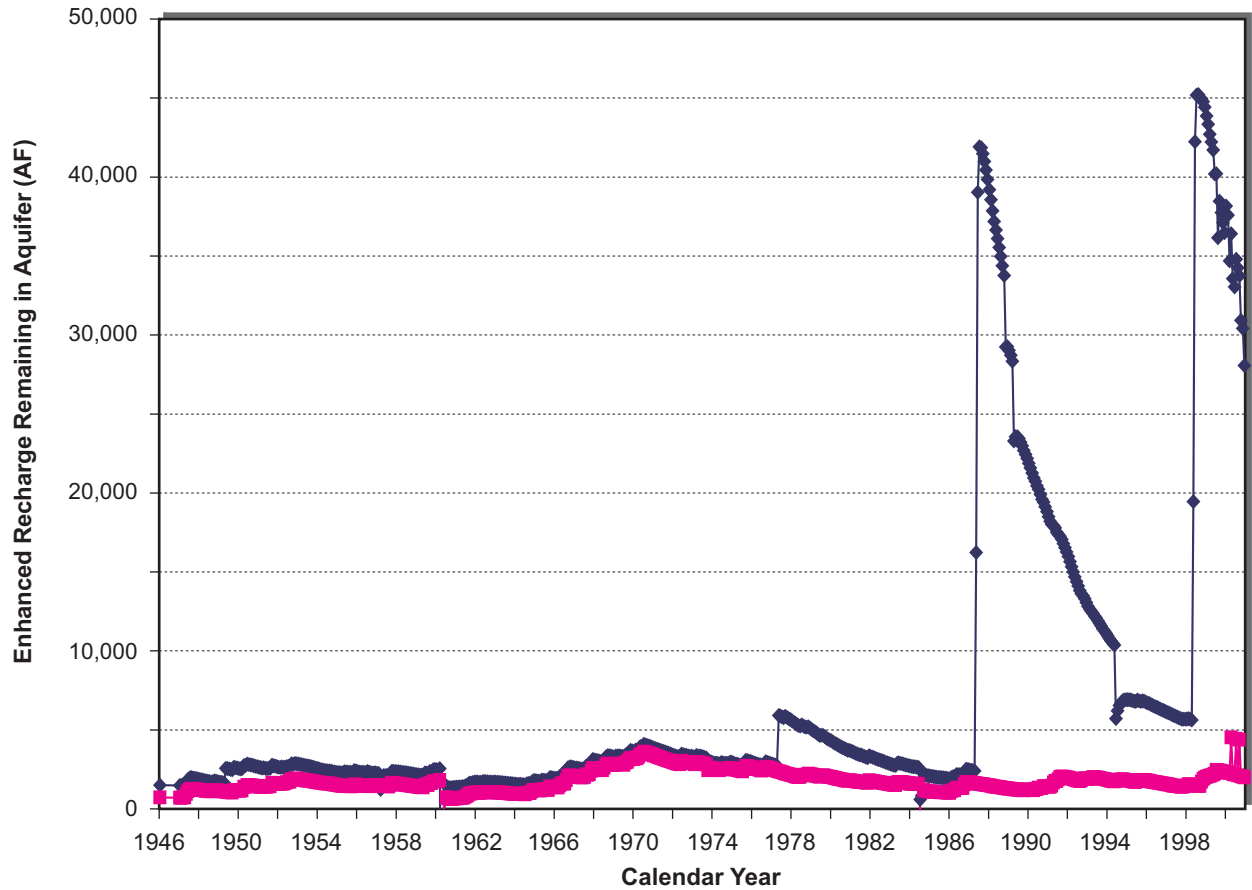

◆ Maximum (unappropriated and marketable)
■ Unappropriated

Note: Graphs 6-8 through 6-15 are conceptual analyses of source water impacts on aquifer storage at Type 2 locations and are conducted independent of actual site limitations to recharge.

December 2008	Figure 6-12 Recharge Remaining in the Aquifer over Time, Lower Verde
TODD ENGINEERS Alameda, California	

Enhanced Recharge in Aquifer Storage at San Geronimo Type 2 Site

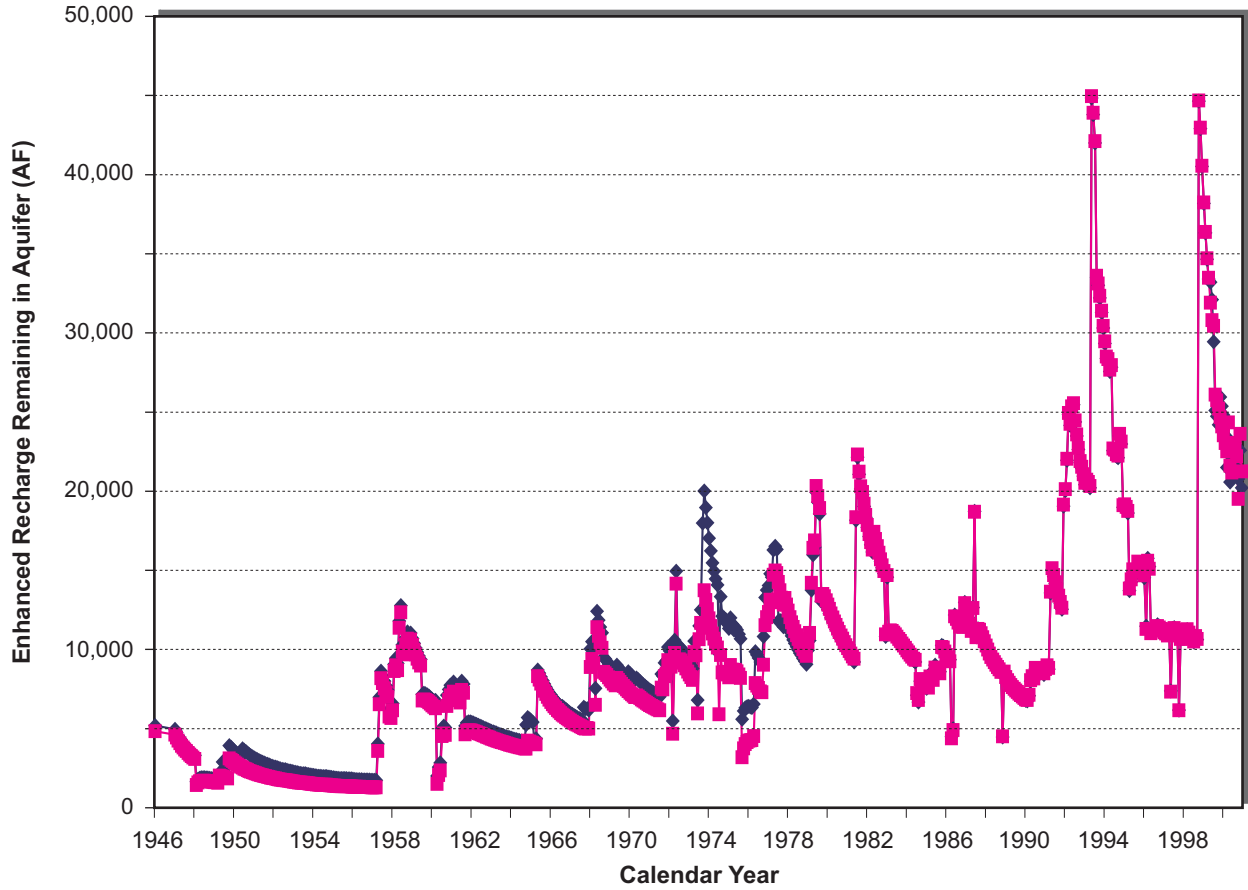

Maximum (unappropriated and marketable)
 Unappropriated

Note: Graphs 6-8 through 6-15 are conceptual analyses of source water impacts on aquifer storage at Type 2 locations and are conducted independent of actual site limitations to recharge.

December 2008	Figure 6-13 Recharge Remaining in the Aquifer over Time, San Geronimo
TODD ENGINEERS Alameda, California	

Enhanced Recharge in Aquifer Storage at Cibolo Dam Type 2 Site

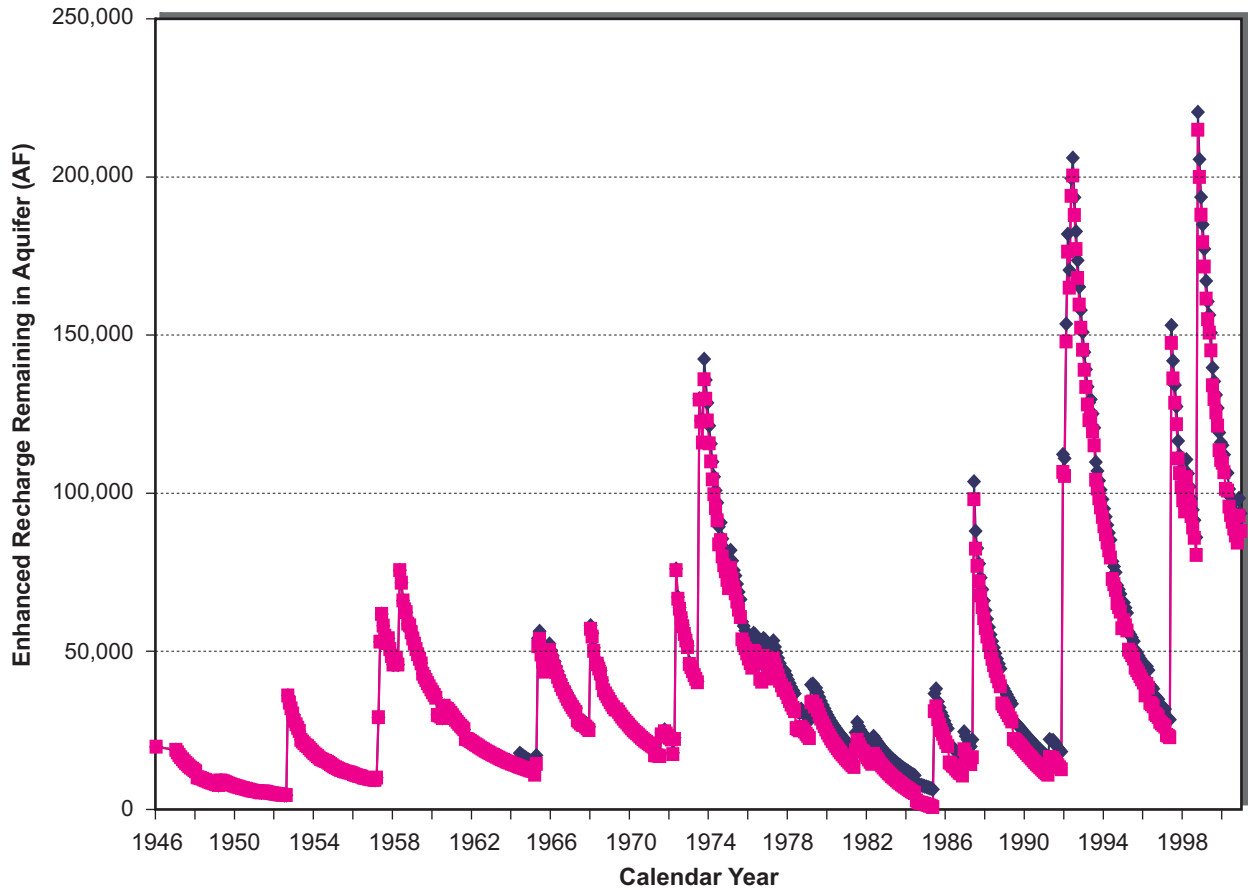

Maximum (unappropriated and marketable)
 Unappropriated

Note: Graphs 6-8 through 6-15 are conceptual analyses of source water impacts on aquifer storage at Type 2 locations and are conducted independent of actual site limitations to recharge.

December 2008	Figure 6-14 Recharge Remaining in the Aquifer over Time, Cibolo Dam
TODD ENGINEERS Alameda, California	

Enhanced Recharge in Aquifer Storage at Lower Blanco Type 2 Site

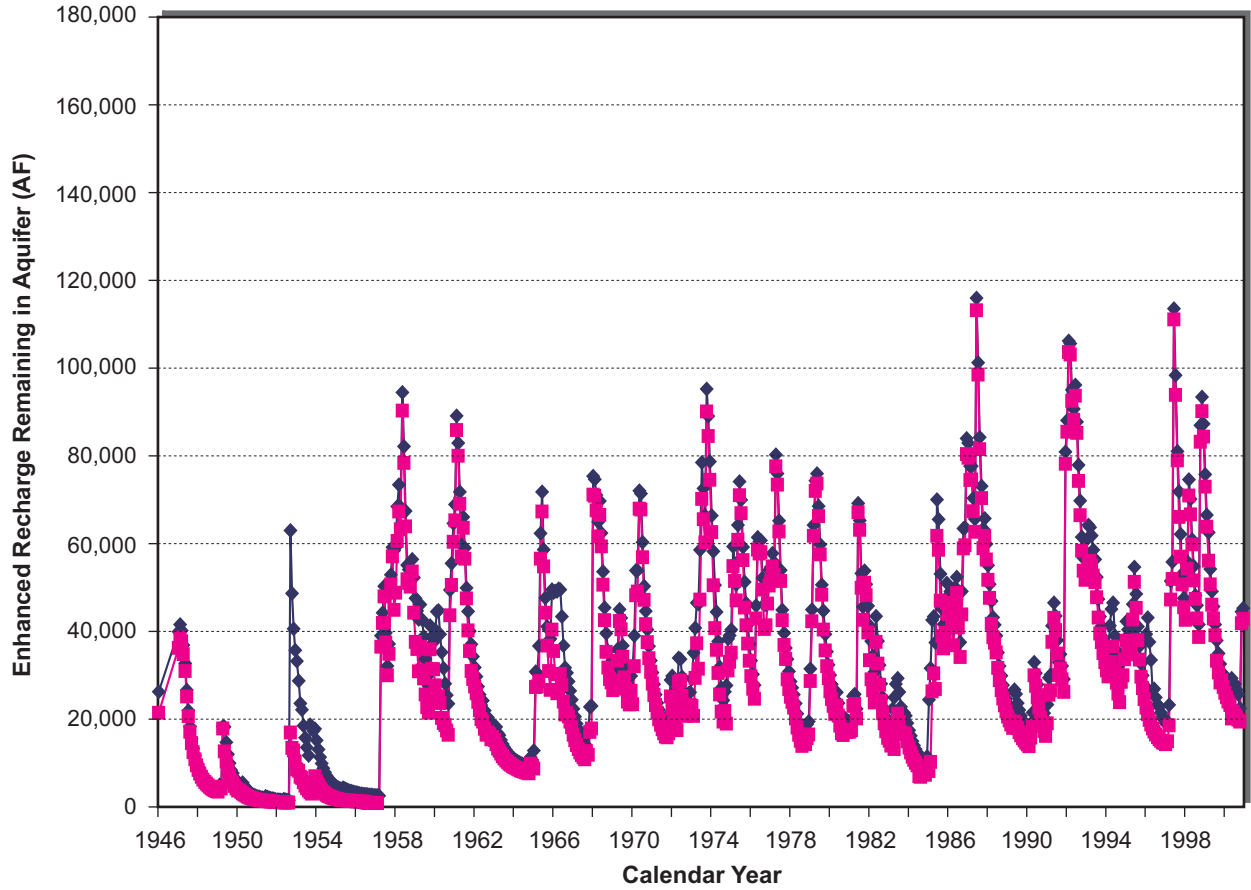

◆ Maximum (unappropriated and marketable) ■ Unappropriated

Note: Graphs 6-8 through 6-15 are conceptual analyses of source water impacts on aquifer storage at Type 2 locations and are conducted independent of actual site limitations to recharge.

December 2008	Figure 6-15 Recharge Remaining in the Aquifer over Time, Lower Blanco
TODD ENGINEERS Alameda, California	

Enhanced Recharge Program at All Type 2 Sites

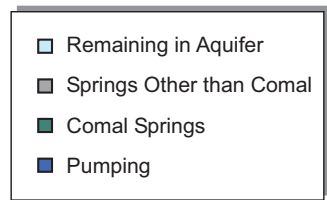
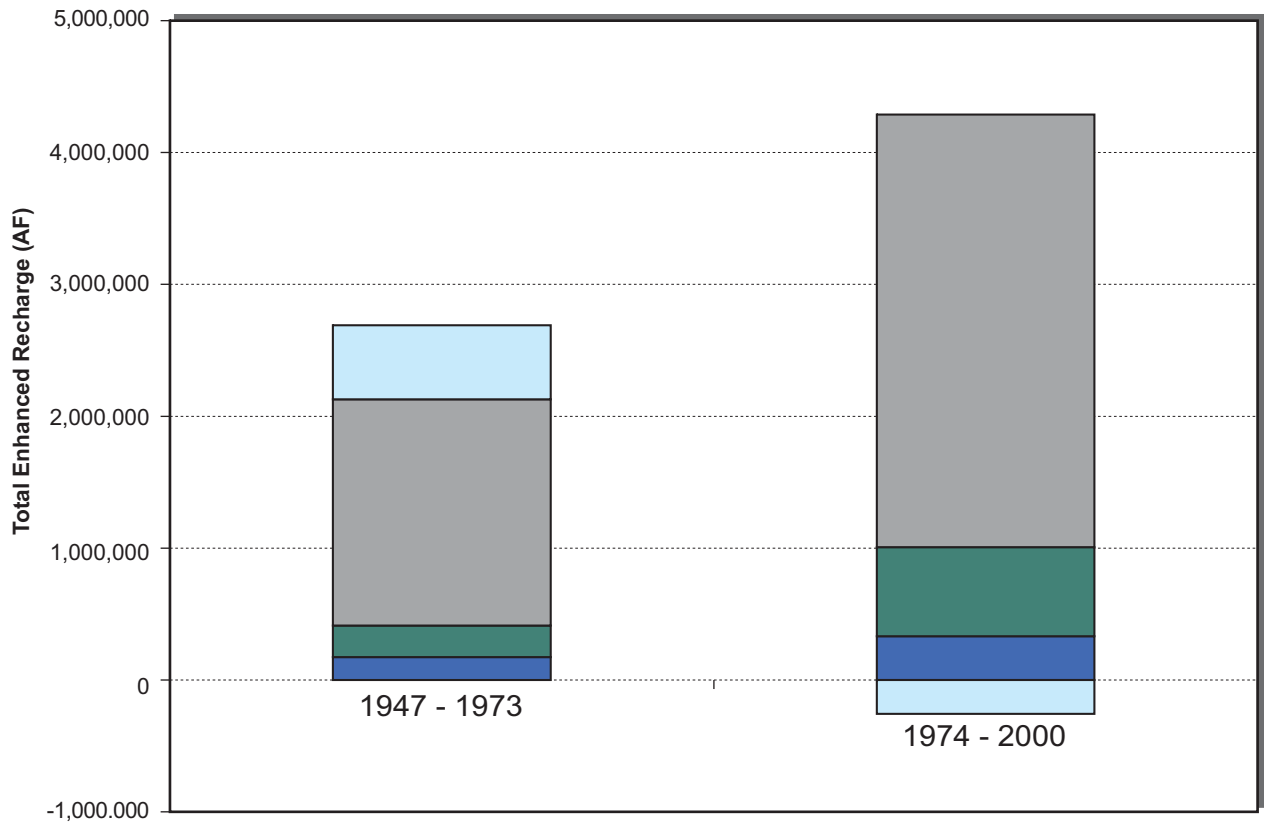

Note: Source water for recharge is unappropriated water as estimated with the WAM.

October 2008	Figure 6-16 Total Yield Enhanced Recharge at All Type 2 Sites
TODD ENGINEERS Alameda, California	

Enhanced Recharge Program at Type 2 Sites Except Lower Blanco

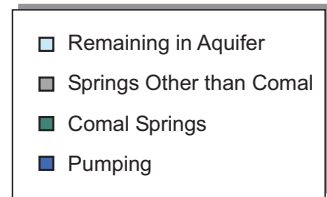
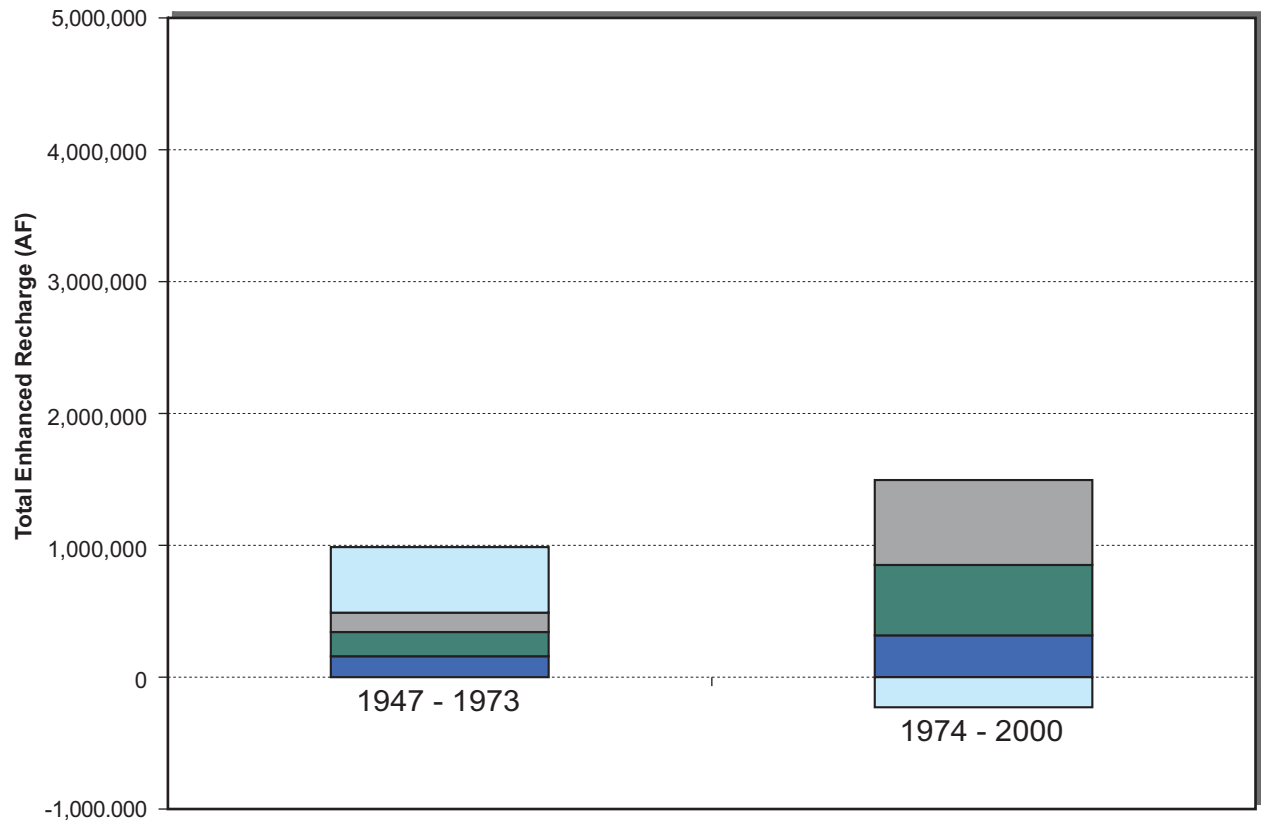

Note: Source water for recharge is unappropriated water as estimated with the WAM.

October 2008
TODD ENGINEERS Alameda, California

Figure 6-17
Total Yield Enhanced Recharge Type 2 Sites (Excluding Lower Blanco)

Enhanced Recharge Program at Type 2 Sites Using HDR Estimates

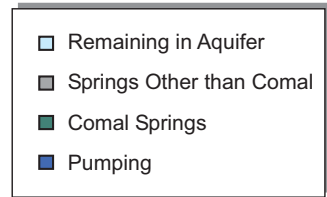
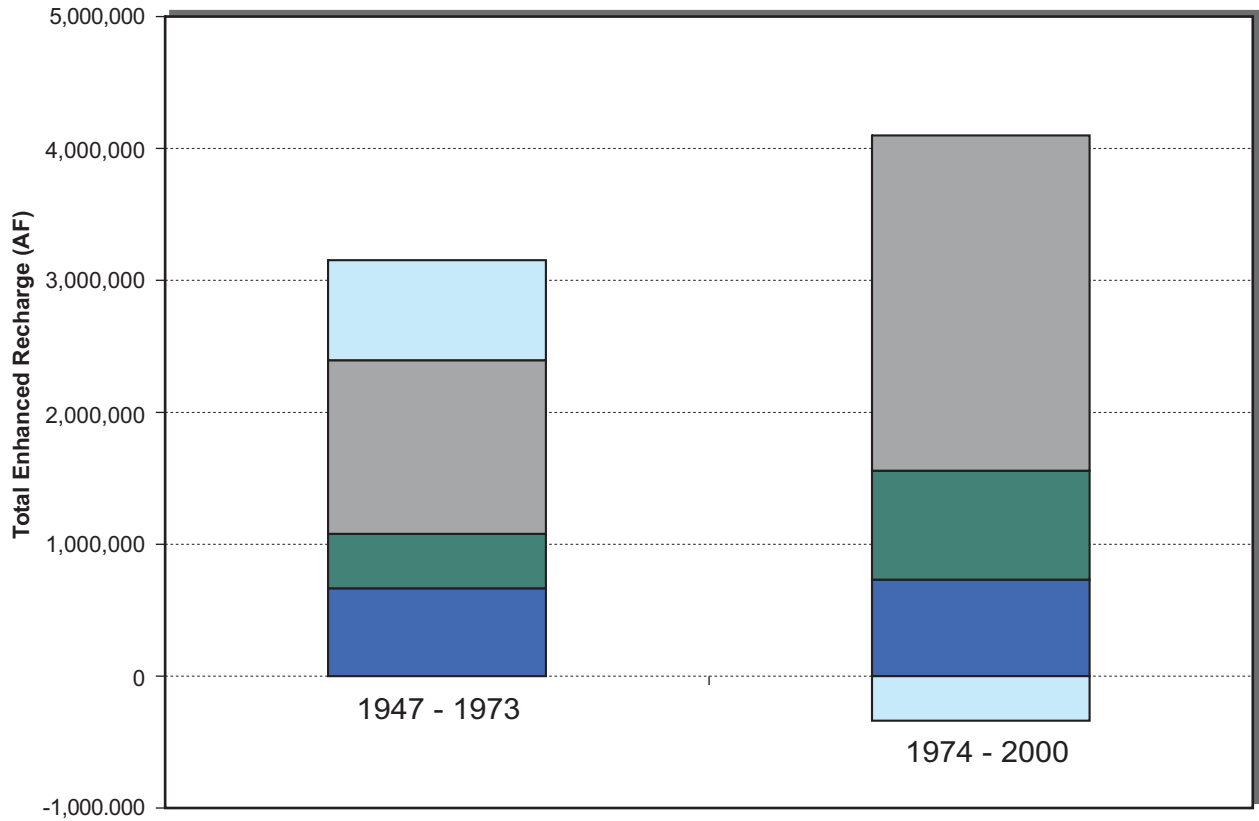

Note: Source water for recharge was provided by HDR Engineering as used in previous analysis on the Type 2 recharge sites (HDR, 2008).

October 2008
TODD ENGINEERS
Alameda, California

Figure 6-18
Total Yield of Type 2
Enhanced Recharge
With HDR
Source Water Estimates

Enhanced Recharge at Type 2 Sites (Except Lower Blanco) Using HDR Estimates

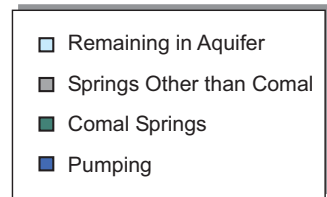
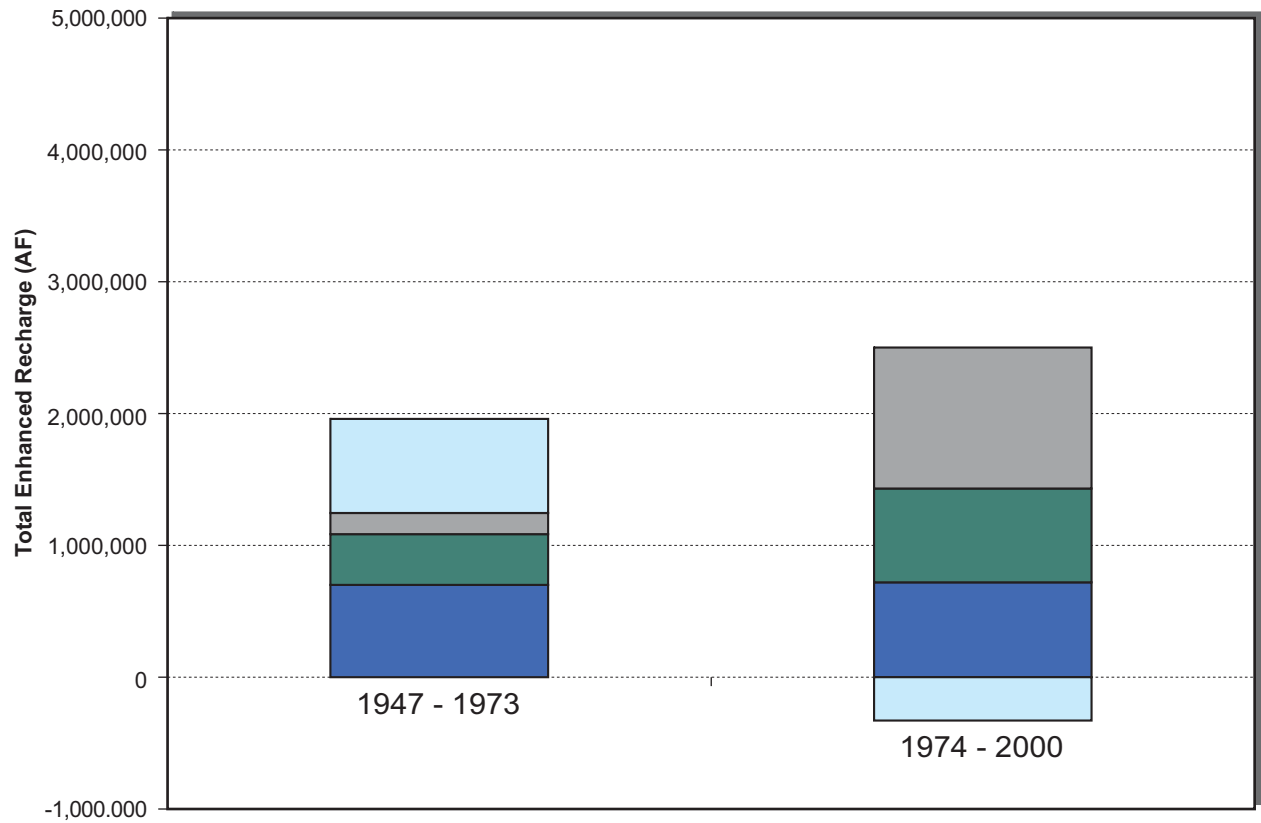

Note: Source water for recharge was provided by HDR Engineering as used in previous analysis on the Type 2 recharge sites (HDR, 2008).

October 2008
TODD ENGINEERS
Alameda, California

Figure 6-19
Total Yield of Type 2 (excluding Lower Blanco) Enhanced Recharge With HDR Source Water Estimates

Evaluation of Recharge of Excess Springflow at Comal Springs

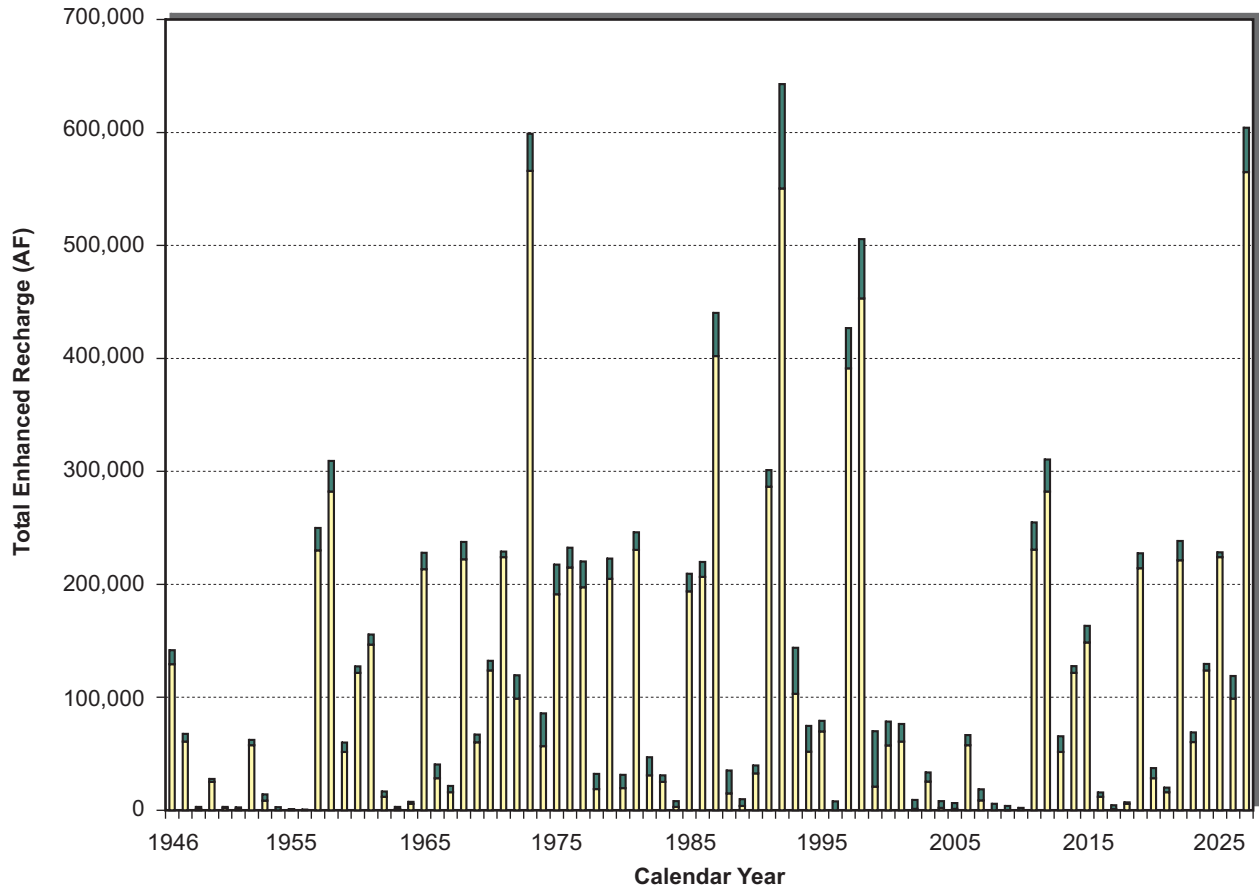

Excess Springflow at Comal Springs
 Source Water at Type 2 Recharge Locations

Note: Excess springflow defined as the increase of flow at Comal Springs that results from enhanced recharge.

October 2008	Figure 6-20 Total Source Water for Enhanced Recharge at Type 2 Sites with Excess Springflow
TODD ENGINEERS Alameda, California	

Enhanced Recharge with Springflow Recirculation

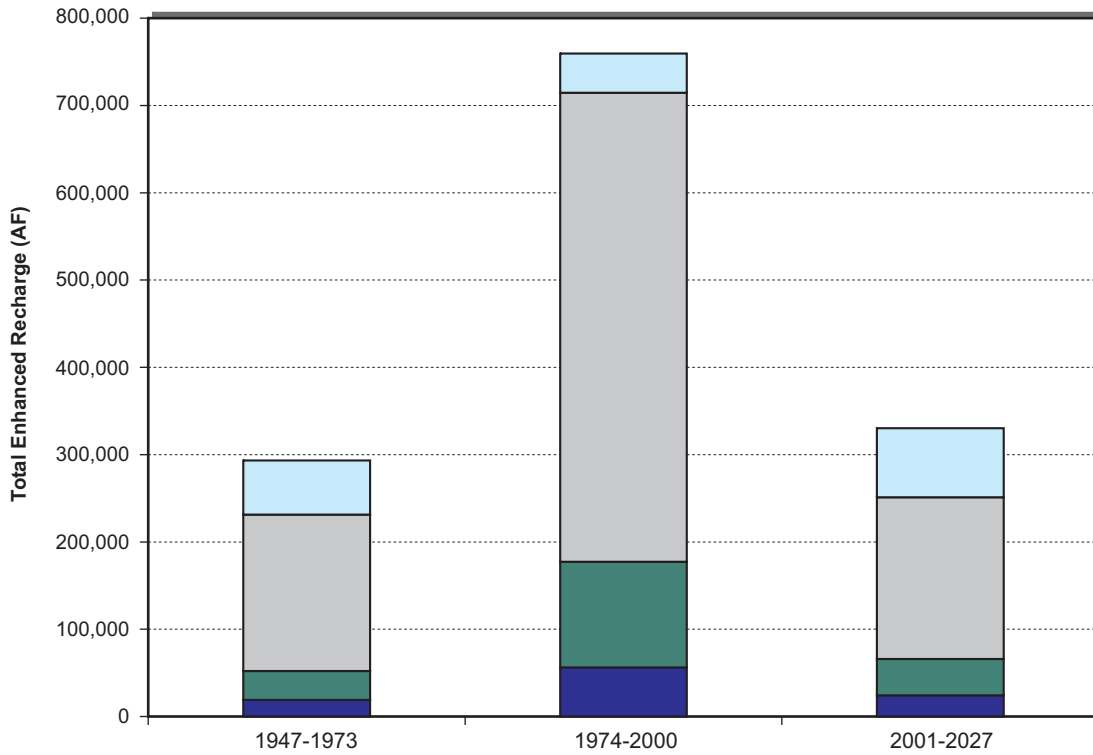

Note: Excess springflow recirculated at Cibolo recharge site.

Enhanced Recharge without Springflow Recirculation

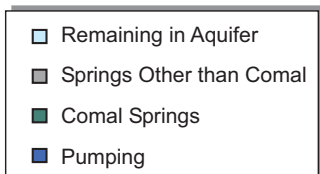
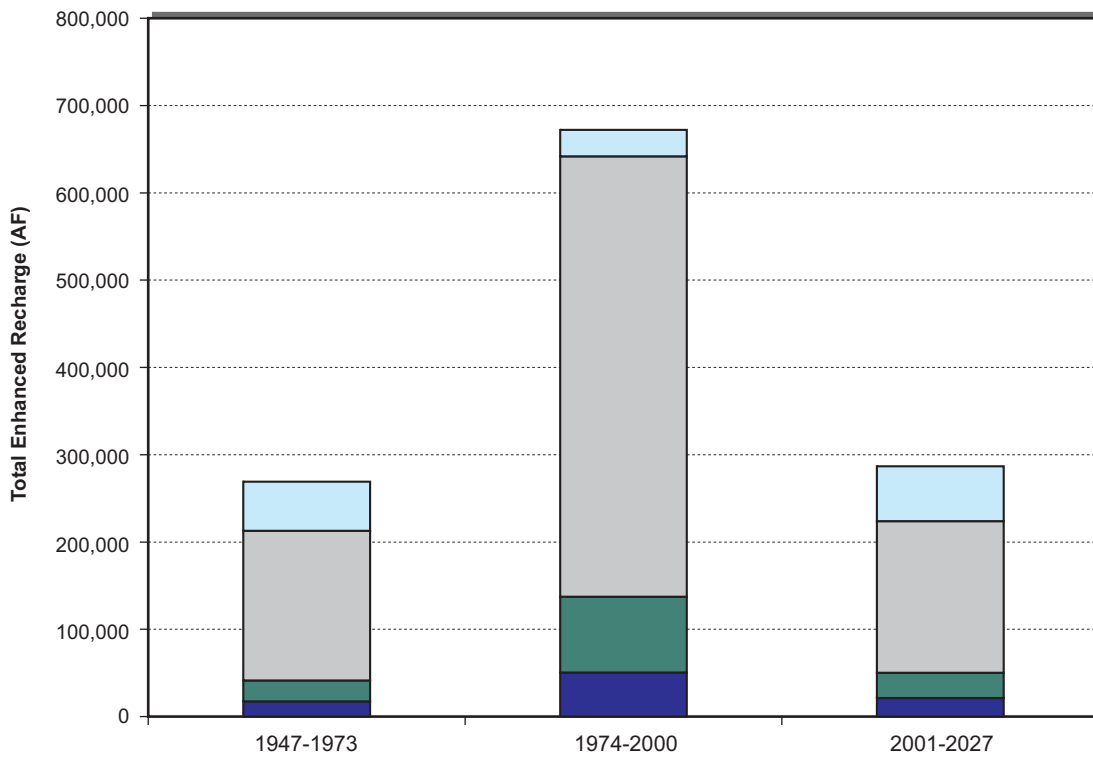

October 2008
TODD ENGINEERS
Alameda, California

Figure 6-21
Yield of
Excess Springflow
Recirculation

Annual Amounts of Enhanced Recharge Scenarios 1, 2, and 5

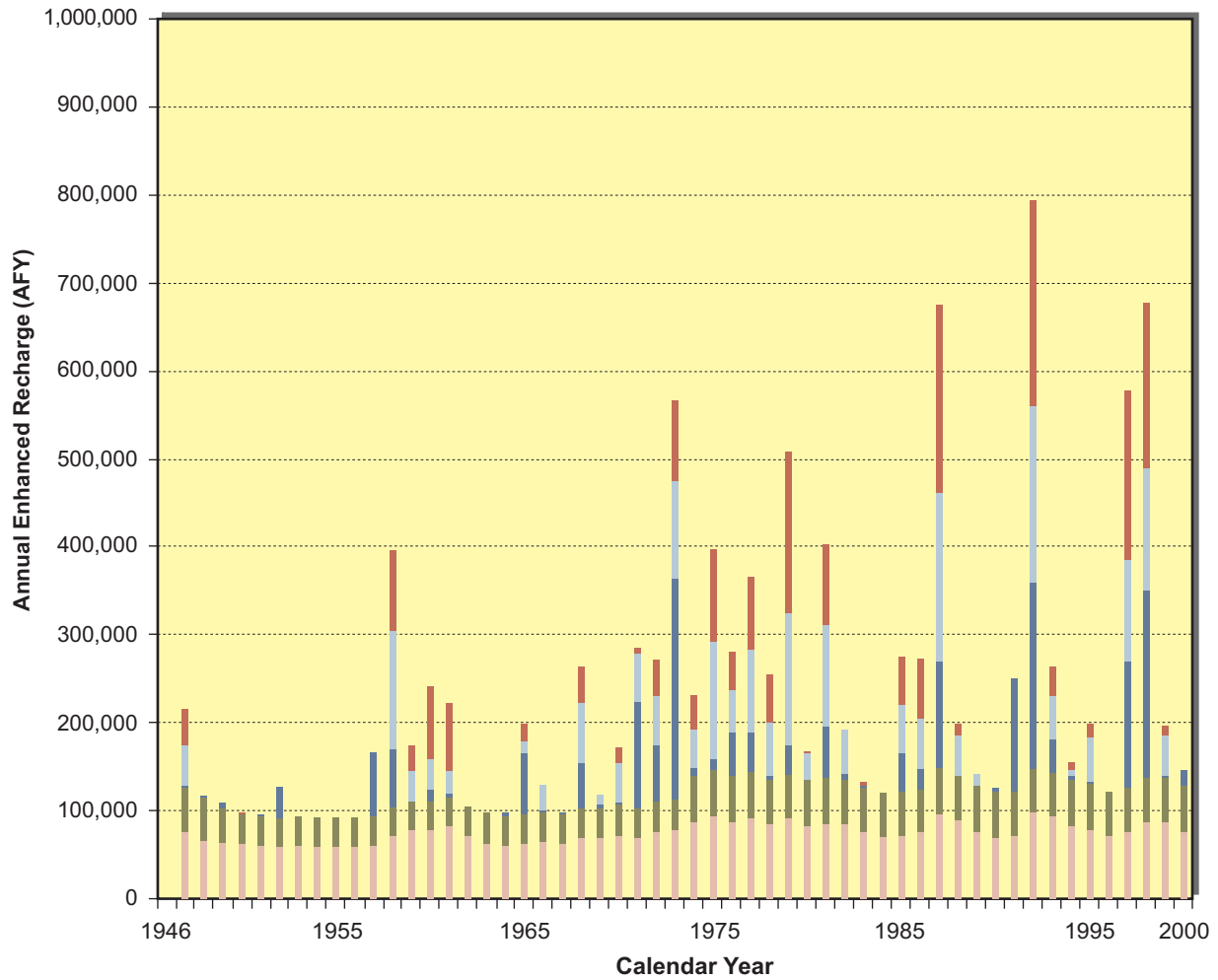

- Diversion of Unappropriated Water at Lake Dunlap
- Diversion of Unappropriated Water at Comfort/Medina River
- Combined Unappropriated Water at Type 2 recharge sites (except Lower Blanco)
- Unused withdrawal permits from Uvalde wellfield
- Unused withdrawal permits from Medina wellfield

December 2008
TODD ENGINEERS
Alameda, California

Figure 7-1
Enhanced Recharge
Scenarios 1, 2, and 5

Recovery Factors

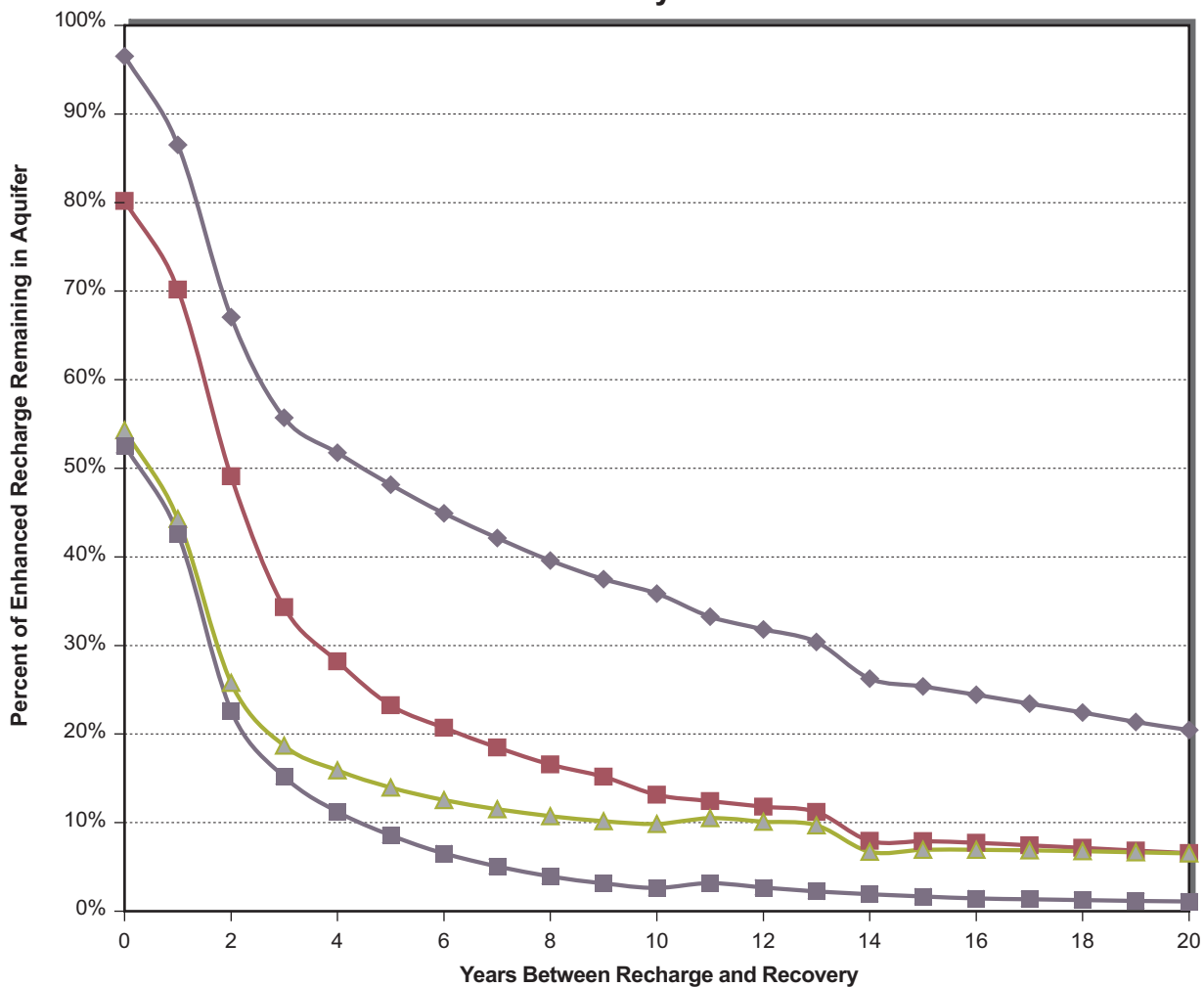

- ◆ Western Recharge Sites (Indian Creek, Dry Frio, Lower Frio)
- Central Recharge Sites (Lower Sabinal, Seco Creek, Lower Hondo, Lower Verde)
- ▲ San Geronimo Recharge Site
- Cibolo Recharge Site

Note: These factors relate the total amount of recharge to the portion that could potentially be recovered by pumping. Factors were developed by Todd Engineers based on aquifer retention times analyzed for each of the recharge sites under baseline conditions.

Total Yield of Scenario 1a (Without Enhanced Pumping)

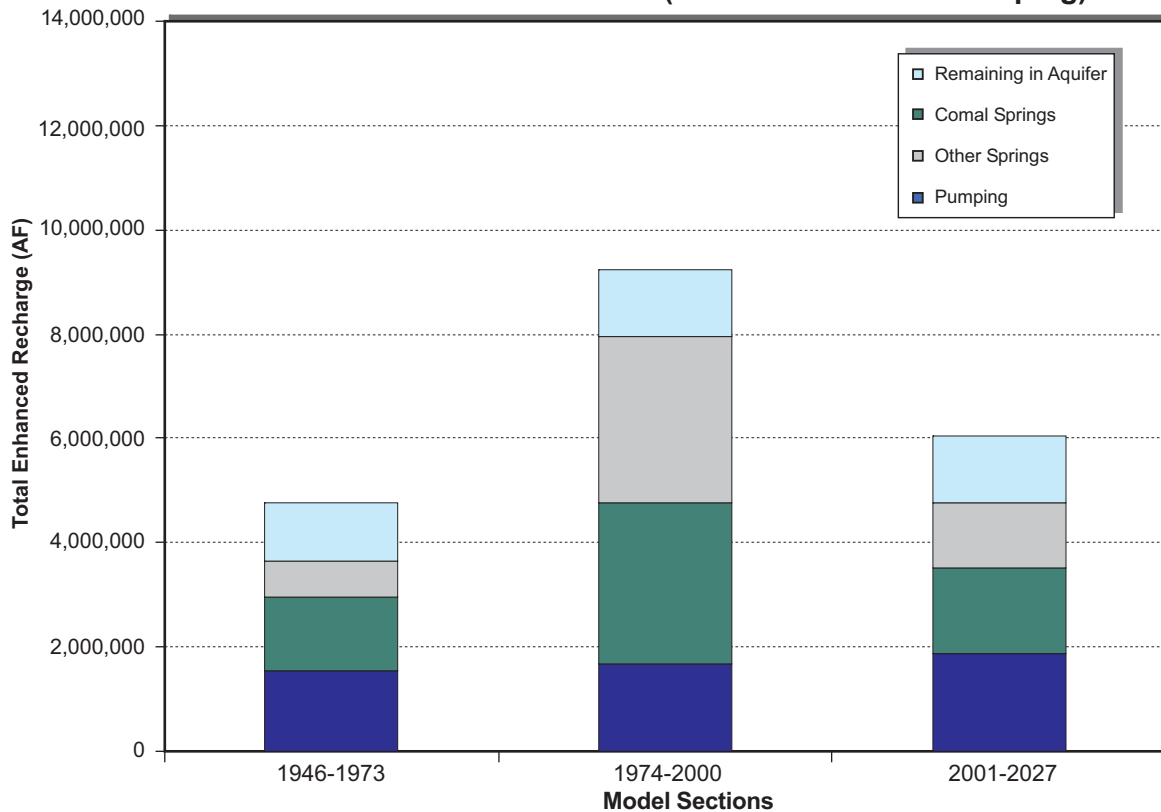

Comal Springs - Scenario 1a (Without Enhanced Pumping)

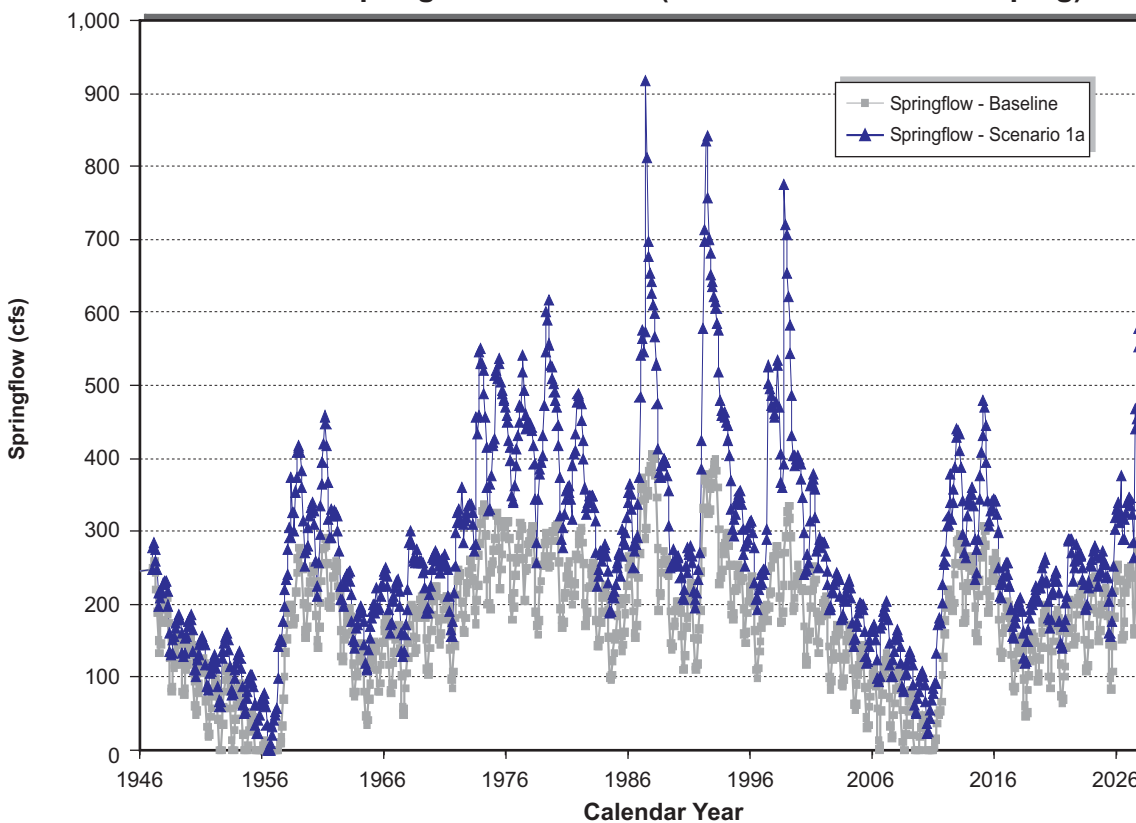

December 2008

TODD ENGINEERS
Alameda, California

Figure 7-3
Results of
Scenario 1a Without
Enhanced Pumping

Total Yield of Scenario 1b (With Enhanced Pumping)

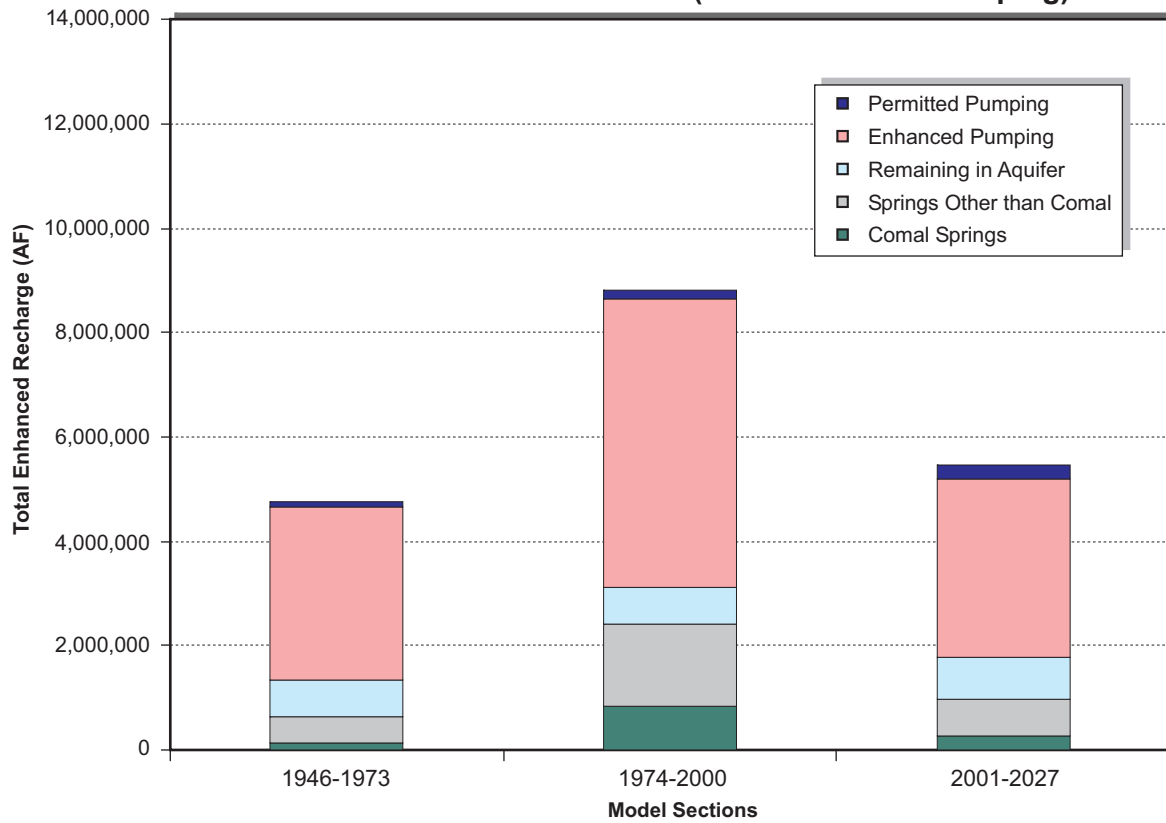

Comal Springs - Scenario 1b (With Enhanced Pumping)

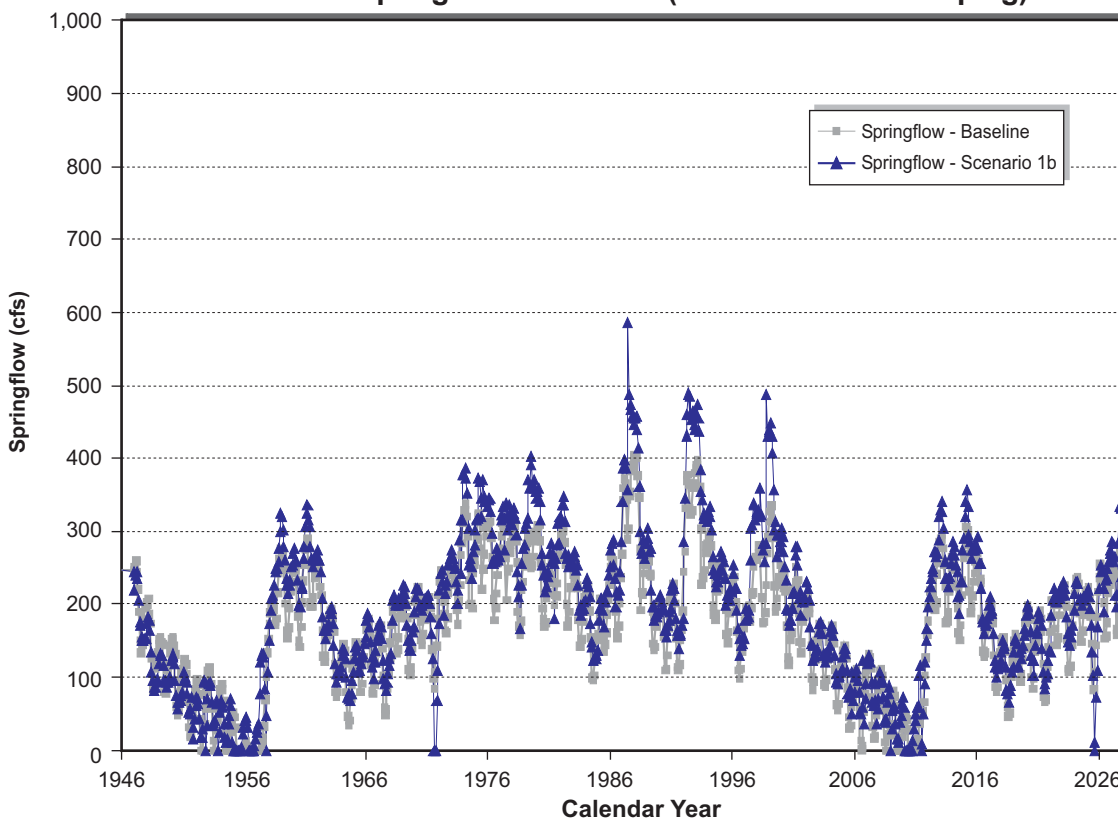

December 2008

TODD ENGINEERS
Alameda, California

Figure 7-4
Results of
Scenario 1b With
Enhanced Pumping

Total Yield of Scenario 2

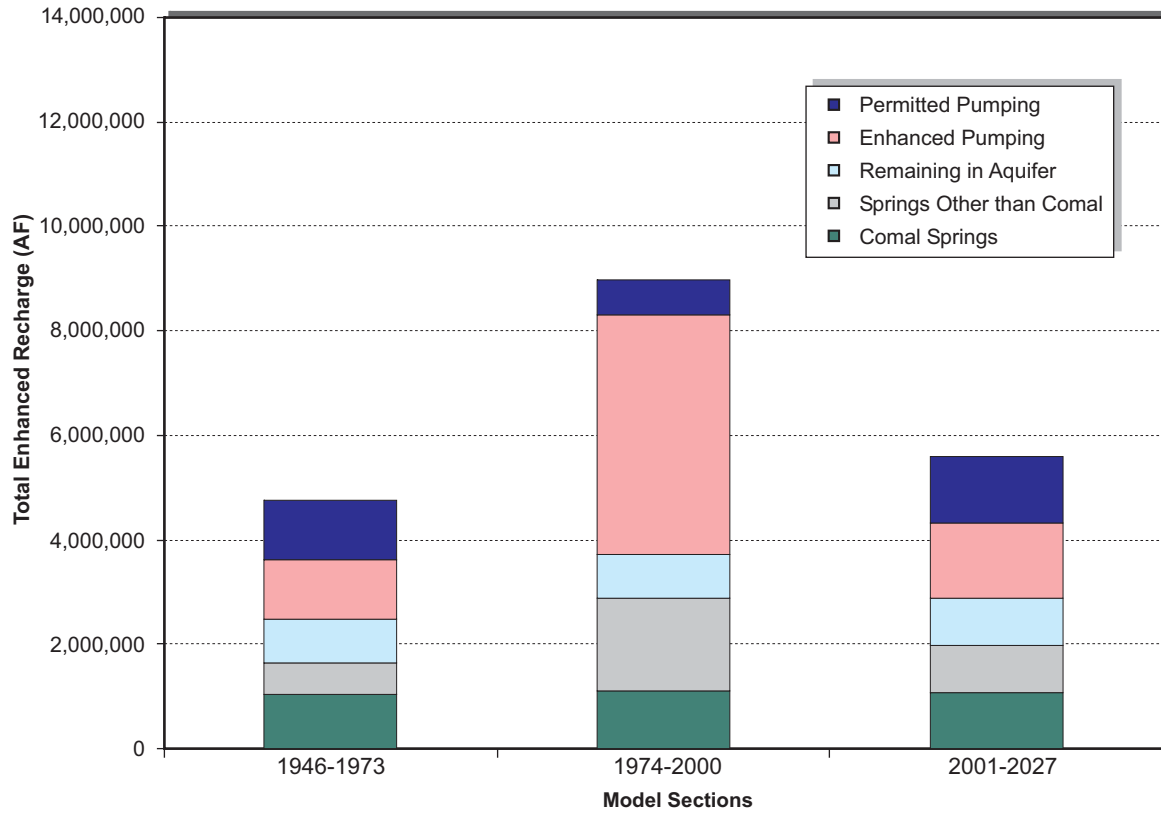

Comal Springs - Scenario 2

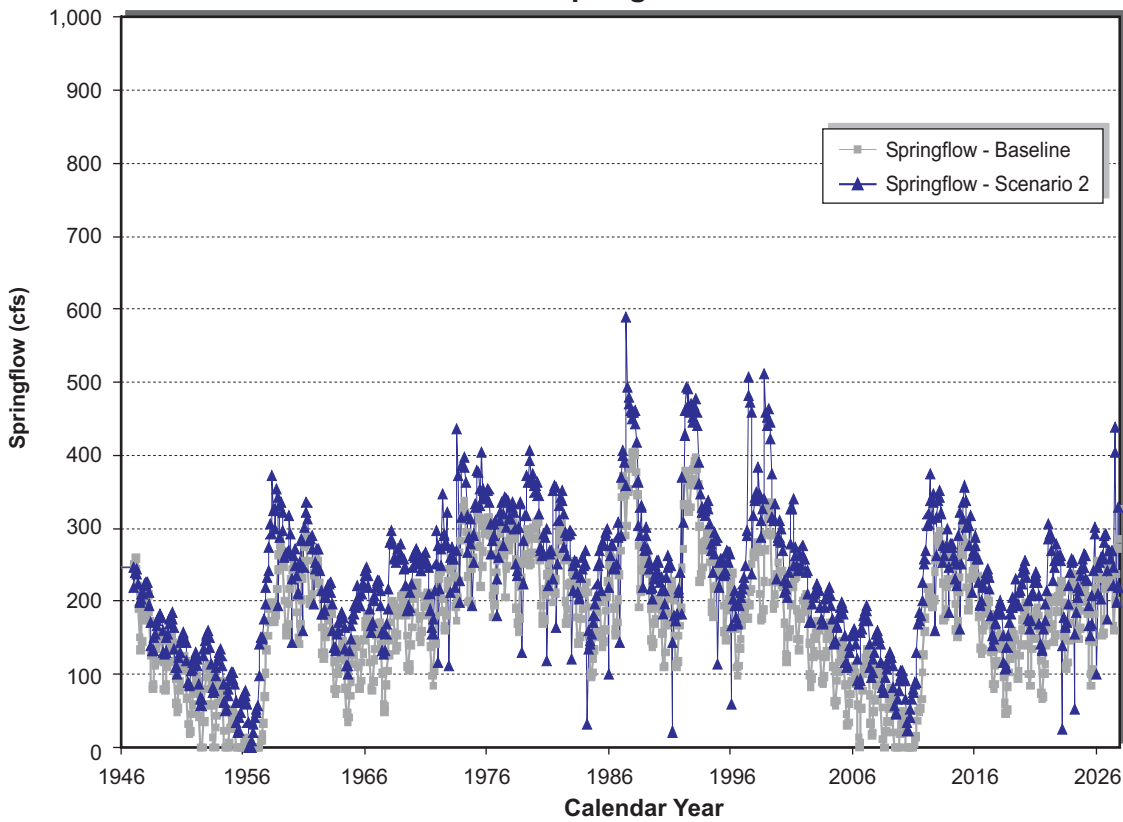

December 2008

TODD ENGINEERS
Alameda, California

Figure 7-5
Results of
Scenario 2

Annual Amounts of Enhanced Recharge Scenarios 3 and 4

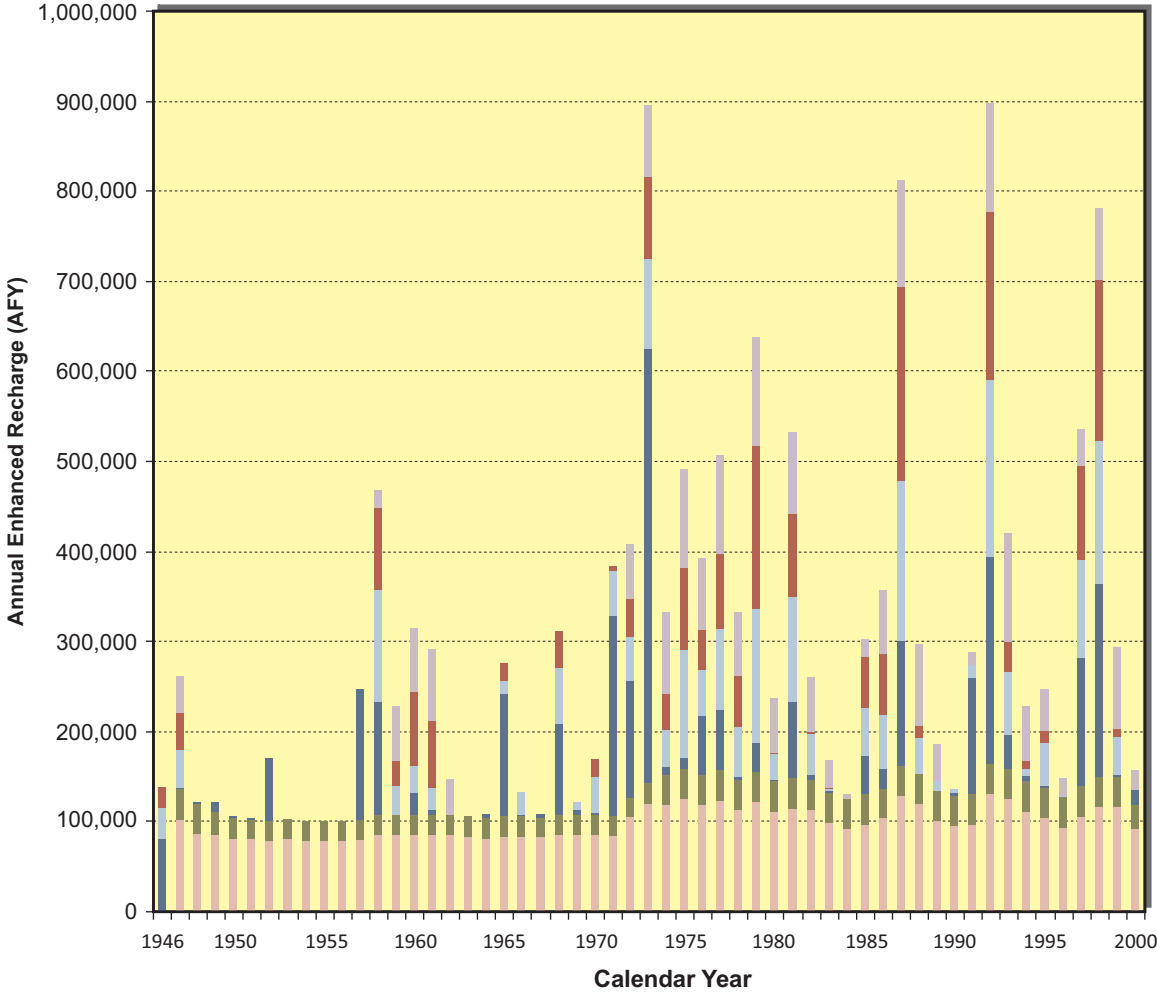

- Additional water pumped for recirculation
- Diversion of Unappropriated Water at Lake Dunlap
- Diversion of Unappropriated Water at Comfort and Medina River
- Combined Unappropriated Water at Type 2 recharge sites (except Lower Blanco)
- Unused withdrawal permits from Uvalde wellfield
- Unused withdrawal permits from Medina wellfield

December 2008
TODD ENGINEERS
Alameda, California

Figure 7-6
Enhanced Recharge
for
Scenarios 3 and 4

Pumping for Recovery and/or Recirculation

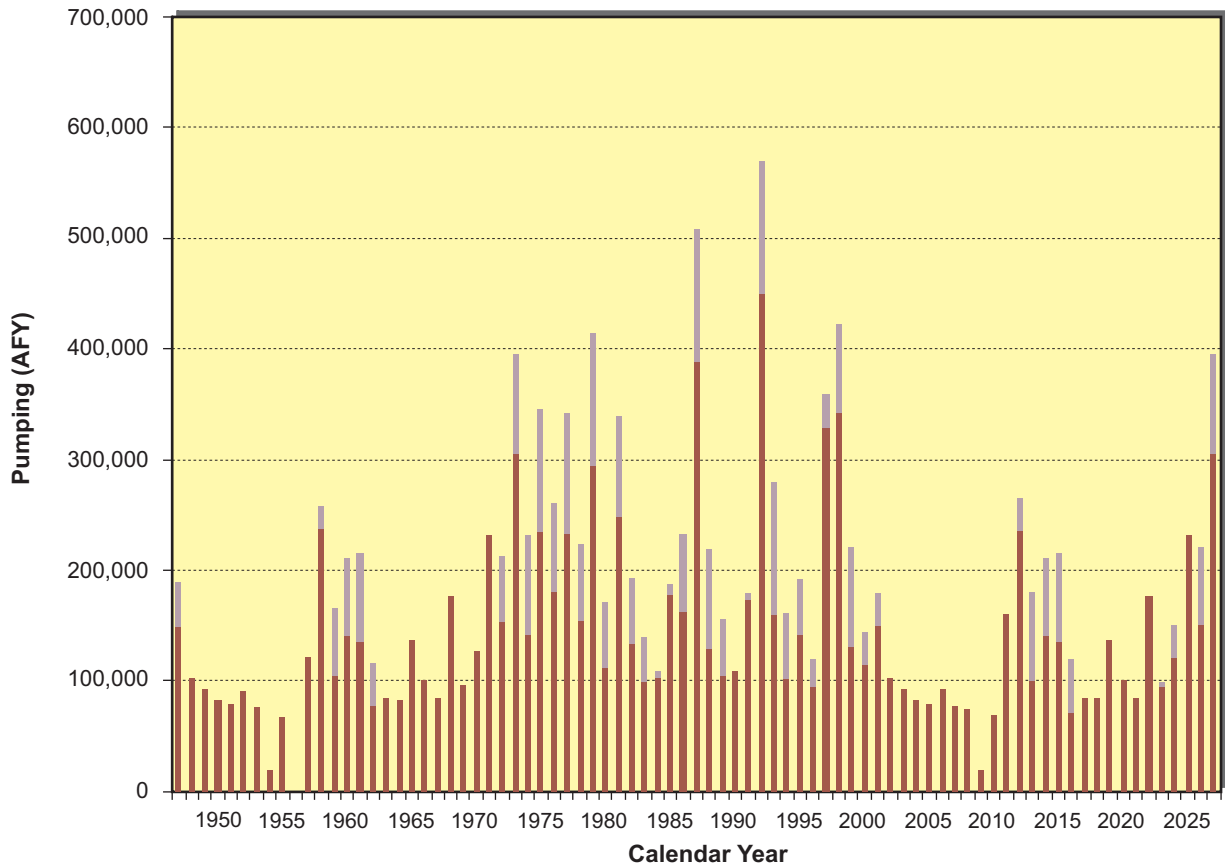

Recirculation Pumping
 (Pumping for Recharge)

Enhanced Pumping
 (Pumping for Use)

December 2008

TODD ENGINEERS
Alameda, California

Figure 7-7
Scenario 3
Enhanced Pumping
and Recirculation
Pumping

Total Yield of Scenario 3

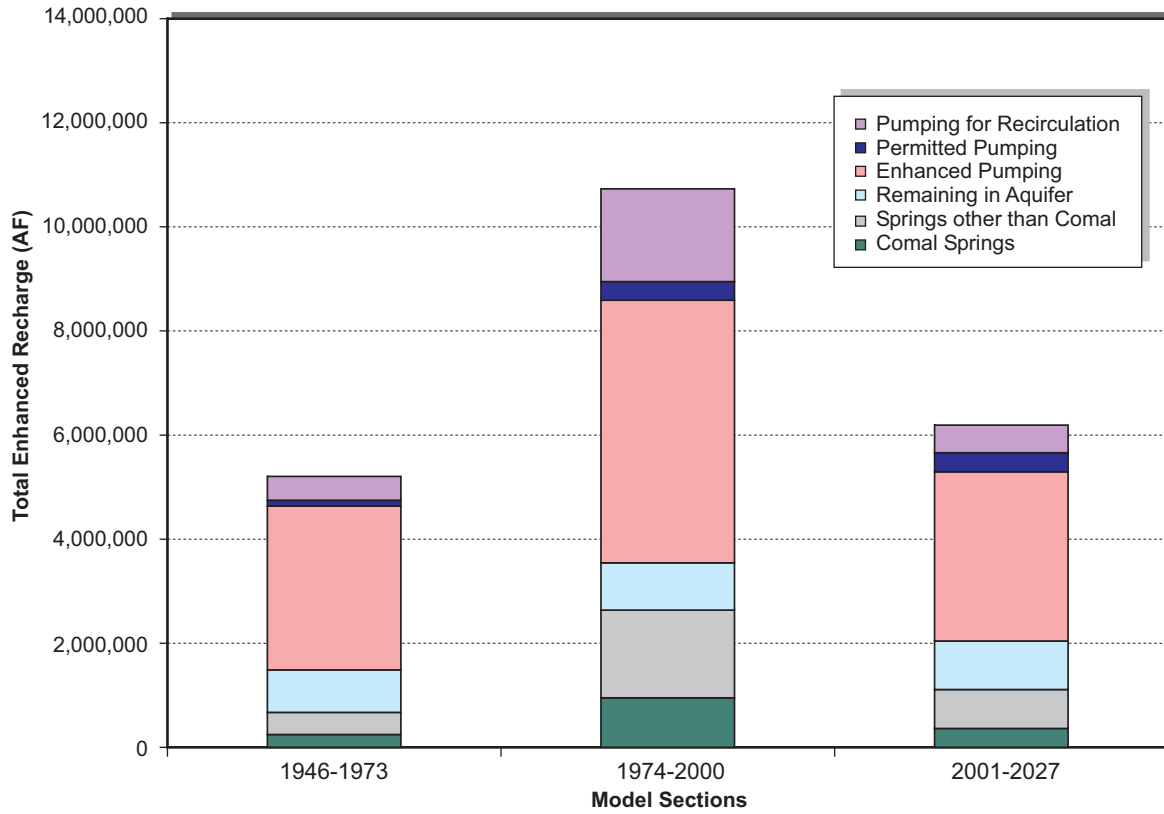

Comal Springs - Scenario 3

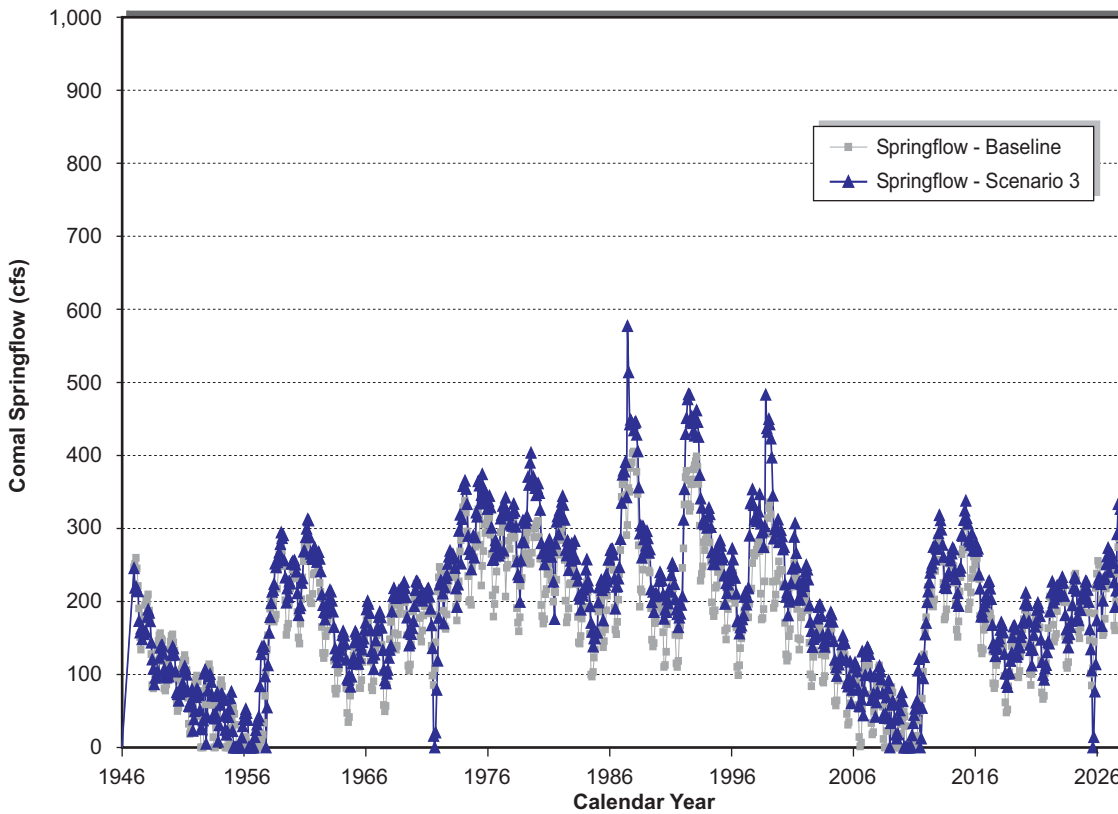

December 2008

TODD ENGINEERS
Alameda, California

Figure 7-8
Results of
Scenario 3 With
Enhanced/Recirculation
Pumping

Pumping for Recovery and Recirculation

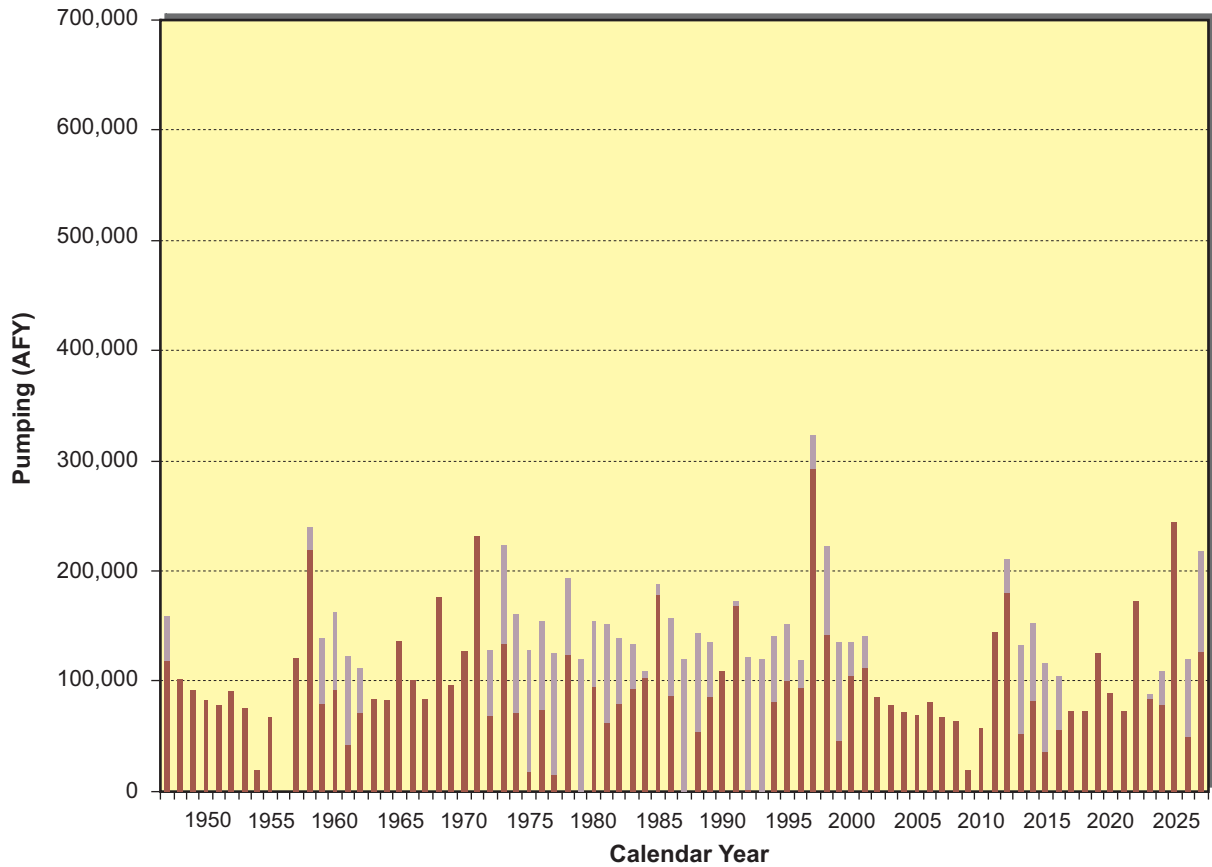

Recirculation Pumping
 (Pumping for Recharge)

Enhanced Pumping
 (Pumping for Use)

December 2008

TODD ENGINEERS
Alameda, California

Figure 7-9
Scenario 4
Enhanced Pumping
and Recirculation

Total Yield of Scenario 4

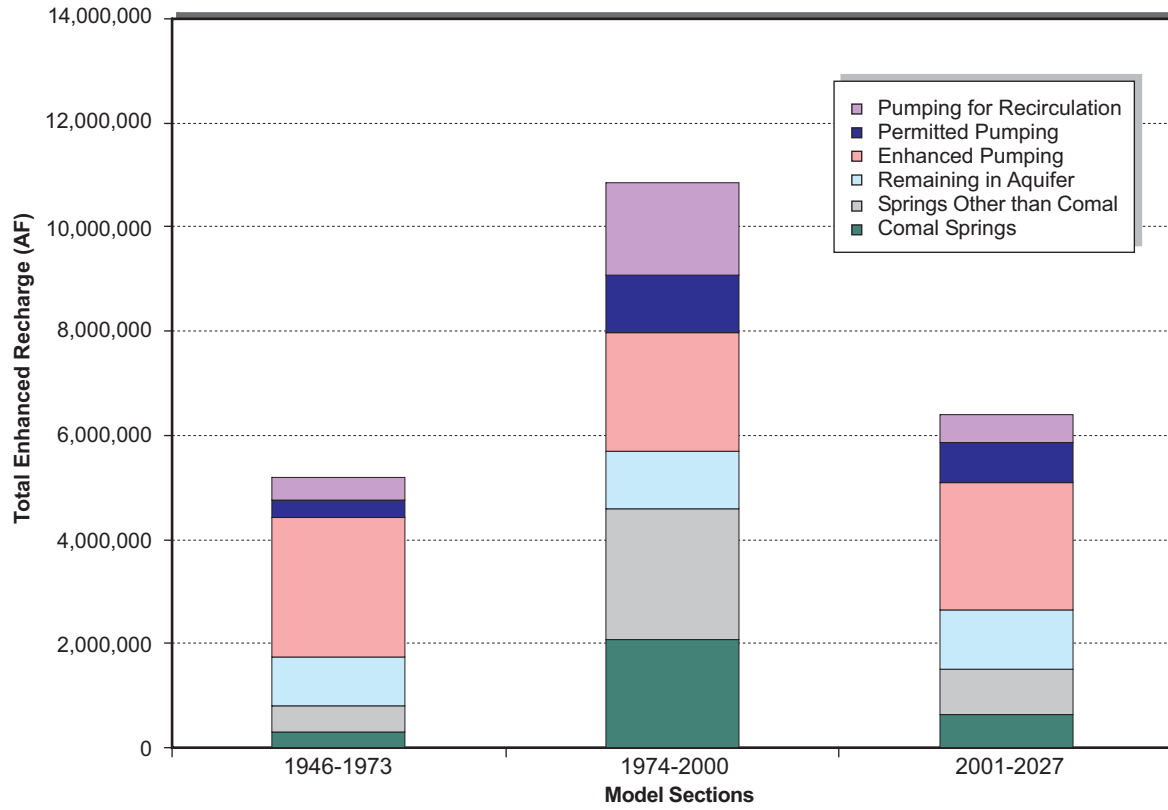

Comal Springs - Scenario 4

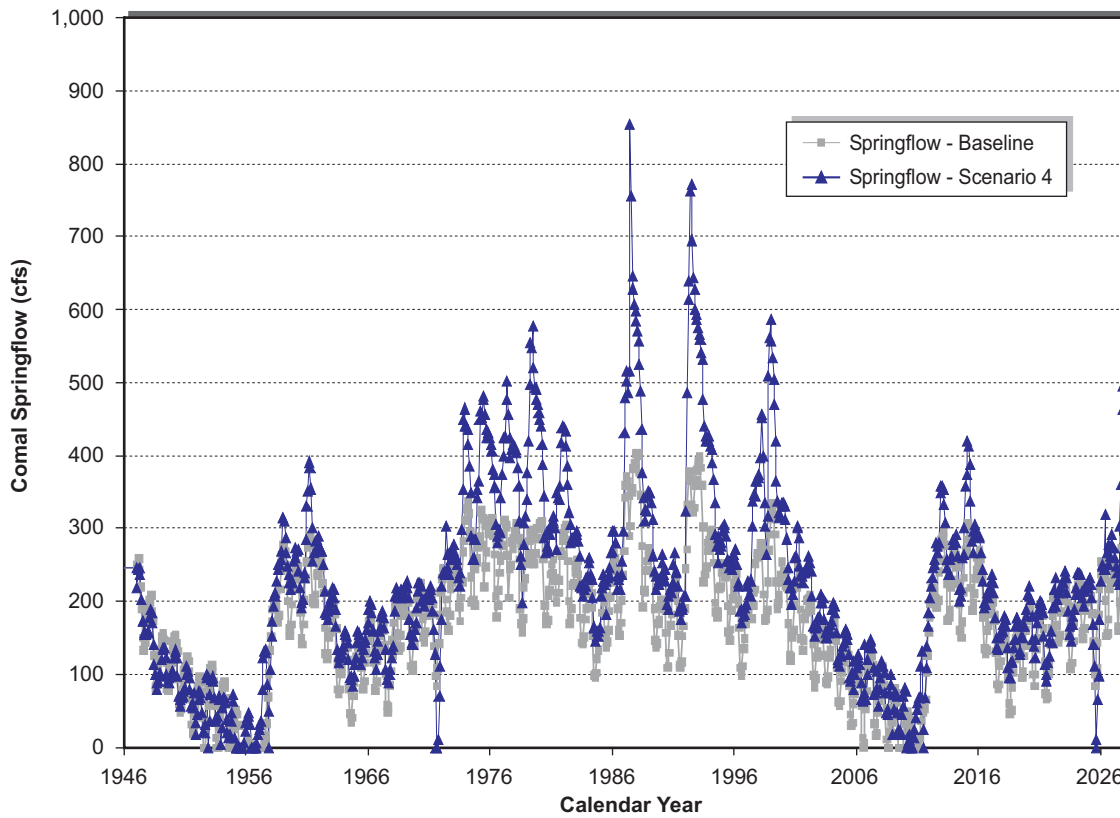

December 2008

TODD ENGINEERS
Alameda, California

Figure 7-10
Results of
Scenario 4

Total Yield of Scenario 5

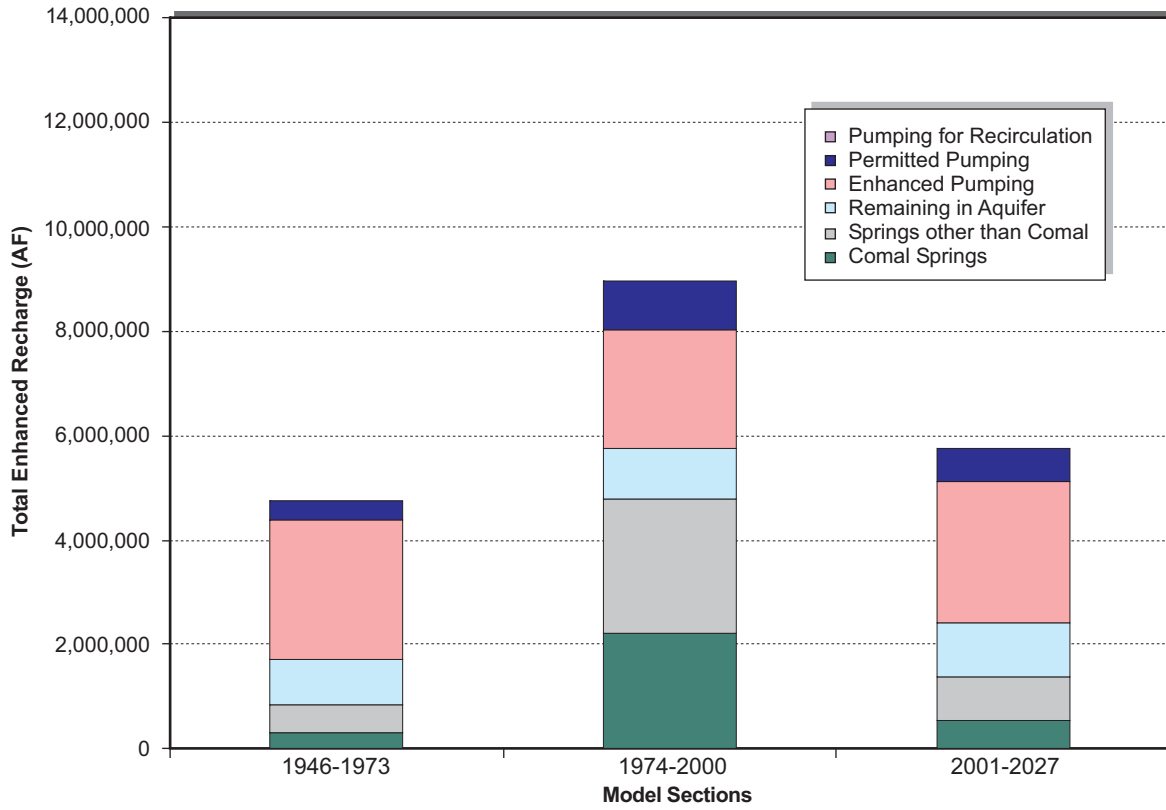

Comal Springs - Scenario 5

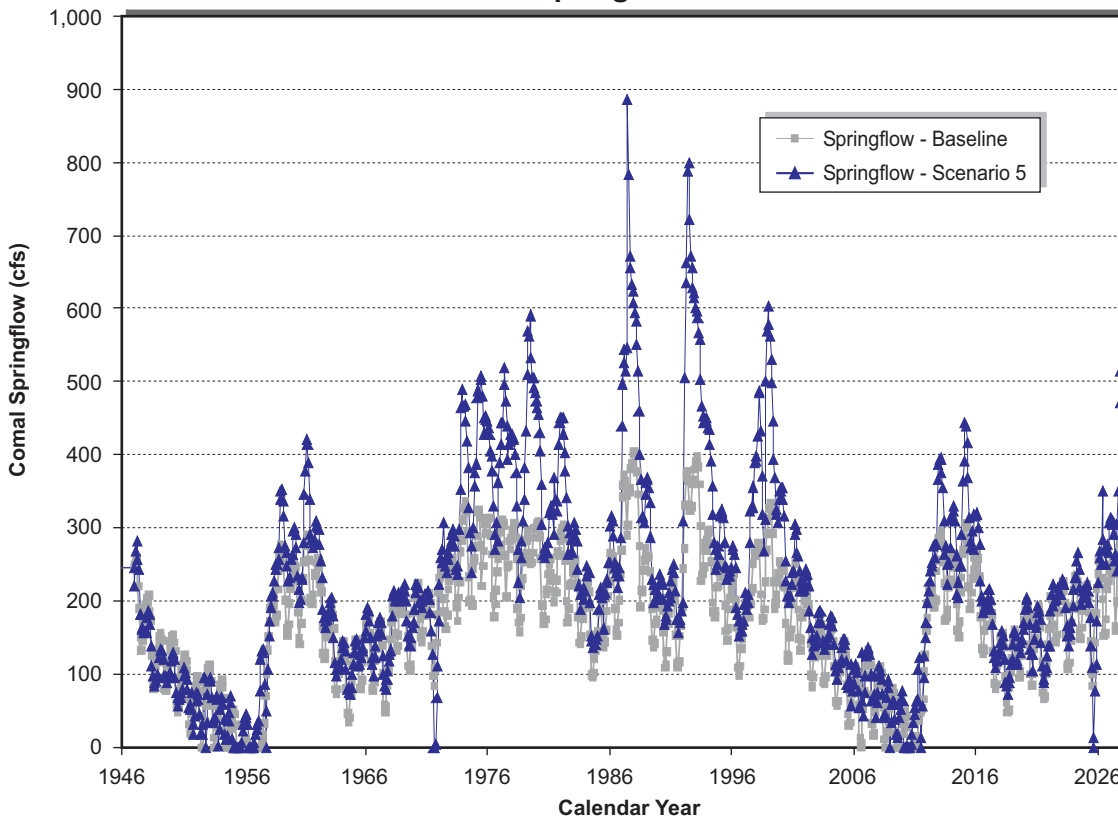

December 2008

TODD ENGINEERS
Alameda, California

Figure 7-11
Results of
Scenario 5

Excess Springflow Without Enhanced Pumping

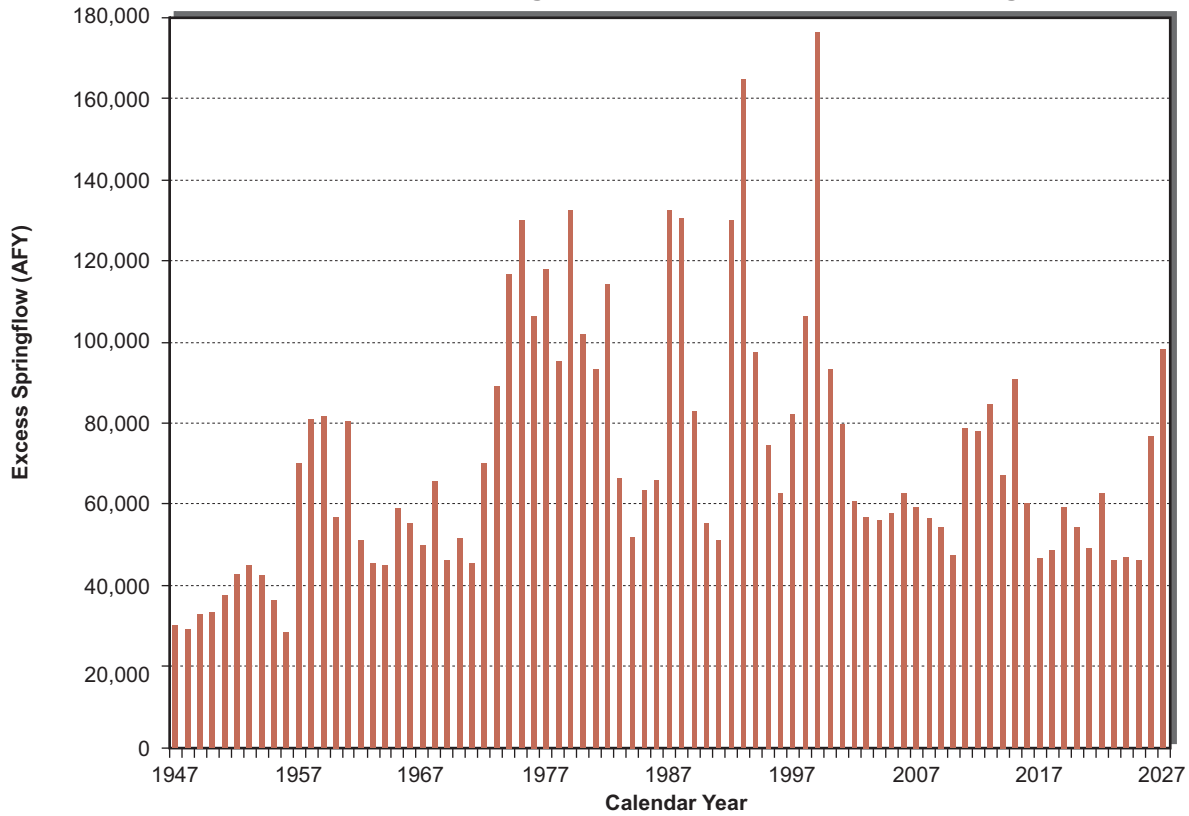

Excess Springflow With Enhanced Pumping

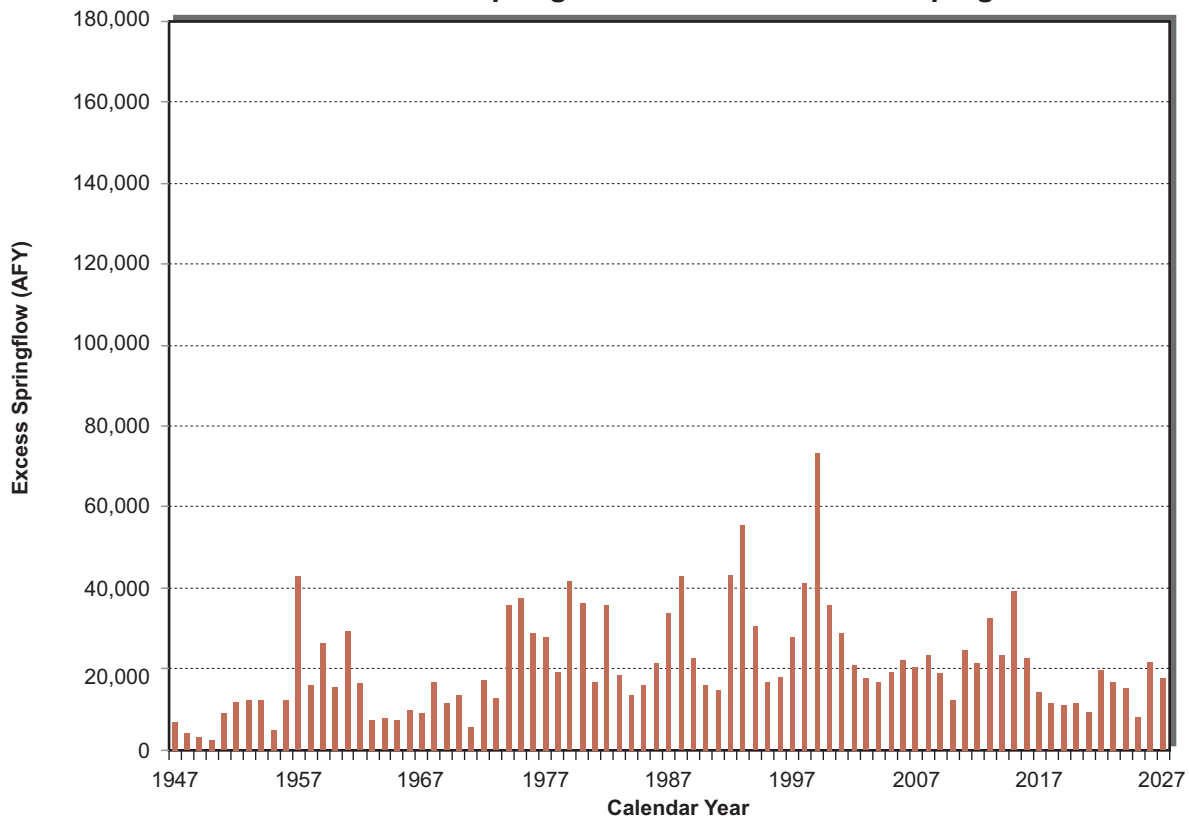

Note: Excess springflow on both graphs has been adjusted downward slightly based on preliminary sizing of Dunlap diversion pipeline.

December 2008

TODD ENGINEERS
Alameda, California

Figure 7-12
Range of Possible
Excess Springflow
for Recirculation

Annual Amounts of Enhanced Recharge Scenario 6

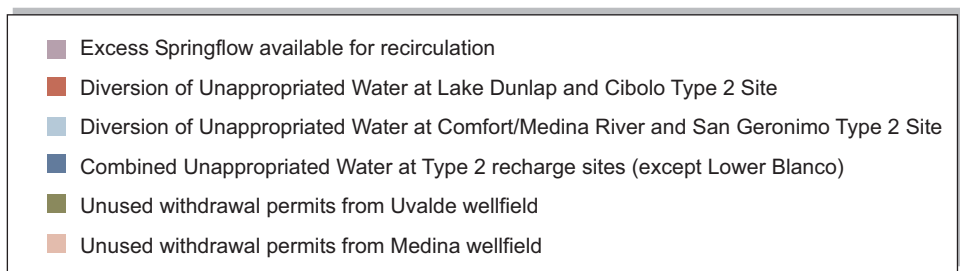
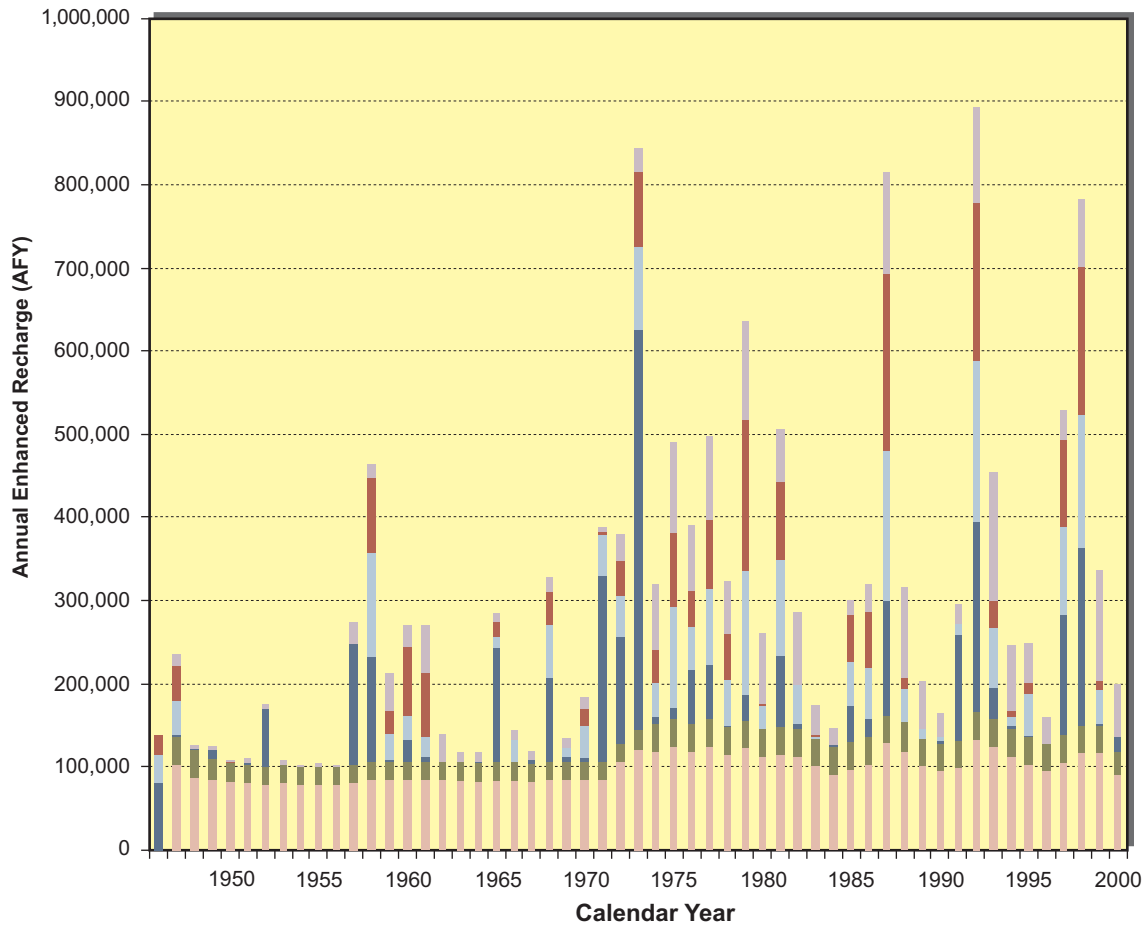

December 2008
TODD ENGINEERS Alameda, California

Figure 7-13 Enhanced Recharge for Scenario 6

Total Yield of Scenario 6

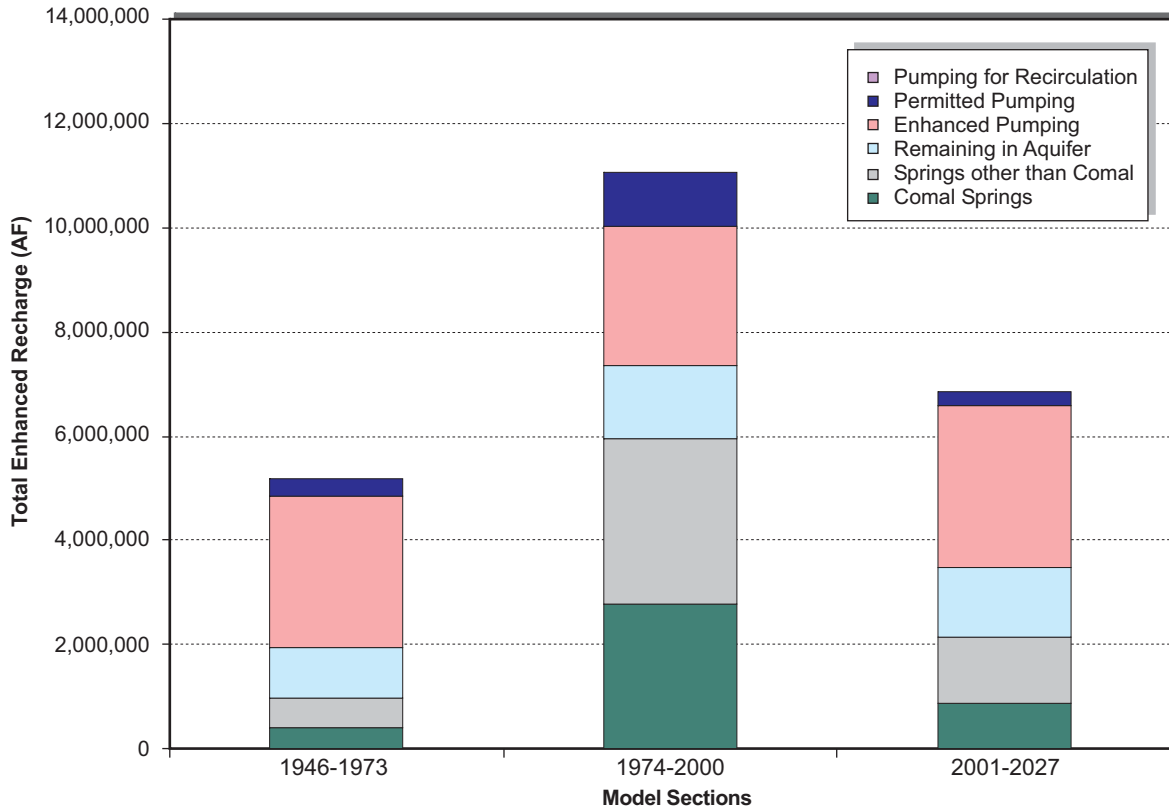

Comal Springs - Scenario 6

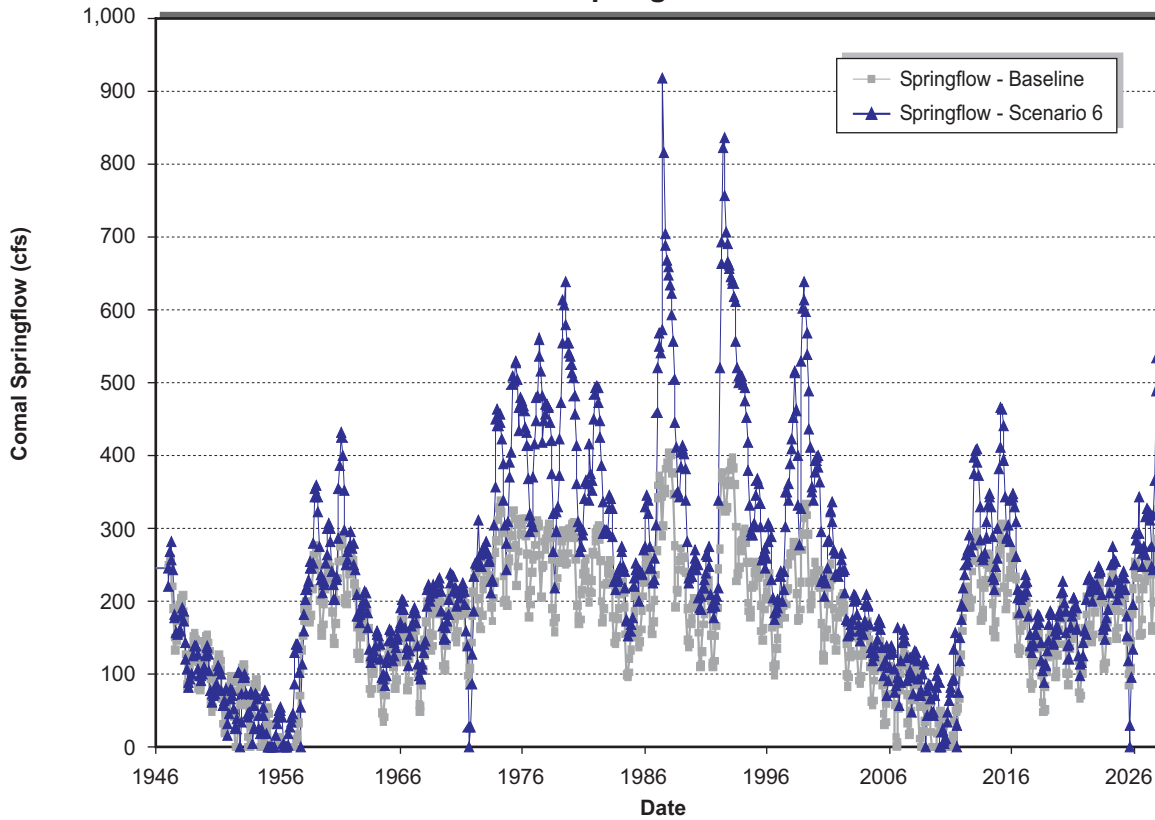

December 2008

TODD ENGINEERS
Alameda, California

Figure 7-14
Results of
Scenario 6

Annual Amounts of Enhanced Recharge for Scenario 7

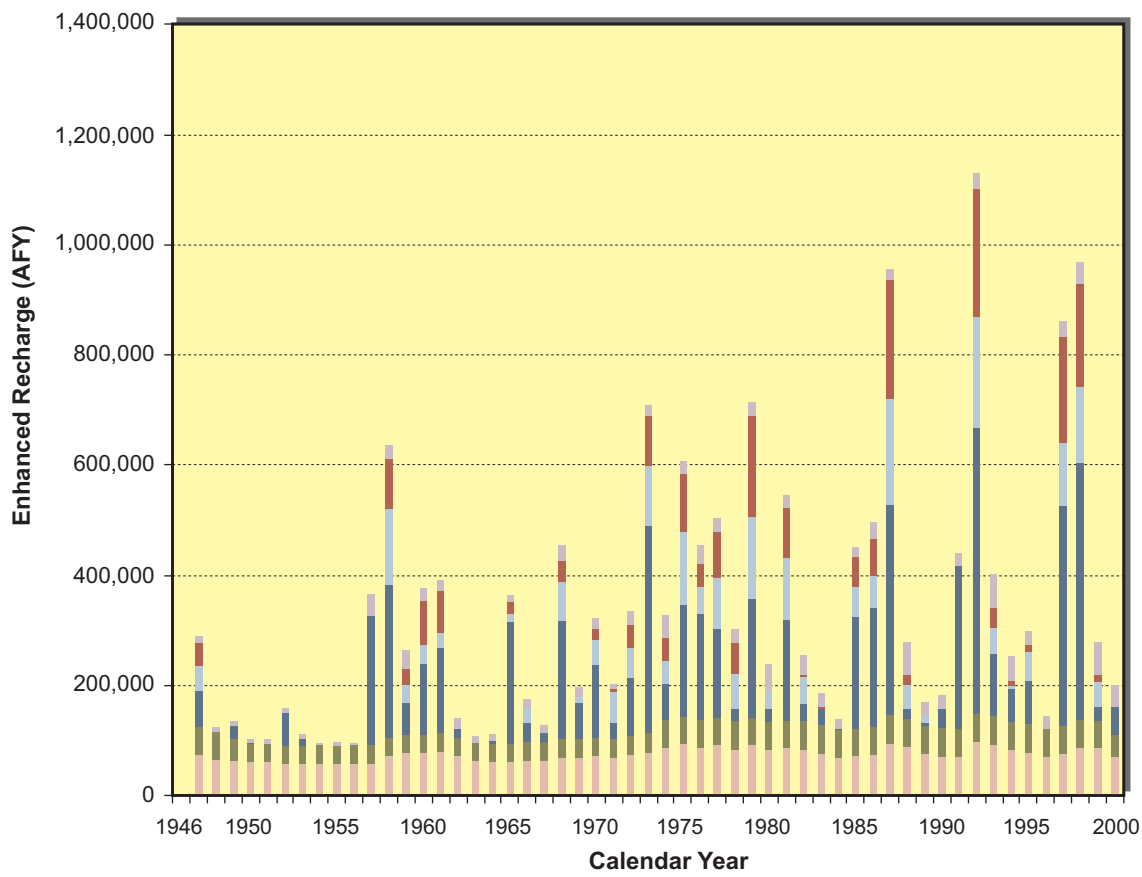

- Excess Springflow available for recirculation
- Diversion of Unappropriated Water at Lake Dunlap
- Diversion of Unappropriated Water at Comfort and Medina River
- Combined Unappropriated Water at selected Type 2 recharge sites
- Unused withdrawal permits from Uvalde wellfield
- Unused withdrawal permits from Medina wellfield

December 2008
 TODD ENGINEERS
 Alameda, California

Figure 7-15
Enhanced Recharge
for
Scenario 7

Total Yield of Scenario 7

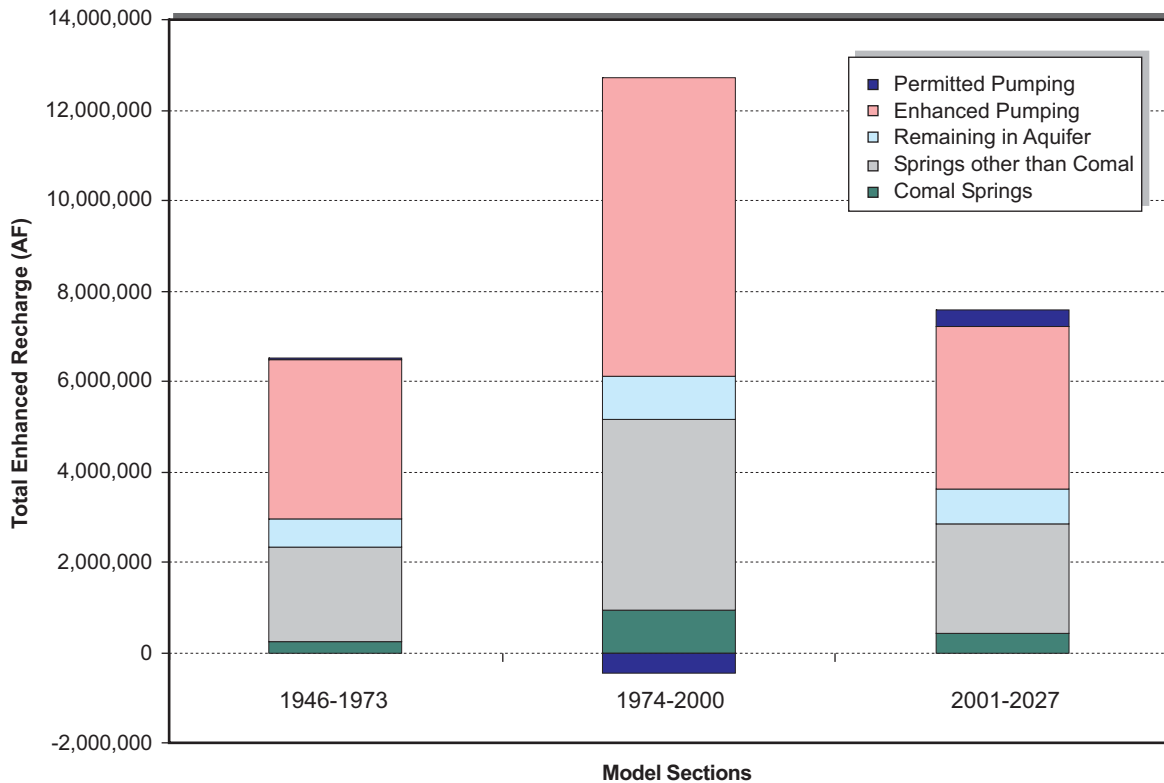

Comal Springs - Scenario 7

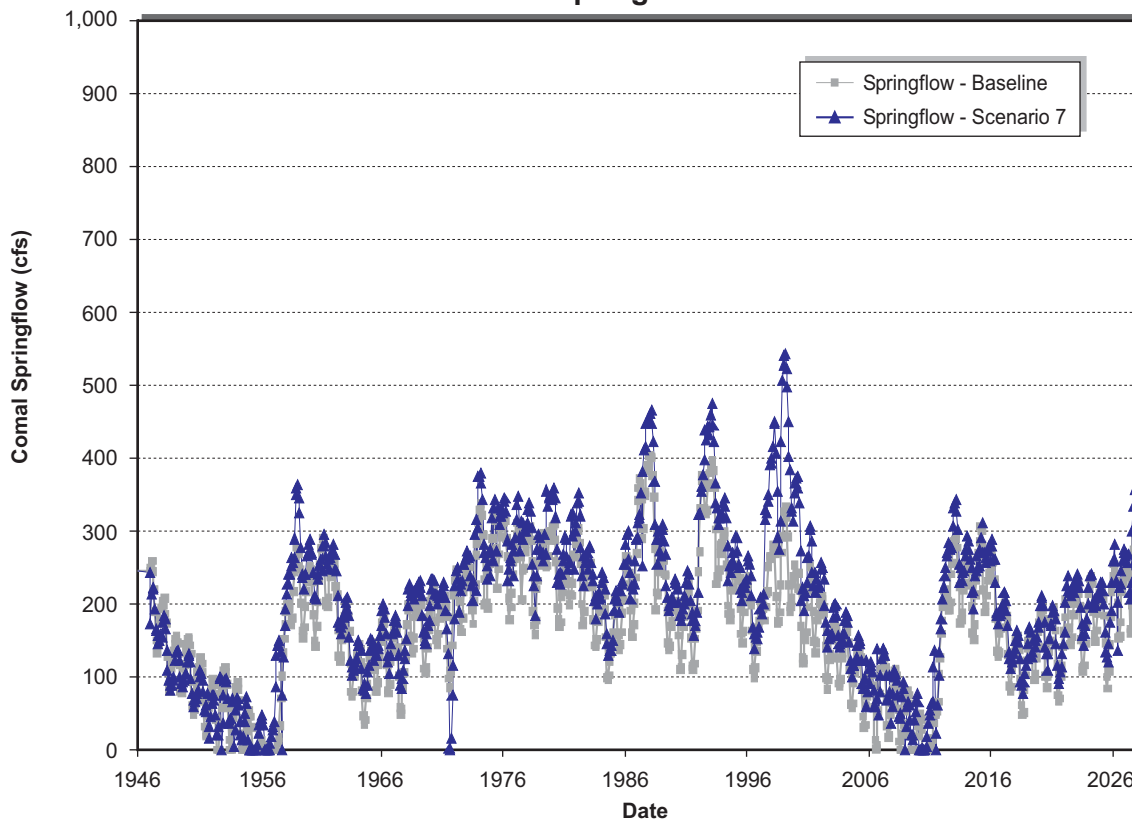

December 2008

TODD ENGINEERS
Alameda, California

Figure 7-16
Results
of Scenario 7

Enhanced Pumping for Recharge Recovery

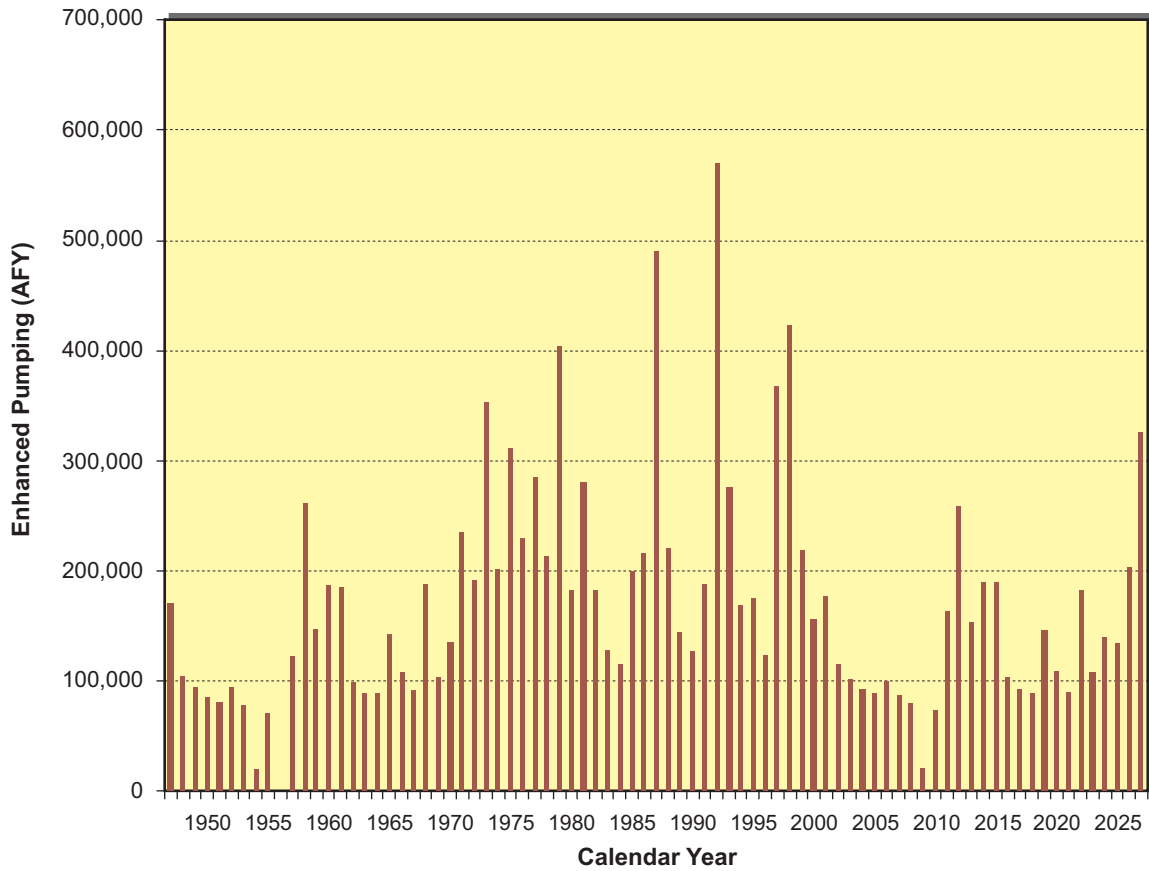

December 2008

TODD ENGINEERS
Alameda, California

Figure 7-17
Scenario 7
Enhanced Pumping
For Recharge Recovery

APPENDIX A

EXHIBIT A
SUPPLEMENT NO. 2

PHASE III and Phase IV SCOPE OF WORK
TO
CONTRACT NO. 04-152-AS

BETWEEN THE EDWARDS AQUIFER AUTHORITY
AND TODD ENGINEERS
FOR
ANALYSIS OF RECHARGE AND RECIRCULATION

Background Information

In April 2004, the Edwards Aquifer Authority (Authority) Board of Directors approved a contract between the Authority and Todd Engineers for the analysis of the concept of recharge and recirculation (R&R). The contract was structured such that the work would be completed in four phases and that the board must approve the scope of work for each phase prior to implementation. The four phases are:

Phase I	Definition of R&R Alternatives (completed in September 2004)
Phase II	Computer modeling of R&R Alternatives (completed in May 2005)
Phase III	Sizing of R&R Facilities
Phase IV	Summary, Recommendations, and Report Preparation

A principal tool of the analysis is the MODFLOW model of the Edwards Aquifer that has been prepared by the United States Geological Survey. Application of this model will enable multiple scenarios to be investigated regarding how recharge locations and volumes impact water levels and spring flows. With these data it will then be possible to evaluate the feasibility of various water collection, storage, and transport facilities.

Phase I was completed in September of 2004 and concluded that Phase II should be performed. Phase I was primarily to review R&R-related literature and to evaluate the recently completed Edwards Aquifer MODFLOW model to determine if the model would be an appropriate tool for the analysis. Two recharge scenarios were modeled in Phase I to test model response. Both scenarios predicted long-term storage benefits of up to several years when 25,000 acre feet was placed in the aquifer.

Phase II was completed in May 2005 and was performed, using the MODFLOW model, to simulate aquifer responses to recharge at eight different locations. The eight locations were the Type 2 recharge structure locations indicated in the 2001 South Central Texas Regional Water Planning Group (Region L) report. Numerous combinations of recharge timing, volume, and location were simulated. No specific source of the recharge water was considered in Phase I or II. Phase II simulations predicted that by recharging approximately 149,000 acre-feet of enhanced recharge and applying Authority Demand Management/Critical Period Management

(DM/CPM) rules during a repeat of the drought of record, Comal Springs could be kept from going dry.

Phase III will be conducted to evaluate potential operational parameters, water sources, and costs for various R&R scenarios. Completing and formatting the analysis pursuant to Texas Water Development Board guidelines for regional water plan development (planning guidelines) will also be performed in Phase III to allow regional water planners to consider R&R for inclusion in the Region L Regional Water Plan.

Findings of Phase II will be applied to develop scenarios under which the Edwards Aquifer, functioning as a reservoir, can meet water supply delivery and Comal Springs habitat requirements by means of R&R under assumed future conditions. The analysis will depend on specification of:

- location and magnitude of future pumpage as a function of time;
- Minimum Comal Springs flow requirements;
- Demand Management/Critical Period Management (DM/CPM) rules of the Authority applied to Initial Regular Permit (IRP); and
- Use of the Authority's Aquifer Storage and Recovery (ASR) Rules.

The Edwards Aquifer MODFLOW model will be used to evaluate:

- Locations of enhanced recharge;
- Quantity of water to be recharged;
- Locations and efficiency of enhanced recharge recovery/injection (recirculation) wells; and
- Quantity of water to be pumped for recirculation using ASR Rules.

Phase IV will be conducted in conjunction with Phase III in that the Phase III findings, which will build on the Phase I and Phase II findings, will be compiled into a final report in the Regional Water Planning format as was contemplated in the original contract as Phase IV. Task 5 of Supplement 2 will consist of the Phase IV report.

Project Team

For this project, Todd Engineers will subcontract with two experienced local firms, NRS Consulting Engineers and R.J. Brandes Company, providing extensive expertise in costing, surface water modeling, preliminary environmental analysis, and compliance with Texas Region Planning Guidelines. Todd Engineers will take the lead on groundwater modeling and well analysis and serve as project manager for the Phase III work. R.J. Brandes will lead on source water supply and the application of the Water Availability Model (WAM). Brandes will also will lead the preliminary environmental assessment in Task 3 and provide expertise on the application of water rights. NRS Consulting Engineers will oversee and assist on many tasks and will take the lead on engineering considerations (Task 4.1) and cost determinations (Task 4.2). Both NRS and Brandes will provide oversight for compliance with Region L guidelines where

applicable. All will participate in the preparation of the final report (Phase IV). Authority board approval of Supplement 2 also constitutes Authority approval of both NRS and Brandes as Todd Engineers subcontractors pursuant to Contract Article V.

Phase III – Sizing of R&R Facilities Scope of Work

The Phase III analysis will consist of the following tasks:

Task 1 – Develop Baseline Scenario (Todd)

Task 1.1 – Determine the baseline scenario to compare against recharge and R&R scenarios. Simulation of pumping in the model may be updated to reflect pumping volumes as defined in Region L planning procedures.

Baseline Scenario will include:

- Definition of “firm yield”
- Volume and distribution of pumping

Task 1.2 – Run baseline scenario as determined in Task 1.

Task 1.3 – Prepare a draft technical memorandum describing the baseline scenario and changes made to the model.

Task 1.4 – Present findings in a conference call

Task 1.5 – Modify baseline scenario based on input from conference call and revise technical memorandum for incorporation into final report.

Task 2 - Evaluate R&R Facility Operational Parameters (Todd)

Task 2.1 – Evaluate enhanced recharge requirements to maintain various requirements of springflow (Todd):

- Evaluate amount and location of enhanced recharge needed to maintain minimum springflow during average hydrologic conditions and the drought of record. Include:
 - Type 2 recharge sites evaluated in Phase II;
 - Seco Creek Sinkhole (location and details to be provided by the Authority).
- Perform the evaluation assuming minimum springflow requirements of 40 and 150 cubic feet per second (cfs) for Comal Springs.

Task 2.2 - Analyze recirculation options. This task will be a qualitative assessment for developing components for further analysis in Task 3. This task will consider only general availability and location of source water, including unused pumping amounts, as a more detailed analysis will be conducted in Task 3. (Todd)

- Evaluate the optimum placement of recirculation wells. Evaluation will consider various project criteria including recharge locations, impact to springflow, and length of pipelines. Initial placement will be based on analytical data and incorporate tracer tests, water level contour maps in the recharge zone, and other existing data identified by the Authority that would assist in the analysis. Three to six representative sites will be selected for further evaluation using the MODFLOW model.
- Evaluate the amount of water that can be pumped from recirculation wells in various locations without negatively affecting springflow at Comal Springs and San Marcos Springs in critical times. In order to compare combinations of recharge and recirculation locations, consistent amounts of recharge will be applied at each the Type II locations. This analysis builds on the work conducted in Phase II, where baseline data were generated. These baseline scenarios may need to be simulated again using the new baseline created from Task 1. The analysis will involve MODFLOW model runs and will be conducted during recent representative years of pumping patterns. The simulations will allow R&R scenarios to be compared to baseline simulations to determine the relative performance of each scenario.

Task 3 – Evaluation of source water availability and scenario modeling (Todd/NRS/Brandes)

Task 3.1 – Technical evaluation of potential source water supplies to include:

- Guadalupe River diversions (unappropriated and marketable) from Lake Dunlap (SCTN-6a and G-33), Comfort (G-30), Canyon Lake (G-32), and Medina Lake (S-13B) river diversions (NRS/Brandes). Consider;
 - Diversions from the Guadalupe River downstream of Comal Springs should be identified as the source water for springflow maintenance (Sec 1.30 issue);
- All Type 2 recharge structures identified in the Phase II analysis, including flood water pump-overs from Indian Creek and Lower Blanco (NRS/Brandes)
- Unused Edwards Aquifer withdrawal rights including (Todd/Authority):
 - Enhanced recharge withdrawal rights that would otherwise go unused; and
 - Municipal, Industrial, and Irrigation rights, that would otherwise go unused, availability to be assessed according to wet and dry years for regular withdrawal permits, junior rights, and IRP permits
 - Note: These amounts to be developed by the Authority staff with Todd assistance in application. It should be noted that the current MODFLOW model does not contain an easily modified well package that allows redistribution of pumping, in particular under the complex conditions of modifying pumping using withdrawal rights, junior rights, IRP permits, etc that vary in space and time. The Authority has developed management modules to assist in that effort, but current modules require the generation of a new well package for the model, a task beyond the scope of this project. It is our understanding that a new well package is being

generated, tested, and documented. If this work is complete and we can demonstrate the usefulness of the modules, they will be incorporated into this work. However, if modules are unproven or are difficult to manipulate, this analysis will not use the modules and will instead consist of a qualitative assessment of this source of water rather than on a well-by-well basis. However, in this task, Todd will work closely with the Authority to quantify the overall amounts of rights and permits that could add to the source of water for water supply.

Technical evaluations will consider:

- Consumptive and non-consumptive surface water rights with full subordination of hydro-electric rights and with both unappropriated rights and marketable rights as already incorporated into the WAM model;
- Surface water diversion rates on a monthly basis for the period of record;
- Regulations to protect springflow such as Edwards Aquifer withdrawal cap and Authority DM/CPM rules affecting IRPs and Junior Rights with the qualification that new well packages will not be developed under this scope (see Note above);
- Enhanced springflow diversion constraints such as surface water rights and §1.30 of the Edwards Aquifer Authority Act;
- Edwards Aquifer withdrawal right transfers; and
- Authority's ASR Rules applied to produce "firm yield" and minimum springflow in the most efficient manner.

Task 3.2 - Groundwater/surface water modeling of enhanced recharge (Todd/Brandes)

- Apply the Edwards Aquifer MODFLOW model with management modules (or modified input files capable of simulating effects of Critical Period rules) and surface water availability model (WAM) as needed to simulate effects of enhanced recharge on:
 - Authority DM/CPM rules
 - Enhanced springflow diversion constraints
 - Authority Aquifer, Storage, and Recovery Project rules
- In one scenario specify that any enhanced river flow due to enhanced recharge may be picked up by pumping it back to the recharge zone, if dedicated to minimum springflow and critical period downstream flow;
- In at least one scenario, the first source of water for maintaining springflow and downstream flow in critical times will be the diversions from the Guadalupe River below the springs.
- In one scenario, large monthly volumes available for recharge will be "held" and distributed over several months to provide a preliminary evaluation of the advantages of Type I structures over Type II structures.
- The general rule for modeling the use of ASR permits for enhanced recharge will generally minimize losses to springflow so as to produce as little enhanced surface water flow due to enhanced recharge as possible, with the exception for providing minimum

flow to Comal Springs and San Marcos Springs in critical times for that portion of recharge enhancement waters set aside for minimum springflow protection.

Task 3.3 – Simulate optimum recharge and recirculation (R&R) scenarios including an analysis of yield for preserving minimum springflow and yield for water supply (Todd)

- The most favorable scenarios for recharge and recirculation components as determined in Tasks 2.1 and 2.2 will be combined with various enhanced recharge volumes in Task 3.2 to develop a variety of R&R scenarios for simulation
- Scenarios will be analyzed for their impact on Comal Springs during critical times and the benefit to “firm yield” water supply.
- Available yield (water supply and springflow), both firm and average yield, calculations will be performed pursuant to planning guidelines (with assistance from NRS and the Authority on guideline application). Include benefit of withdrawal permit holders being excused from DM/CPM rules as one type of “firm yield” benefit, in addition to the Recharge Recover Right “firm yield” benefit using amounts generated in Task 3.1.

Task 3.4 – Evaluation of environmental issues (NRS with assistance from Brandes/Todd)

- An assessment of impacts on natural resources from the construction of R&R facilities will be performed pursuant to Regional Planning Guidelines.

Task 4– Engineering and cost estimating (NRS with assistance from Todd/Authority)

Task 4.1 – Engineering considerations

- Optimum R&R facility locations determined in Task 2 and source feasible information determined in Tasks 3 will be combined into several preferred R&R water management strategies for water supply and springflow maintenance.

Task 4.2 – Cost determinations

- Cost information for the preferred R&R water management strategy will be estimated pursuant to planning guidelines and include:
 - Firm yield unit costs for water supply and springflow maintenance unit costs;
 - Route selections;
 - Pipeline profiles;
 - Maps depicting all R&R facilities;
 - Capital equipment and maintenance costs including land acquisition, pipelines, transfer pump stations, intake structures, treatment plants, recharge dams, and water rights including mitigation costs for Corpus Christi; and
 - Cost spreadsheets.

Task 5 – Phase IV Report preparation in required regional water plan format (All)

Task 5.1 – Report preparation and formatting

- The results of Tasks 1, 2, and 3 will be compiled into a report (Contract Phase IV), formatted into the required regional water plan format and include the following:
 - Executive summary;
 - Description of information developed under each task including the development of the baseline scenario, which will serve as the comparison to additional R&R scenario analyses in this scope;
 - Available yield of preferred R&R water management strategies;
 - Environmental issues;
 - Engineering and costing information;
 - Implementation issues;
 - Changes in flow to affected springs, rivers, and estuaries;
 - Effects on downstream water rights;
 - Effects on yield of Canyon Reservoir; and
 - Presentation to Region L.

Task 5.2 – Project Management (Todd)

Throughout the project, Todd will be responsible for updating the Authority project manager on project status and identify any issues that may impact the analysis. Todd will compile invoices from subcontractors and provide a complete monthly invoice package demonstrating the progress of the work.

Task 6 – Potential integration into Regional Water Plan as a recommended strategy (Optional Task – to be developed after Task 5)

Task 6.1 – Regional Water Plan Amendment (if needed)

- If requested, the Regional Water Plan will be amended to include the R&R water management strategies by preparing the following:
 - Executive summary describing the proposed amendment;
 - Water supply plans;
 - Cumulative effects on Regional Water Plan implementation;
 - Environmental assessment; and
 - Responses to Region L, Texas Water Development Board, state, federal, and public comments.

Schedule

Other than Task 6, the Phase III and Phase IV work will be performed over a nine-month period plus any time for work on modifications that may be requested by the Authority. The nine-month performance period will begin once the Authority and the Contractor execute the

Supplement No. 2 approval letter and the Authority has notified the team with authorization to proceed. The schedule and need for Task 6 will be determined after completion of Task 5.

For reference, the Phase III and IV general scopes of work provided in the original Contract are as follows:

Phase III - Sizing of R&R Facilities

1. Determine optimum size and location of selected recharge facilities.
2. Identify operational parameters of water management facilities in relation to timing and goals.
3. Estimate costs for selected facilities using SCTRWPG methods.

Phase IV - Summary, Recommendations, and Report

1. Document and summarize results in a report employing SCTRWPG formats.
2. Recommend subsequent steps to ensure compatibility with other regional water goals and needs.

APPENDIX B

UNAPPROPRIATED FLOWS AT GUADALUPE RIVER AT COMFORT (AF)
Simulated with San Antonio-Guadalupe Water Availability Model (Run 3 Modified for 2007 Pumping Rules)

YEAR*	JAN	FEB	MAR	APR	MAY	JUN	JUL	AUG	SEP	OCT	NOV	DEC	TOTAL
1934	49	0	0	0	0	0	0	0	0	0	0	0	49
1935	0	0	0	0	0	0	0	0	103	2,610	3,440	1	6,154
1936	3,188	6,169	1,619	0	13,634	0	114	0	0	265	0	0	24,989
1937	0	14,915	8,470	0	0	3,897	0	0	0	0	0	0	27,282
1938	0	0	0	780	0	0	0	0	0	0	0	0	780
1939	0	0	0	0	0	0	0	0	0	0	0	0	0
1940	0	0	0	0	0	0	0	0	0	0	0	0	0
1941	0	0	0	92	98	8,323	3,866	0	0	12,956	4,642	4,073	34,050
1942	0	0	0	0	0	2,891	0	0	574	11,209	4,068	3,632	22,374
1943	2,241	0	0	0	0	4,452	0	0	0	0	0	0	6,693
1944	0	0	3,714	418	204	14,510	0	99	2,131	3,696	1	7,922	32,695
1945	1	12,765	0	15,378	2,898	0	0	0	3,250	0	0	6,228	40,520
1946	3,284	3,485	2,303	1,411	7,526	774	0	0	0	9,911	68	7,518	36,280
1947	1	10,137	7,160	7,652	5,751	17,096	0	0	0	0	0	0	47,797
1948	0	641	0	0	0	0	0	0	0	0	0	0	641
1949	0	0	0	0	0	0	0	0	0	0	0	0	0
1950	0	0	0	0	0	0	0	0	0	0	0	0	0
1951	0	0	0	0	0	0	0	0	0	0	0	0	0
1952	0	0	0	0	0	0	0	0	0	0	0	0	0
1953	0	0	0	0	0	0	0	0	0	0	0	0	0
1954	0	0	0	0	0	0	0	0	0	0	0	0	0
1955	0	0	0	0	0	0	0	0	0	0	0	0	0
1956	0	0	0	0	0	0	0	0	0	0	0	0	0
1957	0	0	0	0	0	0	0	0	0	0	0	0	0
1958	0	0	25	8,773	9,252	14,290	845	0	25,385	3	9,667	8,076	76,316
1959	5,963	1	580	5,258	1,790	16,960	0	0	0	294	3,063	3,025	36,934
1960	4,790	8,504	3,974	1,917	0	0	0	30,052	0	196	8	1	49,442
1961	6	0	0	8,042	2,666	1	4,040	0	0	0	0	0	14,755
1962	0	0	0	0	0	0	0	0	0	0	0	0	0
1963	0	0	0	0	0	0	0	0	0	0	0	0	0
1964	0	0	0	0	0	0	0	0	0	0	0	0	0
1965	0	0	0	0	0	15,243	0	0	0	0	0	0	15,243
1966	530	611	0	3,750	0	0	0	22,946	7,878	0	0	0	35,715
1967	0	0	0	0	0	0	0	0	0	0	0	0	0
1968	0	13,848	16,019	15,384	15,130	5,977	3,991	0	0	0	0	0	70,349
1969	0	0	0	0	0	0	0	0	0	0	10,506	0	10,506
1970	7,918	0	15,126	7,262	10,887	3,808	393	0	0	0	0	0	45,394
1971	0	0	0	0	0	0	0	0	5,665	0	14,419	10,684	30,768
1972	7,566	6,010	1,897	0	121	7,165	2,570	9,834	0	0	1,525	0	36,688
1973	2,358	1	5,021	3,910	1,141	3,695	19,248	6,996	8	1	10,583	7,313	60,275
1974	6,458	3,705	2,467	21	96	203	0	22,995	20,923	0	125	0	56,993
1975	0	0	16,833	12,573	3	30,925	13,736	5,787	0	0	0	0	79,857
1976	0	0	0	2,756	3,281	1,496	16,245	2,121	0	6,108	7,074	9,909	48,990
1977	10,491	8,006	5,136	5	35	9,922	3,317	0	0	0	0	0	36,912
1978	0	0	0	0	0	0	0	100	3	10,660	3	7,865	18,631
1979	10,736	0	0	0	17,255	109	13,277	9,070	0	0	0	0	50,447
1980	1,948	0	404	0	1,266	0	0	0	0	17,630	5,506	7,317	34,071
1981	5,397	4,221	76	118	0	5	20,818	8,253	8,342	3	14,988	10,934	73,155
1982	8,242	6,164	5,028	2,210	17,632	12,899	0	0	0	0	0	0	52,175
1983	0	0	0	0	0	1,336	0	0	0	0	0	0	1,336
1984	0	0	0	0	0	0	0	0	0	0	0	0	0
1985	0	11,678	16,384	9,635	0	4,409	3,926	0	0	312	0	10,566	56,910
1986	7,808	12,797	1,911	1,228	1	16,825	2,750	0	19,176	2	0	4	62,502
1987	95	3	20	15,727	8	3	164	22,690	17,515	11,605	11,411	11,143	90,384
1988	9,234	7,172	5,098	0	8,610	3,039	0	11,457	0	0	0	0	44,610
1989	0	5,204	4,613	2,799	0	0	0	0	0	0	0	0	12,616
1990	0	0	0	0	0	0	0	0	0	0	0	0	0
1991	0	0	0	0	0	0	0	0	0	0	0	0	0
1992	0	90,446	87,079	48,597	42,827	38,739	19,711	11,290	6,991	5,672	10,121	9,312	370,784
1993	0	0	9,702	8,731	6,807	4,224	1,128	0	0	0	0	0	30,592
1994	0	0	0	0	0	4,401	0	0	1,429	0	0	0	5,830
1995	0	0	8,055	5,746	8,554	11,307	4,182	0	4,463	2,394	4,580	2,649	51,931
1996	0	0	0	0	0	0	0	0	0	0	0	0	0
1997	0	0	25,783	39,858	29,864	146,450	34,994	13,123	6,997	7,871	5,200	4,878	315,019
1998	8,948	8,442	25,065	9,542	4,079	1,641	0	13,244	0	9,169	13,678	9,883	103,692
1999	6,416	3,544	6,213	4,475	5,520	7,532	3,873	0	0	0	0	0	37,574
2000	0	0	0	0	0	0	0	0	0	0	0	0	0
AVG	1,697	3,559	4,265	3,643	3,238	6,187	2,585	2,837	1,953	1,680	2,010	2,133	35,787
MAX	10,736	90,446	87,079	48,597	42,827	146,450	34,994	30,052	25,385	17,630	14,988	11,143	370,784
MIN	0	0	0	0	0	0	0	0	0	0	0	0	0

*Years 1934-1989 extracted from the WAM model
 *Years 1990-2000 filled in using linear regression with streamflow gage and Canyon Lake storage

Correlation Equation: $y = 0.9597x - 4938.1$ R²: 0.97
 Streamflow Gage: Guadalupe River at Comfort

UNAPPROPRIATED WATER IN THE GUADALUPE RIVER AT CANYON LAKE (AF)
Simulated with San Antonio-Guadalupe Water Availability Model (Run 3 Modified for 2007 Pumping Rules)

YEAR	JAN	FEB	MAR	APR	MAY	JUN	JUL	AUG	SEP	OCT	NOV	DEC	TOTAL
1934	39	0	0	0	0	0	0	0	0	0	0	0	39
1935	0	0	0	0	0	173704	0	0	2878	0	0	0	176582
1936	0	0	0	0	0	0	55037	0	157687	31021	0	0	243745
1937	0	0	0	0	0	273	0	0	0	0	0	0	273
1938	0	0	0	0	0	0	0	0	0	0	0	0	0
1939	0	0	0	0	0	0	0	0	0	0	0	0	0
1940	0	0	0	0	0	0	0	0	0	0	0	0	0
1941	0	0	26358	63643	95060	6482	0	0	0	0	0	0	191543
1942	0	0	0	0	0	0	0	0	0	11191	0	0	11191
1943	0	0	0	0	0	0	0	0	0	0	0	0	0
1944	0	0	2169	0	67195	5513	0	0	0	0	1	3	74881
1945	17881	22368	35807	20798	0	0	0	0	0	0	0	0	96854
1946	0	0	0	0	0	0	0	0	0	0	23401	8049	31450
1947	36809	3385	0	0	0	0	0	0	0	0	0	0	40194
1948	0	0	0	0	0	0	0	0	0	0	0	0	0
1949	0	0	0	0	0	0	0	0	0	0	0	0	0
1950	0	0	0	0	0	0	0	0	0	0	0	0	0
1951	0	0	0	0	0	0	0	0	0	0	0	0	0
1952	0	0	0	0	0	0	0	0	0	0	0	0	0
1953	0	0	0	0	0	0	0	0	0	0	0	0	0
1954	0	0	0	0	0	0	0	0	0	0	0	0	0
1955	0	0	0	0	0	0	0	0	0	0	0	0	0
1956	0	0	0	0	0	0	0	0	0	0	0	0	0
1957	0	0	0	0	0	0	0	0	0	0	0	0	0
1958	0	14639	35788	0	72480	0	0	0	0	2	0	0	122909
1959	0	1	0	0	0	0	0	0	0	26249	0	0	26250
1960	0	0	0	0	0	0	0	0	0	62193	15594	26458	104245
1961	22078	51268	13316	0	0	1	0	0	0	0	0	0	86663
1962	0	0	0	0	0	0	0	0	0	0	0	0	0
1963	0	0	0	0	0	0	0	0	0	0	0	0	0
1964	0	0	0	0	0	0	0	0	0	0	0	0	0
1965	0	0	0	0	15757	18593	0	0	0	0	0	0	34350
1966	0	0	0	0	0	0	0	0	0	0	0	0	0
1967	0	0	0	0	0	0	0	0	0	0	0	0	0
1968	100064	11867	5871	7294	12128	0	0	0	0	0	0	0	137224
1969	0	0	0	0	0	0	0	0	0	0	0	0	0
1970	0	0	12049	0	29857	0	0	0	0	0	0	0	41906
1971	0	0	0	0	0	0	0	0	0	2978	0	905	3883
1972	0	0	0	0	84653	0	0	0	0	0	0	0	84653
1973	0	1	0	2	0	15066	94539	0	7	77238	3626	0	190479
1974	0	0	0	0	9644	0	0	0	0	0	30925	369	40938
1975	0	74632	12643	2304	89132	39699	7010	0	0	0	0	0	225420
1976	0	0	0	13086	20568	0	0	0	0	16028	8020	15477	73179
1977	8153	10661	0	128907	42872	0	0	0	0	0	0	0	190593
1978	0	0	0	0	0	0	0	175393	15673	0	2	0	191068
1979	24780	27242	63525	58500	37892	56055	1972	0	0	0	0	0	269966
1980	0	0	0	0	0	0	0	0	0	0	0	0	0
1981	0	0	5281	6400	0	169508	0	0	0	41071	0	0	222260
1982	0	0	0	0	10757	0	0	0	0	0	0	0	10757
1983	0	0	0	0	0	0	0	0	0	0	0	0	0
1984	0	0	0	0	0	0	0	0	0	0	0	0	0
1985	0	0	9159	0	0	45320	0	0	0	15066	0	0	69545
1986	0	0	0	0	1	731	0	0	0	22460	5829	90133	119154
1987	36557	25236	32390	1037	46299	365155	89994	10318	0	0	0	0	606986
1988	0	0	0	0	0	0	0	0	0	0	0	0	0
1989	0	0	0	0	0	0	0	0	0	0	0	0	0
1990	0	0	0	0	0	0	0	0	0	0	0	0	0
1991	0	0	0	0	0	0	0	0	0	0	0	0	0
1992	0	65471	132294	120113	77631	90227	32058	18684	10851	6978	8483	14044	576834
1993	0	0	18439	14887	13718	9422	6770	4067	0	0	0	0	67304
1994	0	0	0	0	0	16462	5659	3389	3553	0	0	0	29062
1995	0	0	10932	12122	7843	19256	13707	4540	3730	4643	6333	5999	89107
1996	0	0	0	0	0	0	0	0	0	0	0	0	0
1997	0	0	28745	54924	38505	63654	177861	40167	13203	7130	6730	8378	439296
1998	12018	21069	46862	19652	9401	8409	4958	5884	0	6007	49014	71050	254323
1999	14303	7225	5554	5355	5637	7404	10688	4747	3284	3351	0	0	67550
2000	0	0	0	0	0	0	0	0	0	0	0	0	0
AVG	4,070	5,001	7,421	7,896	11,747	16,581	7,466	3,988	3,147	4,979	2,358	3,595	78,249
MAX	100,064	74,632	132,294	128,907	95,060	365,155	177,861	175,393	157,687	77,238	49,014	90,133	606,986
MIN	0	0	0	0	0	0	0	0	0	0	0	0	0

*Years 1934-1989 extracted from the WAM model
 *Years 1990-2000 filled in using linear regression with streamflow gage and Canyon Lake storage

Correlation Equation: $y = 0.5449x - 16.251$ R²: 0.53
 Streamflow Gage: Guadalupe River at Sattler

UNAPPROPRIATED WATER IN THE COMAL RIVER DOWNSTREAM OF COMAL SPRINGS (AF)
Simulated with San Antonio-Guadalupe Water Availability Model (Run 3 Modified for 2007 Pumping Rules)

YEAR	JAN	FEB	MAR	APR	MAY	JUN	JUL	AUG	SEP	OCT	NOV	DEC	TOTAL
1934	39	0	0	0	0	0	0	0	0	0	0	0	39
1935	65	0	0	2298	9	15065	0	0	2873	0	0	0	20,310
1936	0	0	0	424	0	0	15437	0	14771	15064	0	0	45,696
1937	0	0	0	0	1	272	0	582	184	0	1158	0	2,197
1938	0	0	0	0	0	0	0	2104	903	5928	2736	3180	14,851
1939	0	3091	895	284	0	0	0	0	0	0	0	0	4,270
1940	0	0	738	0	0	0	0	0	0	0	0	0	738
1941	0	0	13458	18351	20549	6471	0	0	0	0	0	0	58,829
1942	0	0	0	0	0	0	1	32	0	11172	0	0	11,205
1943	0	0	0	0	0	0	0	292	3140	2981	866	43	7,322
1944	0	0	2165	0	16894	5503	0	536	0	0	1	3	25,102
1945	15924	16128	18677	17714	0	0	0	0	0	0	0	0	68,443
1946	0	0	0	0	0	0	0	0	0	0	16392	8035	24,427
1947	16171	3379	0	0	0	0	0	0	159	2542	2301	0	24,552
1948	0	0	0	0	0	0	0	0	0	0	0	0	0
1949	0	0	0	2	0	0	0	0	0	0	0	0	2
1950	0	0	285	0	0	0	0	0	0	0	0	0	285
1951	0	0	0	0	0	0	0	0	0	0	0	0	0
1952	0	0	0	0	0	0	0	0	0	0	0	0	0
1953	0	0	0	0	0	0	0	0	0	0	0	0	0
1954	0	0	0	0	0	0	0	0	0	0	0	0	0
1955	0	0	0	0	0	0	0	0	0	0	0	0	0
1956	0	0	0	0	0	0	0	0	0	0	0	0	0
1957	0	0	0	0	0	0	0	0	0	0	0	0	0
1958	0	13279	12010	0	12545	0	0	1130	0	2	0	0	38,966
1959	0	1	0	0	0	0	0	0	1638	14006	0	0	15,645
1960	0	0	0	0	0	0	0	0	0	20614	14506	16643	51,763
1961	17012	16140	13293	0	0	1	0	0	0	0	0	0	46,446
1962	0	0	0	0	0	0	0	0	0	0	0	0	0
1963	0	0	0	0	0	0	0	0	0	0	0	0	0
1964	0	0	0	0	0	0	0	0	0	0	0	0	0
1965	0	0	0	0	16219	5838	0	0	0	0	0	0	22,057
1966	0	0	0	0	0	0	0	0	0	0	0	0	0
1967	0	0	0	0	0	0	0	0	0	0	0	0	0
1968	23837	11425	5861	7282	11235	0	0	0	0	0	0	0	59,640
1969	0	0	0	0	0	0	0	0	0	0	0	0	0
1970	0	0	12028	0	16615	0	0	0	0	0	0	320	28,963
1971	0	1301	375	0	0	0	0	0	0	2973	0	904	5,553
1972	0	0	0	1424	49710	0	0	0	0	0	0	0	51,134
1973	0	1	0	2	0	14364	14733	0	7	18506	3620	0	51,233
1974	0	0	0	0	9627	0	0	0	0	0	21785	369	31,781
1975	0	18000	12622	2300	26180	15195	6998	0	0	0	0	0	81,295
1976	0	0	0	13064	19748	0	0	0	0	16001	8006	15451	72,270
1977	8139	10643	0	23943	17358	0	0	0	0	0	0	0	60,083
1978	0	0	0	0	0	0	0	10385	14302	0	2	0	24,689
1979	17446	15768	19124	19192	17393	15291	1968	0	0	0	0	0	106,182
1980	0	0	0	1650	0	0	0	0	0	0	0	0	1,650
1981	0	0	5272	6390	0	19473	0	0	0	17069	0	0	48,204
1982	0	0	0	0	10738	0	0	0	0	1517	0	0	12,255
1983	0	0	0	0	0	0	0	0	1247	0	0	1703	2,950
1984	0	0	0	0	0	0	0	0	0	0	0	0	0
1985	0	0	9144	0	0	11209	0	0	562	12751	0	0	33,666
1986	0	0	0	0	1	730	0	0	0	14830	5819	27433	48,813
1987	21946	23346	22712	1035	21131	28397	20571	10301	0	0	0	0	149,439
1988	0	0	0	0	0	0	0	0	199	3988	3823	6421	14,431
1989	0	0	0	0	0	0	0	0	0	0	0	0	0
1990	0	0	0	0	0	0	0	0	0	0	0	0	0
1991	0	0	0	0	0	0	0	0	0	0	0	0	0
1992	0	21774	41183	35907	23924	27775	10671	6956	4496	3310	3760	5740	185,498
1993	0	0	7319	5799	6720	4580	3494	2269	0	0	0	0	30180
1994	0	0	0	0	0	5789	2161	1564	1666	0	0	0	11179
1995	0	0	3631	4416	3372	7046	4669	1886	1656	1843	2392	2209	33120
1996	0	0	0	0	0	0	0	0	0	0	0	0	0
1997	0	0	9403	15752	11829	20955	50573	12460	4747	3050	2696	3132	134,597
1998	4693	8156	14927	7638	3476	2964	2109	2478	0	16823	16007	21846	101,116
1999	5877	3425	2830	2712	2523	3038	3866	2008	1463	1499	0	0	29,242
2000	0	0	0	0	0	0	0	0	0	0	0	0	0
AVG	1,957	2,475	3,402	2,800	4,743	3,134	2,049	821	806	2,783	1,580	1,693	28,243
MAX	23,837	23,346	41,183	35,907	49,710	28,397	50,573	12,460	14,771	20,614	21,785	27,433	185,498
MIN	0	0	0	0	0	0	0	0	0	0	0	0	0

*Years 1934-1989 extracted from the WAM model
 *Years 1990-2000 filled in using linear regression with streamflow gage and Canyon Lake storage

Correlation Equation: $y = 0.1556x + 479.49$ R²: 0.57
 Streamflow Gage: Guadalupe River at New Braunfels

UNAPPROPRIATED WATER IN THE GUADALUPE RIVER AT LAKE DUNLAP(AF)
Simulated with San Antonio-Guadalupe Water Availability Model (Run 3 Modified for 2007 Pumping Rules)

YEAR	JAN	FEB	MAR	APR	MAY	JUN	JUL	AUG	SEP	OCT	NOV	DEC	TOTAL
1934	39	0	0	0	0	0	0	0	0	0	0	0	39
1935	65	0	0	2296	9	173305	0	0	2871	0	0	0	178,546
1936	0	0	0	424	0	0	56925	0	157325	30949	0	0	245,623
1937	0	0	0	0	1	272	0	581	183	0	1158	0	2,195
1938	0	0	0	0	0	0	0	2102	903	5925	2734	3178	14,842
1939	0	3089	895	284	0	0	0	0	0	0	0	0	4,268
1940	0	0	738	0	0	0	0	0	0	0	0	0	738
1941	0	0	26298	63497	94841	6467	0	0	0	0	0	0	191,103
1942	0	0	0	0	0	0	1	32	0	11165	0	0	11,198
1943	0	0	0	0	0	0	0	292	3138	2979	865	43	7,317
1944	0	0	2164	0	67041	5500	0	536	0	0	1	3	75,245
1945	17840	22317	35725	20750	0	0	0	0	0	0	0	0	96,632
1946	0	0	0	0	0	0	0	0	0	0	23347	8030	31,377
1947	36724	3377	0	0	0	0	0	0	159	2540	2300	0	45,100
1948	0	0	0	0	0	0	0	0	0	0	0	0	0
1949	0	0	0	2	0	0	0	0	0	0	0	0	2
1950	0	0	285	0	0	0	0	0	0	0	0	0	285
1951	0	0	0	0	0	0	0	0	0	0	0	0	0
1952	0	0	0	0	0	0	0	0	0	0	0	0	0
1953	0	0	0	0	0	0	0	0	0	0	0	0	0
1954	0	0	0	0	0	0	0	0	0	0	0	0	0
1955	0	0	0	0	0	0	0	0	0	0	0	0	0
1956	0	0	0	0	0	0	0	0	0	0	0	0	0
1957	0	0	0	0	0	0	0	0	0	0	0	0	0
1958	0	14605	35705	0	72313	0	0	1129	0	2	0	0	123,754
1959	0	1	0	0	0	0	0	0	1637	26189	0	0	27,827
1960	0	0	0	0	0	0	0	0	0	62050	15558	26397	104,005
1961	22028	51151	13285	0	0	1	0	0	0	0	0	0	86,465
1962	0	0	0	0	0	0	0	0	0	0	0	0	0
1963	0	0	0	0	0	0	0	0	0	0	0	0	0
1964	0	0	0	0	0	0	0	0	0	0	0	0	0
1965	0	0	0	0	16210	18550	0	0	0	0	0	0	34,760
1966	0	0	0	0	0	0	0	0	0	0	0	0	0
1967	0	0	0	0	0	0	0	0	0	0	0	0	0
1968	99834	11839	5858	7277	12100	0	0	0	0	0	0	0	136,908
1969	0	0	0	0	0	0	0	0	0	0	0	0	0
1970	0	0	12021	0	29788	0	0	0	0	0	0	320	42,129
1971	0	1301	375	0	0	0	0	0	0	2971	0	903	5,550
1972	0	0	0	1423	121472	0	0	0	0	0	0	0	122,895
1973	0	1	0	2	0	15032	94321	0	7	77060	3618	0	190,041
1974	0	0	0	0	9622	0	0	0	0	0	30854	369	40,845
1975	0	74461	12614	2298	88927	39607	6994	0	0	0	0	0	224,901
1976	0	0	0	13056	20521	0	0	0	0	15991	8001	15442	73,011
1977	8134	10636	0	128611	42774	0	0	0	0	0	0	0	190,155
1978	0	0	0	0	0	0	0	174989	15637	0	2	0	190,628
1979	24723	27179	63379	58365	37805	55926	1967	0	0	0	0	0	269,344
1980	0	0	0	1649	0	0	0	0	0	0	0	0	1,649
1981	0	0	5269	6386	0	169118	0	0	0	40977	0	0	221,750
1982	0	0	0	0	10732	0	0	0	0	1516	0	0	12,248
1983	0	0	0	0	0	0	0	0	1247	0	0	1702	2,949
1984	0	0	0	0	0	0	0	0	0	0	0	0	0
1985	0	0	9138	0	0	45216	0	0	562	15032	0	0	69,948
1986	0	0	0	0	1	730	0	0	0	22409	5815	89926	118,881
1987	36473	25178	32316	1034	46192	364316	89787	10294	0	0	0	0	605,590
1988	0	0	0	0	0	0	0	0	199	3985	3820	6418	14,422
1989	0	0	0	0	0	0	0	0	0	0	0	0	0
1990	0	0	0	0	0	0	0	0	0	0	0	0	0
1991	0	0	0	0	0	0	0	0	0	0	0	0	0
1992	0	84478	170309	146978	93988	111019	35380	18952	8071	2827	4817	13574	690,394
1993	0	0	20555	13835	17906	8442	3638	0	0	0	0	0	64,377
1994	0	0	0	0	0	13787	0	0	0	0	0	0	13,787
1995	0	0	4247	7716	3100	19350	8835	0	0	0	0	0	43,249
1996	0	0	0	0	0	0	0	0	0	0	0	0	0
1997	0	0	29771	57846	40501	80857	211834	43292	9181	1678	110	2039	477,109
1998	8941	24255	54201	21965	3562	1295	0	0	0	62582	58974	84798	320,572
1999	14180	3337	702	182	0	1624	5287	0	0	0	0	0	25,312
2000	0	0	0	0	0	0	0	0	0	0	0	0	0
AVG	4,015	5,331	7,998	8,297	12,379	16,872	7,686	3,764	3,002	5,803	2,418	3,778	81,343
MAX	99,834	84,478	170,309	146,978	121,472	364,316	211,834	174,989	157,325	77,060	58,974	89,926	690,394
MIN	0	0	0	0	0	0	0	0	0	0	0	0	0

*Years 1934-1989 extracted from the WAM model

*Years 1990-2000 filled in using linear regression with streamflow gage and Canyon Lake storage

Correlation Equation: $y = 0.6881x - 9690.7$ R²: 0.57
 Streamflow Gage: Guadalupe River at New Braunfels

UNAPPROPRIATED WATER IN THE MEDINA RIVER AT MEDINA LAKE (AF)
Simulated with San Antonio-Guadalupe Water Availability Model (Run 3 Modified for 2007 Pumping Rules)

YEAR	JAN	FEB	MAR	APR	MAY	JUN	JUL	AUG	SEP	OCT	NOV	DEC	TOTAL
1934	0	0	0	0	0	0	0	0	0	0	0	0	0
1935	0	0	0	0	0	0	0	0	0	0	0	0	0
1936	0	0	0	0	0	0	21221	0	111703	25146	9670	6260	174,000
1937	4433	0	0	0	0	0	0	0	0	0	0	0	4,433
1938	0	0	0	0	0	0	0	0	0	0	0	0	0
1939	0	0	0	0	0	0	0	0	0	0	0	0	0
1940	0	0	0	0	0	0	0	0	0	0	0	0	0
1941	0	0	0	0	0	0	0	0	0	0	0	0	0
1942	0	0	0	0	0	0	0	0	0	0	0	0	0
1943	0	0	0	0	0	0	0	0	0	0	0	0	0
1944	0	0	0	0	0	0	0	0	0	0	0	0	0
1945	0	0	0	0	0	0	0	0	0	0	0	0	0
1946	0	0	0	0	0	0	0	0	0	0	0	0	0
1947	0	0	0	0	0	0	0	0	0	0	0	0	0
1948	0	0	0	0	0	0	0	0	0	0	0	0	0
1949	0	0	0	0	0	0	0	0	0	0	0	0	0
1950	0	0	0	0	0	0	0	0	0	0	0	0	0
1951	0	0	0	0	0	0	0	0	0	0	0	0	0
1952	0	0	0	0	0	0	0	0	0	0	0	0	0
1953	0	0	0	0	0	0	0	0	0	0	0	0	0
1954	0	0	0	0	0	0	0	0	0	0	0	0	0
1955	0	0	0	0	0	0	0	0	0	0	0	0	0
1956	0	0	0	0	0	0	0	0	0	0	0	0	0
1957	0	0	0	0	0	0	0	0	0	0	0	0	0
1958	0	0	0	0	0	13399	0	0	5399	27866	23584	4033	74,281
1959	0	0	0	0	0	0	0	0	0	0	0	0	0
1960	0	0	0	0	0	0	0	0	0	0	0	0	0
1961	0	7944	3830	0	0	0	0	0	0	0	0	0	11,774
1962	0	0	0	0	0	0	0	0	0	0	0	0	0
1963	0	0	0	0	0	0	0	0	0	0	0	0	0
1964	0	0	0	0	0	0	0	0	0	0	0	0	0
1965	0	0	0	0	0	0	0	0	0	0	0	0	0
1966	0	0	0	0	0	0	0	0	0	0	0	0	0
1967	0	0	0	0	0	0	0	0	0	0	0	0	0
1968	0	0	0	0	0	0	0	0	0	0	0	0	0
1969	0	0	0	0	0	0	0	0	0	0	0	0	0
1970	0	0	0	0	0	0	0	0	0	0	0	0	0
1971	0	0	0	0	0	0	0	0	0	7818	13292	3171	24,281
1972	0	0	0	0	18897	0	0	0	0	0	0	0	18,897
1973	0	0	0	0	0	0	118294	7297	0	43971	9132	0	178,694
1974	0	0	0	0	0	0	0	0	0	0	0	0	0
1975	0	52138	6849	0	21952	11582	298	0	0	0	0	0	92,819
1976	0	0	0	0	0	0	0	0	0	0	0	0	0
1977	3646	8806	2115	16575	23906	1520	0	0	0	0	0	0	56,568
1978	0	0	0	0	0	0	0	51671	12760	0	0	0	64,431
1979	4313	7611	27169	26620	6698	37422	0	0	0	0	0	0	109,833
1980	0	0	0	0	0	0	0	0	0	0	0	0	0
1981	0	0	0	0	0	58194	7138	0	0	9728	0	0	75,060
1982	0	0	0	0	0	0	0	0	0	0	0	0	0
1983	0	0	0	0	0	0	0	0	0	0	0	0	0
1984	0	0	0	0	0	0	0	0	0	0	0	0	0
1985	0	0	0	0	0	0	0	0	0	0	0	0	0
1986	0	0	0	0	0	0	0	0	0	0	0	0	0
1987	13470	7831	13866	2338	50458	232443	13766	0	0	0	0	0	334,172
1988	0	0	0	0	0	0	0	0	0	0	0	0	0
1989	0	0	0	0	0	0	0	0	0	0	0	0	0
1990	0	0	0	0	0	0	0	0	0	0	0	0	0
1991	0	0	0	0	0	0	0	0	0	0	0	0	0
1992	0	0	0	27805	36794	48534	11166	3903	1303	972	2732	2809	136018
1993	2171	2059	1862	1256	6845	2425	1111	544	530	0	0	0	18803
1994	0	0	0	0	0	0	0	0	0	0	0	0	0
1995	0	0	0	0	0	0	0	0	0	0	0	0	0
1996	0	0	0	0	0	0	0	0	0	0	0	0	0
1997	0	0	0	0	0	0	0	0	0	0	684	865	1549
1998	877	0	9953	3951	425	302	126	1095	599	9183	13073	6785	46368
1999	2792	1024	759	897	822	735	502	341	159	122	236	0	8390
2000	0	0	0	0	0	0	0	0	0	0	0	0	0
AVG	473	1,305	991	1,186	2,490	6,068	2,591	968	1,977	1,863	1,081	357	21,349
MAX	13,470	52,138	27,169	27,805	50,458	232,443	118,294	51,671	111,703	43,971	23,584	6,785	334,172
MIN	0	0	0	0	0	0	0	0	0	0	0	0	0

*Years 1934-1989 extracted from the WAM model
 *Years 1990-2000 filled in using linear regression with streamflow gage and Medina Lake storage

Correlation Equation: $y = 0.5692x - 1058.6$ R²: 0.90
 Streamflow Gage: Medina River near Riomedina

UNAPPROPRIATED WATER AT THE LOWER BLANCO DIVERSION LOCATION (AF)
Simulated with San Antonio-Guadalupe Water Availability Model (Run 3 Modified for 2007 Pumping Rules)

YEAR	JAN	FEB	MAR	APR	MAY	JUN	JUL	AUG	SEP	OCT	NOV	DEC	TOTAL
1934	43	0	0	3,457	443	0	0	0	0	0	0	0	3,943
1935	0	0	0	0	26,719	44,708	2,439	0	6,574	0	1,193	2,212	83,845
1936	0	0	0	0	9,822	15,927	37,514	2,223	27,245	8,203	6,590	4,251	111,775
1937	1,084	2,767	15,535	0	0	1,806	0	0	0	4,090	0	0	25,282
1938	22,990	1,677	0	30,500	22,948	4,453	459	0	0	0	0	0	83,027
1939	0	9	9	0	0	0	0	0	0	0	0	0	18
1940	0	0	0	464	0	1,644	0	0	0	0	6,726	26,775	35,609
1941	2,665	29,147	36,136	36,263	47,502	37,748	13,071	0	0	4,172	0	2,009	208,713
1942	593	0	0	12,118	946	0	1,697	0	25,066	19,017	9,327	6	68,770
1943	0	2,776	1,755	4,541	0	0	0	0	1,924	0	182	24	11,202
1944	0	868	23,910	2,619	18,845	13,336	853	651	0	1,476	2,327	15,339	80,224
1945	21,884	23,768	32,590	18,210	4,305	2,067	0	0	0	2,120	620	4,841	110,405
1946	2,275	285	17,554	0	4,811	3,929	0	0	3,100	4,092	31,270	20,093	87,409
1947	25,615	12,687	10,088	6,268	4,093	0	0	0	0	0	0	0	58,751
1948	65	0	0	0	0	0	0	0	0	0	0	0	65
1949	0	1,581	0	17,517	0	0	0	0	0	387	0	0	19,485
1950	0	556	0	25	0	0	0	0	0	0	0	0	581
1951	0	0	0	0	0	0	0	0	0	0	0	0	0
1952	0	0	0	0	0	0	0	0	20,090	0	2,492	0	22,582
1953	0	1,172	0	985	0	0	0	0	0	0	1,985	4,043	8,185
1954	0	0	0	0	0	0	0	0	0	0	0	0	0
1955	0	0	0	0	0	0	0	0	0	0	0	0	0
1956	0	0	0	0	0	0	0	0	0	0	0	0	0
1957	0	0	0	48,438	18,626	21,095	0	0	13,485	31,231	23,457	0	156,332
1958	16,947	28,936	29,475	14,235	70,810	12,966	2,581	0	10,221	10,396	15,654	7	212,228
1959	574	4,319	0	12,319	0	2,929	140	160	1,272	21,732	1,366	5,783	50,594
1960	1,129	28	4,985	7,996	0	1,842	0	1,313	1,165	39,699	21,152	29,062	108,371
1961	25,486	54,967	20,196	7,044	1,516	22,049	6,296	985	0	1,453	0	2,500	142,492
1962	2,136	1,544	1,077	581	0	1,318	0	0	2,069	1,061	0	1,931	11,717
1963	715	0	0	299	0	0	0	0	0	0	0	0	1,014
1964	0	0	0	0	0	0	0	0	59	0	2,824	0	2,883
1965	0	23,916	7,511	7,501	46,500	33,965	2,582	0	0	0	0	22,781	144,756
1966	2,615	0	0	4,668	9,753	2,348	0	0	3,188	2,018	1,192	883	26,665
1967	0	0	0	0	0	0	0	0	2,819	0	7,335	3,396	13,550
1968	81,612	21,056	16,078	12,888	17,774	6,684	2,162	0	1,158	1,446	3,112	163,970	163,970
1969	1,843	3,706	6,050	10,266	18,206	6,262	0	0	1,195	0	2,086	6,945	56,559
1970	0	13,630	27,600	12,033	40,563	18,252	2,734	0	1,926	2,245	1,419	1,175	121,577
1971	930	0	0	0	0	0	0	0	8	575	1,937	11,907	15,357
1972	0	0	678	0	15,582	5,217	402	0	834	2,734	4,659	3,714	33,820
1973	2,994	1	13,699	15,344	0	33,015	50,047	9,557	9,419	66,525	19,351	8,997	228,949
1974	6,646	0	0	2,779	1,147	0	0	1,032	6,481	614	19,321	10,347	48,367
1975	11,116	37,518	12,337	8,388	35,607	38,222	18,055	4,946	0	5,500	3,718	2,906	178,313
1976	2,336	1,735	2,021	28,615	34,938	15,508	17,039	4,276	0	10,266	15,906	16,953	149,593
1977	14,293	16,766	11,837	54,589	20,389	6,019	1,147	0	1,174	2,853	0	1,976	131,043
1978	1,895	2,017	1,831	0	0	0	0	0	3,610	0	3,203	3,137	15,693
1979	18,057	23,698	40,989	37,701	28,008	11,263	6,189	1,955	0	1,765	1,665	1,949	173,239
1980	843	1,398	1,489	738	5,256	468	0	0	1,272	3,435	1,488	2,310	18,697
1981	2,170	2,470	9,631	4,720	50	82,356	11,709	44	2,371	21,194	8,440	0	145,155
1982	0	0	1,690	437	21,514	1,289	0	0	0	0	0	0	24,930
1983	689	0	1,668	0	7,871	6,413	1,267	0	1,625	2,658	1,971	271	24,433
1984	0	0	0	0	0	0	0	0	0	0	0	2,147	2,147
1985	0	3,114	22,399	11,690	2,860	57,553	14,847	732	622	4,948	12,593	18,993	150,351
1986	8,389	11,336	5,175	3,515	20,483	14,431	1,567	0	19,052	31,135	16,380	52,411	183,874
1987	27,810	15,041	23,090	9,914	10,477	125,830	24,561	4,701	4,308	3	14,611	4,978	265,324
1988	4,319	3,070	108	1,839	3,620	2,063	0	0	0	0	0	0	15,019
1989	0	0	0	0	2,704	827	0	0	0	0	6	17	3,554
1990	0	0	2,903	4,361	16,937	2,158	1,252	600	0	0	87	0	28,298
1991	4,856	10,191	5,457	19,516	16,406	6,250	1,690	291	6,821	2,175	768	84,278	158,698
1992	46,994	80,906	59,748	20,598	29,379	46,309	16,267	5,488	4,665	1,825	3,434	5,710	321,323
1993	9,612	11,598	10,978	8,704	6,899	6,950	4,124	1,529	1,134	2,490	1,187	1,126	66,329
1994	970	907	6,768	3,618	8,457	3,052	805	91	89	8,054	5,410	8,907	47,127
1995	11,046	3,899	4,351	7,062	15,363	20,181	3,404	1,451	612	25	445	0	67,837
1996	0	0	0	0	0	0	0	0	0	0	0	320	320
1997	0	1,154	5,207	40,354	23,837	139,410	23,647	5,361	2,289	2,038	1,379	1,866	246,542
1998	5,725	19,406	37,876	13,473	4,414	2,079	2,451	2,077	2,582	81,632	48,644	20,091	240,447
1999	6,254	2,708	2,762	2,093	1,753	1,488	713	0	0	0	0	0	17,771
2000	0	0	0	0	0	637	0	0	0	0	30,152	9,044	39,832
AVG	5,944	7,139	7,989	8,527	10,420	13,199	4,085	738	2,841	6,075	5,334	6,441	78,731
MAX	81,612	80,906	59,748	54,589	70,810	139,410	50,047	9,557	27,245	81,632	48,644	84,278	321,323
MIN	0	0	0	0	0	0	0	0	0	0	0	0	0

*Years 1934-1989 extracted from the WAM model

*Years 1990-2000 filled in using linear regression with streamflow gage

Correlation Equation: $y = 1.031x - 2160.6$

Streamflow Gage: Blanco River at Wimberley

R²: 0.90

UNAPPROPRIATED WATER AT THE CIBOLO DAM DIVERSION LOCATION (AF)
Simulated with San Antonio-Guadalupe Water Availability Model (Run 3 Modified for 2007 Pumping Rules)

YEAR	JAN	FEB	MAR	APR	MAY	JUN	JUL	AUG	SEP	OCT	NOV	DEC	TOTAL
1934	0	0	0	0	0	0	0	0	0	0	0	0	0
1935	0	0	0	0	17,760	29,368	2,785	0	1,754	1,158	0	0	52,825
1936	5	0	0	0	2,112	786	0	130	7,490	3,347	753	0	14,623
1937	0	0	2,948	0	0	6,758	0	0	0	0	0	0	9,706
1938	7,112	1,067	3,025	9,353	10,555	0	0	0	0	0	0	0	31,112
1939	0	0	0	0	0	0	0	0	0	0	0	0	0
1940	0	0	0	0	0	3,037	1,950	0	0	512	521	2,118	8,138
1941	0	6,528	7,719	13,714	14,897	13,905	3,159	0	0	0	0	67	59,989
1942	0	0	0	1,968	0	0	5,384	0	10,385	8,050	0	0	25,787
1943	0	0	0	12	0	0	1,921	0	168	0	0	0	2,101
1944	0	222	6,326	0	4,649	4,600	0	0	1,741	0	0	5,739	23,277
1945	5,548	10,793	22,881	7,297	0	430	0	0	0	2,031	0	0	48,980
1946	961	1,769	11,891	0	2,447	190	0	0	10,613	118	4,068	408	32,465
1947	14	0	0	0	0	0	0	0	0	0	0	0	14
1948	0	0	0	0	0	0	11	0	0	3	0	0	14
1949	0	0	0	2,936	125	0	0	0	0	26	0	0	3,087
1950	0	0	0	0	0	0	0	0	0	0	0	0	0
1951	0	0	0	0	0	477	0	0	0	0	0	0	477
1952	0	0	0	0	2	0	0	0	33,705	0	0	0	33,707
1953	0	0	0	0	0	0	0	0	373	0	0	0	373
1954	0	0	0	0	0	0	0	0	0	0	0	0	0
1955	0	0	0	0	2	0	0	0	0	0	0	0	2
1956	0	0	0	0	0	0	0	0	0	0	0	0	0
1957	0	0	1,697	19,773	27,021	12,861	0	0	317	4,343	0	0	66,012
1958	148	3,945	1,728	0	34,499	0	0	0	1,835	1,431	1,606	0	45,192
1959	0	0	0	0	0	0	0	0	0	40	0	0	40
1960	0	0	0	0	0	0	0	4,679	0	3,349	99	0	8,127
1961	0	0	0	0	0	0	0	0	0	89	52	0	141
1962	0	0	0	0	0	0	0	0	0	0	0	15	15
1963	0	0	0	0	0	0	0	0	0	0	0	0	0
1964	0	0	0	0	0	0	0	0	0	0	0	0	0
1965	0	21	0	3,747	40,172	5,551	0	0	0	6,667	0	7,554	63,712
1966	0	0	0	0	0	0	0	0	0	0	0	0	0
1967	0	0	0	0	0	0	0	0	651	0	6	0	657
1968	34,912	223	0	0	1,835	0	0	0	0	0	0	0	36,970
1969	0	0	0	0	910	0	0	0	0	0	0	0	910
1970	0	0	0	0	34	0	0	0	0	0	0	0	34
1971	0	0	0	0	0	0	0	7,585	0	2,462	0	0	10,047
1972	0	0	0	0	58,507	5	0	0	0	0	0	0	58,512
1973	0	0	0	17	0	4,985	98,175	847	0	28,535	1,485	0	134,044
1974	0	0	0	0	24	0	0	4,633	398	0	924	2	5,981
1975	0	9,649	0	0	1,141	2	0	0	0	0	0	0	10,792
1976	0	0	0	7,141	1,477	3	0	0	0	10,016	1,315	0	19,952
1977	0	0	0	8,456	24	0	0	0	0	0	1,835	0	10,315
1978	0	0	0	0	0	222	0	200	1,988	0	87	0	2,497
1979	217	0	13,075	2,080	49	2,110	136	2	0	0	0	0	17,669
1980	0	0	0	0	0	0	0	0	6	0	0	0	6
1981	0	0	0	0	0	10,661	0	0	0	0	578	0	11,239
1982	0	0	0	0	4,114	0	0	0	0	0	0	0	4,114
1983	0	0	0	0	0	0	0	0	0	0	0	0	0
1984	0	0	0	0	0	0	0	0	0	124	0	0	124
1985	0	0	0	0	0	32,710	4,205	0	0	0	373	0	37,288
1986	0	0	0	0	0	410	0	0	0	492	0	9,848	10,750
1987	0	46	0	0	3,334	91,890	31	0	0	0	0	0	95,301
1988	0	0	0	0	0	0	0	0	0	0	0	0	0
1989	0	0	0	0	0	0	0	0	0	0	0	0	0
1990	0	0	0	0	0	0	0	0	0	0	0	0	0
1991	5	0	0	6,510	407	1,070	0	0	0	0	0	102,436	110,428
1992	6,857	54,115	43,300	579	44,214	20,269	24	0	0	0	0	0	169,358
1993	0	0	0	0	6,226	0	0	0	0	0	0	0	6,226
1994	0	0	0	0	187	0	0	0	0	187	0	0	374
1995	0	0	0	0	0	0	0	0	0	0	0	0	0
1996	0	0	0	0	0	0	0	0	0	0	0	0	0
1997	0	0	0	0	0	135,888	2,763	95	0	0	0	0	138,747
1998	0	0	15,741	0	0	0	0	0	0	154,391	228	0	170,360
1999	0	0	0	0	0	0	0	0	0	0	0	0	0
2000	0	0	0	0	0	16	0	0	0	2,555	10,926	0	13,497
AVG	833	1,319	1,945	1,248	4,130	5,645	1,799	271	1,066	3,432	371	1,913	23,972
MAX	34,912	54,115	43,300	19,773	58,507	135,888	98,175	7,585	33,705	154,391	10,926	102,436	170,360
MIN	0	0	0	0	0	0	0	0	0	0	0	0	0

*Years 1934-1989 extracted from the WAM model

*Years 1990-2000 filled in using linear regression with streamflow gage

Correlation Equation: $y = 1.4582x - 40.81$
 Streamflow Gage: Cibolo Creek near Selma

R²: 0.96

UNAPPROPRIATED WATER AT THE SAN GERONIMO DIVERSION LOCATION (AF)
Simulated with San Antonio-Guadalupe Water Availability Model (Run 3 Modified for 2007 Pumping Rules)

YEAR	JAN	FEB	MAR	APR	MAY	JUN	JUL	AUG	SEP	OCT	NOV	DEC	TOTAL
1934	0	0	0	0	0	0	0	0	0	0	0	72	72
1935	0	0	0	0	3,270	5,664	0	0	878	556	0	0	10,368
1936	0	0	0	0	469	2,432	466	0	2,183	589	450	228	6,817
1937	0	0	0	0	0	1,945	0	0	0	0	0	0	1,945
1938	0	0	0	0	0	0	0	0	0	0	0	0	0
1939	0	0	0	0	0	0	0	0	0	0	0	0	0
1940	0	0	0	0	0	0	0	0	0	0	0	887	887
1941	0	389	1,175	2,274	2,016	1,736	0	0	0	0	0	0	7,590
1942	0	0	0	0	0	0	1,740	0	3,484	1,173	0	0	6,397
1943	0	0	0	0	0	0	0	0	0	0	0	0	0
1944	0	0	0	0	731	0	0	0	0	0	0	0	731
1945	369	1,294	2,503	1,662	0	0	0	0	0	0	0	0	5,828
1946	0	0	0	0	667	900	0	0	1,216	85	3,779	827	7,474
1947	0	0	0	0	0	0	0	0	0	0	0	0	0
1948	0	0	0	0	0	0	0	0	0	0	0	0	0
1949	0	0	0	471	0	0	0	0	0	1,337	0	0	1,808
1950	0	0	0	0	0	0	0	0	0	0	0	0	0
1951	0	0	0	0	0	0	0	0	0	0	0	0	0
1952	0	0	0	0	0	0	0	0	0	0	0	0	0
1953	0	0	0	0	0	0	0	0	0	0	0	0	0
1954	0	0	0	0	0	0	0	0	0	0	0	0	0
1955	0	0	0	0	0	0	0	0	0	0	0	0	0
1956	0	0	0	0	0	0	0	0	0	0	0	0	0
1957	0	0	0	2,307	2,649	1,933	0	0	0	0	0	0	6,889
1958	643	2,703	677	0	3,075	1,441	0	0	905	694	0	649	10,787
1959	0	0	0	0	0	0	0	0	0	0	0	0	0
1960	0	0	0	0	0	0	0	308	0	1,973	546	501	3,328
1961	0	613	0	0	0	0	961	0	0	0	0	0	1,574
1962	0	0	0	0	0	0	0	0	0	0	0	0	0
1963	0	0	0	0	0	0	0	0	0	0	0	0	0
1964	0	0	0	0	0	0	0	0	0	0	540	0	540
1965	0	0	0	0	4,477	0	0	0	0	0	0	0	4,477
1966	0	0	0	0	0	0	0	0	0	0	0	0	0
1967	0	0	0	0	0	0	0	0	0	0	101	0	101
1968	4,068	734	0	0	1,129	0	0	0	0	0	0	0	5,931
1969	0	0	0	0	609	0	0	0	0	0	0	0	609
1970	0	0	0	0	195	0	0	0	0	0	0	0	195
1971	0	0	0	0	0	0	0	1,533	0	989	324	1,087	3,933
1972	0	0	0	0	5,032	270	0	0	0	0	0	0	5,302
1973	0	0	0	1,974	0	1,200	4,515	1,195	0	3,164	0	0	12,048
1974	0	0	0	0	0	0	0	0	1,779	9	158	15	1,961
1975	0	1,026	0	0	473	103	13	0	0	0	0	0	1,615
1976	0	0	0	265	3,493	0	61	0	143	2,002	2,866	956	9,786
1977	821	1,370	473	2,324	862	385	0	0	0	0	851	0	7,086
1978	0	0	0	0	0	0	0	0	39	0	0	0	39
1979	1,094	838	3,592	2,750	1,106	4,143	168	0	0	0	0	0	13,691
1980	0	0	0	0	0	0	0	0	0	0	0	0	0
1981	0	0	0	0	0	14,175	263	0	0	487	0	0	14,925
1982	0	0	0	0	1,583	0	0	0	0	0	0	0	1,583
1983	0	0	0	0	0	0	0	0	0	0	0	0	0
1984	0	0	0	0	0	0	0	0	0	0	0	0	0
1985	0	0	806	0	0	898	0	0	0	1,875	169	0	3,748
1986	0	0	0	0	0	7,127	0	0	5	830	42	2,031	10,035
1987	0	0	0	0	1,781	6,738	568	118	4	0	0	34	9,243
1988	0	0	0	0	0	0	0	0	0	0	0	0	0
1989	0	0	0	0	0	0	0	0	0	0	0	0	0
1990	0	29	422	1,044	404	0	863	0	177	290	127	0	3,355
1991	463	415	37	5,139	1,925	22	20	0	0	0	0	7,125	15,147
1992	1,756	3,035	4,293	675	2,532	1,544	170	283	180	126	514	352	15,460
1993	235	899	613	441	26,586	749	87	0	72	123	0	52	29,856
1994	56	0	626	97	1,018	29	0	0	283	1,845	11	146	4,111
1995	1	0	0	0	181	548	9	17	793	0	0	0	1,549
1996	0	0	0	0	0	0	0	0	266	0	0	0	266
1997	0	19	0	266	131	3,701	95	0	0	71	2	418	4,703
1998	232	343	647	0	0	0	0	519	4	35,590	264	0	37,600
1999	0	0	117	0	41	84	91	0	0	0	0	0	332
2000	0	0	0	0	15	712	0	0	0	149	3,408	25	4,309
AVG	145	205	239	324	992	873	151	59	185	805	211	230	4,418
MAX	4,068	3,035	4,293	5,139	26,586	14,175	4,515	1,533	3,484	35,590	3,779	7,125	37,600
MIN	0	0	0	0	0	0	0	0	0	0	0	0	0

*Years 1934-1989 extracted from the WAM model

*Years 1990-2000 filled in using linear regression with streamflow gage

Correlation Equation: $y = 0.7517x - 36.323$ R²: 0.74
 Streamflow Gage: San Antonio River at Loop 410 (upstream)

UNAPPROPRIATED WATER AT THE LOWER VERDE DIVERSION POINT (AF)
Simulated with Nueces Water Availability Model (Run 3)

YEAR	JAN	FEB	MAR	APR	MAY	JUN	JUL	AUG	SEP	OCT	NOV	DEC	TOTAL
1934	0	0	0	0	0	0	105	0	104	0	225	0	434
1935	0	0	0	0	0	13,143	8,053	0	8,162	161	123	34	29,676
1936	0	103	0	58	192	0	66	14	0	0	0	202	635
1937	0	0	235	204	107	28	92	39	4	9	0	113	831
1938	0	148	236	170	0	0	0	43	27	0	0	18	642
1939	0	0	0	0	0	0	0	91	28	0	33	40	192
1940	0	0	0	0	0	0	62	12	1	0	4	64	143
1941	0	0	0	0	0	0	107	24	0	122	187	142	582
1942	0	0	0	0	0	69	0	37	0	82	115	13	316
1943	0	0	0	21	94	214	105	41	0	79	38	0	592
1944	0	0	0	120	75	114	0	0	79	0	23	36	447
1945	0	38	46	0	112	135	33	27	69	0	6	152	618
1946	0	0	0	52	2	12	0	236	244	0	217	27	790
1947	0	4	31	3	222	194	96	56	0	2	0	0	608
1948	0	0	0	0	0	0	0	0	41	68	0	0	109
1949	0	0	0	0	0	0	0	0	3	174	0	4	181
1950	0	0	43	232	23	110	9	8	0	4	0	0	429
1951	0	0	0	49	0	0	55	19	231	0	3	0	357
1952	0	0	56	0	38	80	38	0	194	0	68	0	474
1953	0	0	0	0	0	0	0	0	0	0	0	0	0
1954	0	0	0	0	0	0	0	0	0	0	0	0	0
1955	0	0	0	0	0	0	0	0	3	0	114	0	117
1956	0	0	0	0	0	0	0	0	0	0	67	8	75
1957	0	0	0	0	0	0	0	0	124	136	0	0	260
1958	0	0	0	0	0	0	0	0	0	0	0	0	0
1959	0	0	0	0	0	180	0	0	145	0	134	34	493
1960	0	17	93	124	92	158	3	0	0	0	0	0	487
1961	0	0	0	0	12	0	80	44	100	0	42	36	314
1962	0	0	0	0	36	25	0	0	0	0	3	33	97
1963	0	0	0	0	0	0	0	0	0	0	0	0	0
1964	0	0	0	15	0	0	0	76	30	0	107	106	334
1965	0	0	0	0	77	0	15	0	0	220	0	0	312
1966	0	0	0	145	142	9	0	232	252	71	0	0	851
1967	0	0	0	0	10	0	71	163	0	45	240	213	742
1968	0	0	0	0	0	0	189	199	107	20	10	0	525
1969	0	105	21	51	0	25	0	168	72	182	125	0	749
1970	0	124	0	140	192	28	191	0	0	0	0	1	676
1971	0	0	0	0	0	0	0	0	0	0	0	0	0
1972	0	0	2	11	0	241	0	0	0	0	29	65	348
1973	0	0	174	0	46	0	0	0	0	0	186	0	406
1974	0	0	37	14	0	116	12	0	44	22	93	66	404
1975	0	0	0	28	0	0	0	173	244	25	4	10	484
1976	0	0	0	0	0	0	0	103	211	0	0	0	314
1977	0	0	0	0	0	0	0	0	0	4	0	10	14
1978	0	0	0	0	0	44	151	0	15	74	93	0	377
1979	0	0	0	0	0	0	96	49	0	0	0	19	164
1980	0	0	0	0	0	0	0	0	0	0	0	69	69
1981	0	8	0	0	0	0	47	0	0	0	0	179	234
1982	0	0	0	0	0	0	0	0	0	0	0	0	0
1983	0	0	0	2	183	54	0	0	0	0	0	9	248
1984	0	0	24	24	0	1	0	0	23	2	20	0	94
1985	0	0	0	0	0	0	0	0	0	0	0	0	0
1986	0	107	69	0	158	0	17	0	0	237	167	0	755
1987	0	0	0	0	0	0	0	0	17	0	0	11	28
1988	0	0	0	0	0	0	0	0	0	0	0	0	0
1989	0	0	0	0	0	7	7	0	0	0	30	46	90
1990	0	0	0	0	102	0	97	0	0	134	10	0	343
1991	0	0	87	210	129	0	117	161	55	6	0	0	765
1992	0	0	0	0	0	0	0	0	76	119	72	21	288
1993	0	30	79	98	0	35	0	0	0	0	11	10	263
1994	0	0	0	0	3	78	0	104	8	54	0	10	257
1995	0	0	0	0	0	0	128	0	0	89	19	1	237
1996	0	0	0	0	0	0	2	0	0	0	0	0	2
1997	0	0	0	0	0	0	0	0	0	0	47	48	95
1998	58	78	0	0	0	0	0	0	0	285	189	109	720
1999	72	57	55	55	63	74	92	58	47	44	42	42	700
2000	42	42	41	40	41	42	41	0	0	0	0	0	288
AVG	3	13	20	28	32	227	152	32	161	37	43	30	777
MAX	72	148	236	232	222	13,143	8,053	236	8,162	285	240	213	29,676
MIN	0	0	0	0	0	0	0	0	0	0	0	0	0

*Years 1934-1996 extracted from the WAM model
 *Years 1997-2000 filled in using linear regression with streamflow gage and Choke Canyon storage

Correlation Equation: $y = 0.0187x + 40.136$
 Streamflow Gage: Hondo Creek near Tarpley

R^2: 0.22

UNAPPROPRIATED WATER AT THE LOWER HONDO DIVERSION POINT (AF)
Simulated with Nueces Water Availability Model (Run 3)

YEAR	JAN	FEB	MAR	APR	MAY	JUN	JUL	AUG	SEP	OCT	NOV	DEC	TOTAL
1934	0	3	8	90	96	0	0	0	0	0	0	0	197
1935	0	0	0	0	0	53,234	14,024	2,509	10,005	0	0	0	79,772
1936	0	199	0	177	0	0	120	47	0	0	0	0	543
1937	0	229	0	0	66	152	24	0	0	0	10	0	481
1938	0	0	0	0	0	30	23	1	0	0	0	0	54
1939	1	9	9	0	0	0	0	0	0	50	58	47	174
1940	28	49	36	134	0	0	0	24	0	0	7	117	395
1941	97	160	245	0	0	0	0	0	0	0	0	0	502
1942	158	149	125	0	0	39	51	52	0	0	257	167	998
1943	119	69	60	135	44	153	93	1	1	2	3	10	690
1944	59	104	0	0	0	0	29	0	42	66	57	130	487
1945	0	0	0	0	0	30	14	0	9	56	39	72	220
1946	55	49	28	66	77	17	0	0	88	0	0	131	511
1947	213	185	152	126	134	0	40	14	0	0	0	2	866
1948	4	11	10	0	0	0	0	0	0	3	0	0	28
1949	4	0	0	0	0	0	77	74	76	131	108	105	575
1950	113	136	123	86	82	125	22	0	0	0	0	0	687
1951	1	2	4	3	0	29	0	0	0	0	0	0	39
1952	0	0	0	0	43	52	0	0	7	0	0	40	142
1953	24	7	2	0	0	0	0	1	0	0	23	20	77
1954	21	2	0	1	0	12	0	0	0	1	0	0	37
1955	0	1	10	0	1	0	0	0	0	0	0	0	12
1956	0	0	0	0	0	0	0	0	0	1	0	0	1
1957	0	0	0	0	0	0	31	0	0	0	0	0	31
1958	0	0	0	0	0	0	0	32	0	0	0	0	32
1959	203	0	56	0	0	0	0	10	17	0	0	160	446
1960	187	169	184	210	139	10	0	0	0	0	390	0	1,289
1961	664	0	609	258	84	0	0	121	72	102	64	51	2,025
1962	27	11	7	20	6	19	0	0	0	0	1	4	95
1963	4	8	7	14	0	0	0	0	0	0	0	0	33
1964	0	0	0	0	0	0	0	2	0	83	0	42	127
1965	0	0	0	0	0	0	0	0	2	0	27	0	29
1966	163	0	88	0	0	0	27	384	0	145	54	35	896
1967	22	20	0	0	0	0	9	0	0	371	0	0	422
1968	0	0	0	0	0	0	0	139	112	72	47	90	460
1969	67	62	81	311	0	120	0	0	55	0	325	386	1,407
1970	236	0	768	338	0	0	0	0	0	0	0	0	1,342
1971	0	12	1	10	5	5	0	0	0	0	0	0	33
1972	0	0	0	99	0	470	217	0	0	0	0	48	834
1973	0	0	0	0	207	0	0	0	0	0	0	0	207
1974	0	0	0	0	0	0	37	0	0	0	0	0	37
1975	0	0	0	0	0	0	0	0	0	0	0	0	0
1976	0	0	0	0	0	0	0	0	0	0	908	954	1,862
1977	927	966	0	490	0	0	0	0	0	0	0	0	2,383
1978	0	0	0	0	12	0	0	0	0	86	0	0	98
1979	0	0	0	0	0	0	0	0	0	7	14	0	21
1980	0	9	0	11	0	3	0	12	0	249	187	283	754
1981	177	0	377	0	0	0	1,143	270	146	409	183	106	2,811
1982	67	45	30	12	0	176	29	4	1	1	11	15	391
1983	19	20	0	0	151	0	157	0	6	11	98	55	517
1984	0	33	14	0	0	0	0	0	0	0	10	0	57
1985	0	565	0	533	0	499	208	23	33	0	0	373	2,234
1986	0	135	79	52	181	0	109	96	0	0	608	0	1,260
1987	1,046	563	887	0	0	0	0	0	0	0	32	101	2,629
1988	0	0	0	0	0	0	0	0	0	9	0	0	9
1989	8	32	54	28	1	0	0	0	0	10	28	29	190
1990	19	37	0	0	0	62	0	221	132	102	68	36	677
1991	62	62	33	0	0	316	188	34	0	361	342	0	1,398
1992	0	0	0	0	0	0	0	0	33	54	0	176	263
1993	281	0	0	184	0	0	0	0	0	0	0	0	465
1994	0	0	50	0	0	0	0	3	2	0	0	0	55
1995	0	0	0	30	0	0	0	0	0	92	0	71	193
1996	0	8	9	0	0	0	0	0	0	0	0	7	24
1997	0	0	0	0	0	0	0	0	0	0	8	18	26
1998	110	289	0	0	0	0	0	0	0	2,130	1,276	563	4,368
1999	232	101	82	83	153	249	407	109	8	0	0	0	1,424
2000	0	0	0	0	0	0	0	0	0	0	0	0	0
AVG	81	67	63	52	22	833	255	62	162	69	78	66	1,811
MAX	1,046	966	887	533	207	53,234	14,024	2,509	10,005	2,130	1,276	954	79,772
MIN	0	0	0	0	0	0	0	0	0	0	0	0	0

*Years 1934-1996 extracted from the WAM model
 *Years 1997-2000 filled in using linear regression with streamflow gage and Choke Canyon storage

Correlation Equation: $y = 0.1666x - 51.525$
 Streamflow Gage: Hondo Creek near Tarpley

R^2: 0.97

UNAPPROPRIATED WATER AT THE LOWER SABINAL DIVERSION POINT (AF)
Simulated with Nueces Water Availability Model (Run 3)

YEAR	JAN	FEB	MAR	APR	MAY	JUN	JUL	AUG	SEP	OCT	NOV	DEC	TOTAL
1934	1	200	275	0	0	0	0	0	0	0	0	0	476
1935	0	0	0	39	0	96,715	22,291	2,591	18,094	0	0	0	139,730
1936	0	0	0	0	0	0	0	0	0	0	0	0	0
1937	0	0	0	0	0	0	448	102	0	190	0	0	740
1938	0	0	0	0	0	0	503	263	35	8	0	60	869
1939	0	0	318	91	0	0	0	0	304	0	0	0	713
1940	0	0	0	0	0	0	0	495	214	67	0	0	776
1941	0	0	0	0	0	0	0	0	0	0	0	0	0
1942	0	0	0	0	0	0	0	0	0	0	0	0	0
1943	0	0	0	0	424	0	0	151	47	78	77	165	942
1944	0	0	0	0	0	0	0	0	0	0	0	0	0
1945	0	0	0	0	0	0	328	65	274	0	0	0	667
1946	0	0	307	0	0	321	96	0	0	0	0	0	724
1947	0	0	0	0	0	0	0	312	115	1	7	91	526
1948	132	208	231	69	0	85	0	0	116	142	0	18	1,001
1949	142	0	0	0	0	0	0	0	0	0	0	0	142
1950	0	0	0	0	0	0	358	25	0	0	0	3	386
1951	34	44	113	123	0	0	29	0	0	0	0	0	343
1952	0	0	0	69	0	588	29	0	0	0	0	0	686
1953	0	0	0	0	0	0	0	0	0	0	0	0	0
1954	0	0	0	0	0	0	0	0	0	0	0	0	0
1955	0	0	0	0	0	0	0	0	11	0	0	0	11
1956	0	0	0	0	0	0	0	0	3	0	0	0	3
1957	0	0	0	0	0	0	0	0	0	0	0	0	0
1958	0	0	0	0	0	0	0	0	0	0	0	0	0
1959	0	0	0	14	0	0	0	0	0	0	0	0	14
1960	0	0	0	0	0	0	0	0	26	0	0	0	26
1961	0	0	0	0	0	0	0	0	0	0	0	0	0
1962	0	0	0	0	0	0	0	0	0	0	0	0	0
1963	0	0	0	0	0	0	0	0	0	0	0	0	0
1964	0	0	0	0	0	0	0	0	0	0	0	0	0
1965	0	0	0	0	0	0	0	0	0	0	0	20	20
1966	0	0	0	0	0	0	0	0	0	0	0	0	0
1967	0	0	0	0	0	0	20	0	0	0	0	0	20
1968	0	0	0	0	0	0	0	0	0	9	52	70	131
1969	40	12	0	0	0	0	0	0	0	0	0	0	52
1970	0	0	0	0	0	0	0	0	0	0	0	0	0
1971	0	0	0	0	0	0	0	0	0	0	0	0	0
1972	0	0	0	0	0	0	0	0	0	0	0	0	0
1973	0	0	0	0	0	0	0	0	0	0	0	0	0
1974	0	0	0	0	0	0	0	0	0	0	0	0	0
1975	0	0	0	0	0	0	0	0	0	0	0	0	0
1976	0	0	0	0	0	0	0	0	0	0	0	0	0
1977	0	0	0	0	0	0	0	0	0	0	0	0	0
1978	0	0	0	0	0	0	0	0	0	0	0	0	0
1979	0	0	0	0	0	0	0	0	0	0	0	0	0
1980	0	0	0	0	0	0	0	0	0	0	0	0	0
1981	0	0	0	0	0	0	0	0	0	0	0	0	0
1982	0	0	0	0	0	0	0	0	0	0	27	0	27
1983	0	0	0	0	0	0	0	0	0	0	0	0	0
1984	0	0	0	0	0	0	0	0	0	0	0	0	0
1985	0	0	0	0	0	70	0	0	0	0	0	0	70
1986	0	0	0	0	0	0	0	0	0	0	0	0	0
1987	0	0	0	0	0	0	0	0	0	0	0	0	0
1988	0	0	0	0	0	0	0	0	0	0	0	0	0
1989	0	0	0	0	0	0	0	0	20	0	0	0	20
1990	0	0	0	0	0	0	0	0	0	0	0	0	0
1991	0	0	0	0	0	0	0	0	0	0	0	0	0
1992	0	0	0	0	0	0	0	0	0	0	0	0	0
1993	0	0	0	0	0	0	0	0	0	0	0	0	0
1994	0	0	0	0	0	0	0	0	0	0	0	0	0
1995	0	0	0	0	0	0	0	0	0	0	0	0	0
1996	0	0	0	0	0	0	0	0	0	0	0	0	0
1997	0	0	0	0	0	0	0	0	0	0	0	0	0
1998	0	0	0	0	0	0	0	0	0	0	0	0	0
1999	0	0	0	0	0	0	0	0	0	0	0	0	0
2000	0	0	0	0	0	0	0	0	0	0	0	0	0
AVG	5	7	19	6	6	1,459	360	60	287	7	2	6	2,226
MAX	142	208	318	123	424	96,715	22,291	2,591	18,094	190	77	165	139,730
MIN	0	0	0	0	0	0	0	0	0	0	0	0	0

*Years 1934-1996 extracted from the WAM model

Streamflow Gage: Sabinal River near Sabinal

*Years 1997-2000 filled in with zeroes

NOTE: NOT ENOUGH DATA EXISTS ON UNAPPROPRIATED FLOWS, SINCE THE TIME CHOKE CANYON HAS BEEN IN PLACE, TO MAKE A CLEAR CORRELATION BETWEEN GAGE FLOW AND UNAPPROPRIATED WATER. HENCE WE HAVE SET UNAPPROPRIATED FLOW TO ZERO FOR THE TIME PERIOD 1997-2000.

UNAPPROPRIATED WATER AT THE LOWER FRIO DIVERSION POINT (AF)
Simulated with Nueces Water Availability Model (Run 3)

YEAR	JAN	FEB	MAR	APR	MAY	JUN	JUL	AUG	SEP	OCT	NOV	DEC	TOTAL
1934	746	0	0	0	0	0	0	0	0	0	0	0	746
1935	0	0	0	0	0	102,677	22,178	3,176	18,705	0	0	0	146,736
1936	0	0	0	0	0	0	0	0	0	0	0	0	0
1937	0	0	0	0	0	0	0	0	0	0	0	0	0
1938	0	0	0	0	0	0	0	0	0	0	0	0	0
1939	0	0	0	0	0	0	0	0	0	0	0	0	0
1940	0	0	0	0	0	0	0	0	0	0	0	0	0
1941	0	0	0	0	0	0	0	0	0	0	0	0	0
1942	0	0	0	0	0	0	69	0	0	0	0	0	69
1943	0	0	0	0	0	0	0	0	0	0	0	0	0
1944	0	0	0	0	0	0	0	0	0	0	0	0	0
1945	0	0	0	0	0	0	0	0	0	844	0	0	844
1946	0	0	0	0	0	0	0	0	0	0	0	0	0
1947	0	0	0	0	0	0	0	0	0	0	0	0	0
1948	0	0	0	0	0	0	0	0	0	33	0	0	33
1949	0	0	0	0	0	0	0	0	0	0	0	0	0
1950	0	0	0	0	0	0	0	0	0	0	0	0	0
1951	0	0	0	0	0	0	0	0	0	0	0	0	0
1952	0	0	0	0	0	0	0	0	0	0	0	0	0
1953	0	0	0	0	0	0	0	0	0	0	0	0	0
1954	0	0	0	0	0	0	0	0	0	0	0	0	0
1955	0	0	0	0	0	0	0	0	0	0	0	0	0
1956	0	0	0	0	0	0	0	0	0	0	0	0	0
1957	0	0	0	0	0	0	0	0	0	0	0	0	0
1958	0	0	0	0	0	0	0	0	0	0	0	0	0
1959	0	0	0	0	0	0	0	0	0	0	0	0	0
1960	0	0	0	0	0	0	0	0	0	0	0	0	0
1961	0	0	0	0	0	0	0	0	0	0	0	0	0
1962	0	0	0	0	0	0	0	0	0	0	0	0	0
1963	0	0	0	0	0	0	0	0	0	0	0	0	0
1964	0	0	0	0	0	0	0	0	0	1,939	0	0	1,939
1965	0	0	0	0	0	0	0	0	0	0	0	0	0
1966	0	0	0	0	0	0	0	0	0	0	0	0	0
1967	0	0	0	0	0	0	0	0	572	0	0	0	572
1968	0	0	0	0	0	0	0	0	0	0	0	0	0
1969	0	0	0	0	0	0	0	0	0	0	0	0	0
1970	0	0	0	0	0	0	0	0	0	0	0	0	0
1971	0	0	0	0	0	0	0	0	3,639	0	0	0	3,639
1972	0	0	0	0	0	0	0	0	0	0	0	0	0
1973	0	0	0	0	0	0	0	0	0	0	0	0	0
1974	0	0	0	0	0	0	0	0	0	0	0	0	0
1975	0	0	0	0	0	0	0	0	0	0	0	0	0
1976	0	0	0	0	0	0	0	0	0	0	2,248	0	2,248
1977	0	3,027	0	0	0	0	0	0	0	0	0	0	3,027
1978	0	0	0	0	0	0	0	0	0	0	0	0	0
1979	0	0	0	0	0	0	0	0	0	0	0	0	0
1980	0	0	0	0	0	0	0	0	0	0	0	0	0
1981	0	0	0	0	0	0	0	0	0	0	0	0	0
1982	0	0	0	0	0	0	0	0	0	0	0	0	0
1983	0	0	0	0	0	0	0	0	0	0	0	0	0
1984	0	0	0	0	0	0	0	0	0	654	0	0	654
1985	0	0	0	0	0	0	0	0	0	0	0	0	0
1986	0	0	0	0	0	0	0	0	0	0	0	0	0
1987	0	0	0	0	0	0	0	0	0	0	0	0	0
1988	0	0	0	0	0	0	0	0	0	0	0	0	0
1989	0	0	0	0	0	0	0	0	0	0	0	0	0
1990	0	0	0	0	0	0	0	0	0	0	0	0	0
1991	0	0	0	0	0	0	0	0	0	0	0	0	0
1992	0	0	0	0	0	0	0	0	0	0	2,118	0	2,118
1993	0	0	0	0	0	0	0	0	0	0	0	0	0
1994	0	0	0	0	0	0	0	0	0	0	0	0	0
1995	0	0	0	0	0	0	0	0	0	0	0	0	0
1996	0	0	0	0	0	0	0	0	0	0	0	0	0
1997	0	0	0	0	0	0	0	0	0	0	0	0	0
1998	0	0	0	0	0	0	0	0	0	0	0	0	0
1999	0	0	0	0	0	0	0	0	0	0	0	0	0
2000	0	0	0	0	0	0	0	0	0	0	0	0	0
AVG	11	45	0	0	0	1,532	332	47	342	52	65	0	2,427
MAX	746	3,027	0	0	0	102,677	22,178	3,176	18,705	1,939	2,248	0	146,736
MIN	0	0	0	0	0	0	0	0	0	0	0	0	0

*Years 1934-1996 extracted from the WAM model

Streamflow Gage: Frio River at Concan

*Years 1997-2000 filled in with zeroes

NOTE: NOT ENOUGH DATA EXISTS ON UNAPPROPRIATED FLOWS, SINCE THE TIME CHOKE CANYON HAS BEEN IN PLACE, TO MAKE A CLEAR CORRELATION BETWEEN GAGE FLOW AND UNAPPROPRIATED WATER. HENCE WE HAVE SET UNAPPROPRIATED FLOW TO ZERO FOR THE TIME PERIOD 1997-2000.

UNAPPROPRIATED WATER AT THE INDIAN CREEK DIVERSION POINT (AF)
Simulated with Nueces Water Availability Model (Run 3)

YEAR*	JAN	FEB	MAR	APR	MAY	JUN	JUL	AUG	SEP	OCT	NOV	DEC	TOTAL
1934	0	0	0	0	0	0	0	0	0	0	0	0	0
1935	0	0	0	0	0	630,606	0	0	3,191	0	0	0	633,797
1936	0	0	0	0	0	0	1,194	0	0	0	0	0	1,194
1937	0	0	0	0	0	0	0	0	0	0	0	0	0
1938	0	0	0	0	0	0	0	0	0	0	0	0	0
1939	0	0	0	0	0	0	0	0	0	0	0	0	0
1940	0	0	0	0	0	0	0	0	0	0	0	0	0
1941	0	0	0	0	0	0	0	0	0	0	0	0	0
1942	0	0	0	0	0	0	0	0	0	0	0	0	0
1943	0	0	0	0	0	0	0	0	0	0	0	0	0
1944	0	0	0	0	0	0	0	0	0	0	0	0	0
1945	0	0	0	0	0	0	0	0	0	0	0	0	0
1946	0	0	0	0	0	0	0	0	0	0	0	0	0
1947	0	0	0	0	0	0	0	0	0	0	0	0	0
1948	0	0	0	0	0	0	0	0	0	0	0	0	0
1949	0	0	0	0	0	0	0	0	0	0	0	0	0
1950	0	0	0	0	0	0	0	0	0	0	0	0	0
1951	0	0	0	0	0	0	0	0	0	0	0	0	0
1952	0	0	0	0	0	0	0	0	0	0	0	0	0
1953	0	0	0	0	0	0	0	0	0	0	0	0	0
1954	0	0	0	0	0	0	0	0	0	0	0	0	0
1955	0	0	0	0	0	0	0	0	0	0	0	0	0
1956	0	0	0	0	0	0	0	0	0	0	0	0	0
1957	0	0	0	0	0	0	0	0	0	0	0	0	0
1958	0	0	0	0	0	0	0	0	0	4,612	9,328	0	13,940
1959	0	0	0	0	0	0	0	0	0	0	0	0	0
1960	0	0	0	0	0	0	0	0	0	0	0	0	0
1961	0	0	0	0	0	0	0	0	0	0	0	0	0
1962	0	0	0	0	0	0	0	0	0	0	0	0	0
1963	0	0	0	0	0	0	0	0	0	0	0	0	0
1964	0	0	0	0	0	0	0	0	0	0	0	0	0
1965	0	0	0	0	0	0	0	0	0	0	0	0	0
1966	0	0	0	0	0	0	0	0	0	0	0	0	0
1967	0	0	0	0	0	0	0	0	0	0	0	0	0
1968	5,033	0	0	0	9,066	0	0	0	0	0	0	0	14,099
1969	0	0	0	0	0	0	0	0	0	0	0	0	0
1970	0	0	0	0	0	0	0	0	0	0	0	0	0
1971	0	0	0	0	0	0	0	151,572	7,024	16,676	15,754	0	191,026
1972	0	0	0	0	0	0	0	0	0	0	0	0	0
1973	0	0	0	0	0	0	0	0	0	172,385	16,503	0	188,888
1974	0	0	0	0	0	0	0	0	0	0	0	0	0
1975	0	0	0	0	0	0	0	0	0	0	0	0	0
1976	0	0	0	0	0	0	0	0	0	0	17,294	13,844	31,138
1977	0	0	0	43,627	0	0	0	0	0	0	0	0	43,627
1978	0	0	0	0	0	0	0	0	0	0	0	0	0
1979	0	0	0	0	0	0	0	0	0	0	0	0	0
1980	0	0	0	0	0	0	0	0	0	0	0	0	0
1981	0	0	0	0	0	48,155	8,005	0	0	0	0	0	56,160
1982	0	0	0	0	0	0	0	0	0	0	0	0	0
1983	0	0	0	0	0	0	0	0	0	0	0	0	0
1984	0	0	0	0	0	0	0	0	0	0	0	0	0
1985	0	0	0	0	0	0	0	0	0	0	0	0	0
1986	0	0	0	0	0	0	0	0	0	0	0	0	0
1987	0	0	0	0	0	0	29,619	0	0	0	0	0	29,619
1988	0	0	0	0	0	0	0	0	0	0	0	0	0
1989	0	0	0	0	0	0	0	0	0	0	0	0	0
1990	0	0	0	0	0	0	0	0	0	0	0	0	0
1991	0	0	0	0	0	0	0	0	0	0	0	0	0
1992	0	0	0	0	16,667	24,994	0	0	0	0	0	0	41,661
1993	0	0	0	0	0	0	0	0	0	0	0	0	0
1994	0	0	0	0	0	0	0	0	0	0	0	0	0
1995	0	0	0	0	0	0	0	0	0	0	0	0	0
1996	0	0	0	0	0	0	0	0	0	0	0	0	0
1997	0	0	0	0	0	0	0	0	0	0	0	0	0
1998	0	0	0	0	0	0	0	0	0	0	0	0	0
1999	0	0	0	0	0	0	0	0	0	0	0	0	0
2000	0	0	0	0	0	0	0	0	0	0	0	0	0
AVG	75	0	0	651	384	10,504	579	2,262	152	2,891	879	207	18,584
MAX	5,033	0	0	43,627	16,667	630,606	29,619	151,572	7,024	172,385	17,294	13,844	633,797
MIN	0	0	0	0	0	0	0	0	0	0	0	0	0

*Years 1934-1996 extracted from the WAM model

Streamflow Gage: Frio River at Concan

*Years 1997-2000 filled in with zeroes

NOTE: NOT ENOUGH DATA EXISTS ON UNAPPROPRIATED FLOWS, SINCE THE TIME CHOKE CANYON HAS BEEN IN PLACE, TO MAKE A CLEAR CORRELATION BETWEEN GAGE FLOW AND UNAPPROPRIATED WATER. HENCE WE HAVE SET UNAPPROPRIATED FLOW TO ZERO FOR THE TIME PERIOD 1997-2000.

MARKETABLE WATER IN THE GUADALUPE RIVER AT LAKE DUNLAP (AF)
Simulated with San Antonio-Guadalupe Water Availability Models (Run 8 - Run 3)

YEAR	JAN	FEB	MAR	APR	MAY	JUN	JUL	AUG	SEP	OCT	NOV	DEC	TOTAL
1934	0	0	0	0	0	0	0	0	0	0	0	0	0
1935	0	0	0	0	15279	45947	14591	0	30015	4769	0	3132	113,733
1936	301	0	0	0	21310	20882	26100	0	21536	20722	20036	13282	144,169
1937	10688	1162	14847	0	0	23957	0	0	1638	0	0	0	52,292
1938	25719	5099	0	22053	21372	0	0	0	0	0	0	0	74,243
1939	0	0	0	0	0	0	0	0	0	0	0	0	0
1940	0	0	0	0	0	0	0	0	0	0	0	22111	22,111
1941	0	46318	25927	21661	21129	21120	11328	0	0	9631	0	0	157,114
1942	0	0	0	17873	22411	0	2	0	24752	23509	7831	5911	102,289
1943	1426	0	0	0	0	0	0	0	0	0	0	0	1,426
1944	0	3768	29423	6311	27929	21745	0	0	0	0	0	18711	107,887
1945	24289	20530	20751	20810	8335	0	0	470	0	3683	0	413	99,281
1946	2961	5075	14996	275	19729	9955	0	0	10300	20150	26901	19726	130,068
1947	20632	20679	17983	7885	7310	0	0	0	0	0	0	0	74,489
1948	0	0	0	0	0	0	0	0	0	0	0	0	0
1949	0	0	0	7175	0	0	0	0	0	0	0	0	7,175
1950	0	0	0	0	0	0	0	0	0	0	0	0	0
1951	0	0	0	0	0	0	0	0	0	0	0	0	0
1952	0	0	0	0	0	0	0	0	75693	0	0	0	75,693
1953	0	0	0	0	0	0	0	0	0	0	0	0	0
1954	0	0	0	0	0	0	0	0	0	0	0	0	0
1955	0	0	0	0	0	0	0	0	0	0	0	0	0
1956	0	0	0	0	0	0	0	0	0	0	0	0	0
1957	0	0	0	2	1	0	0	0	0	30474	25692	10945	67,114
1958	34065	25561	20707	17376	25665	19236	0	0	16308	16926	20626	8652	205,122
1959	3991	3242	0	5598	0	735	0	0	0	29903	0	0	43,469
1960	4223	3557	0	0	0	0	0	14351	0	31422	20601	20652	94,806
1961	20522	20445	20903	8569	0	12292	0	0	0	0	0	0	82,731
1962	0	0	0	0	0	0	0	0	0	0	0	0	0
1963	0	0	0	0	0	0	0	0	0	0	0	0	0
1964	0	0	0	0	0	0	0	0	0	0	0	0	0
1965	0	4365	0	4130	79793	16432	0	0	0	0	0	23445	128,165
1966	0	0	0	339	3246	0	0	0	0	0	0	0	3,585
1967	0	0	0	0	0	0	0	0	5344	0	0	0	5,344
1968	28909	19136	21019	18885	18584	13781	0	0	0	0	0	0	120,314
1969	0	0	0	7824	16759	0	0	0	0	36068	0	16821	77,472
1970	8612	8750	26189	9268	15451	11259	0	0	0	0	0	0	79,529
1971	0	0	0	0	0	0	0	50653	1938	34380	16775	24723	128,469
1972	6947	7	0	0	28523	16653	0	0	0	0	0	0	52,130
1973	0	5336	13540	21292	294	12556	22651	9553	23418	32632	20860	10237	172,369
1974	19239	3038	4171	0	21692	0	0	9177	21485	3620	17807	20732	120,961
1975	20651	20516	20979	21380	26045	21583	20715	0	0	0	0	0	151,869
1976	0	0	0	11215	13084	5996	26821	0	0	9641	15518	10722	92,997
1977	18639	16199	19671	27110	21185	17997	0	0	0	0	0	0	120,801
1978	0	0	0	0	0	0	0	28957	21493	0	14670	9016	74,136
1979	17064	20603	20948	22815	25952	22132	22838	1611	0	0	0	0	153,963
1980	0	0	0	0	0	0	0	0	0	4144	0	0	4,144
1981	0	0	22023	21249	11756	33279	15557	9308	11974	27963	14964	7606	175,679
1982	5528	0	0	0	22742	512	0	0	0	0	0	0	28,782
1983	0	0	4800	0	0	2102	0	0	0	0	0	0	6,902
1984	0	0	0	0	0	0	0	0	0	0	0	0	0
1985	34190	17378	26054	14800	11932	33140	17249	0	0	24712	15795	15869	211,119
1986	13502	17192	2298	0	10902	29375	0	0	11482	28014	20866	25698	159,329
1987	20390	17836	20747	21314	24641	27016	22279	22774	0	6770	18788	17028	219,583
1988	12005	8358	8290	0	855	0	23545	0	0	0	0	0	53,053
1989	0	0	0	0	0	0	0	0	0	0	0	0	0
AVG	6,330	5,610	6,719	6,022	9,713	7,851	3,994	2,622	4,953	7,127	4,959	5,454	71,355
MAX	34,190	46,318	29,423	27,110	79,793	45,947	26,821	50,653	75,693	36,068	26,901	25,698	219,583
MIN	0	0	0	0	0	0	0	0	0	0	0	0	0

MARKETABLE WATER IN THE GUADALUPE RIVER AT COMFORT (AF)
Simulated with San Antonio-Guadalupe Water Availability Models (Run 8 - Run 3)

YEAR	JAN	FEB	MAR	APR	MAY	JUN	JUL	AUG	SEP	OCT	NOV	DEC	TOTAL
1934	0	0	0	0	0	0	0	0	0	0	0	0	0
1935	0	0	0	0	0	0	0	0	0	0	0	0	0
1936	0	0	0	0	0	0	0	0	0	0	0	0	0
1937	0	1959	0	0	0	1676	0	0	0	0	0	0	3,635
1938	0	0	0	2145	0	1176	0	0	0	0	0	0	3,321
1939	0	0	0	0	0	0	0	0	0	0	0	0	0
1940	0	0	0	0	0	0	0	0	0	0	0	21670	21,670
1941	0	0	0	41964	0	1005	1332	2073	8719	0	0	0	55,093
1942	0	0	0	21166	0	1057	0	0	19	0	25	0	22,267
1943	600	1387	0	516	0	1318	0	0	0	0	0	0	3,821
1944	73	0	0	0	0	1229	780	1240	776	496	0	0	4,594
1945	0	12607	0	2429	0	27	0	0	0	5895	1045	0	22,003
1946	0	0	1786	0	0	731	0	0	0	1738	0	0	4,255
1947	0	686	495	0	0	1108	0	0	0	0	0	0	2,289
1948	0	0	0	0	0	0	0	0	0	0	0	0	0
1949	0	0	0	4989	2770	0	0	0	0	0	0	0	7,759
1950	0	0	0	0	0	0	0	0	0	0	0	0	0
1951	0	0	0	0	0	0	0	0	0	0	0	0	0
1952	0	0	0	0	0	0	0	0	15488	0	0	2612	18,100
1953	0	0	0	0	0	0	0	0	0	0	0	0	0
1954	0	0	0	0	0	0	0	0	0	0	0	0	0
1955	0	0	0	0	0	0	0	0	0	0	0	0	0
1956	0	0	0	0	0	0	0	0	0	0	0	0	0
1957	0	0	0	0	0	0	0	0	0	37207	3	0	37,210
1958	1	26697	0	1176	0	977	1300	0	296	0	0	0	30,447
1959	0	0	0	0	750	1102	4362	0	0	61534	3605	0	71,353
1960	0	0	0	0	364	0	0	1817	2461	0	0	26143	30,785
1961	0	256	0	288	720	1128	1333	0	0	0	0	0	3,725
1962	0	0	0	0	0	0	0	0	0	0	0	0	0
1963	0	0	0	0	0	0	0	0	0	0	0	0	0
1964	0	69	0	0	0	0	0	0	0	0	0	0	69
1965	0	6813	3063	1697	4	0	818	0	0	0	0	46	12,441
1966	0	0	0	1479	5099	0	0	2227	0	1225	0	0	10,030
1967	131	0	0	0	0	0	0	0	0	0	5172	0	5,303
1968	0	0	0	0	0	78	1279	0	0	0	0	0	1,357
1969	0	92	155	0	61	0	0	0	0	0	0	0	308
1970	7328	0	0	212	0	922	1262	0	0	0	0	0	9,724
1971	0	0	0	0	0	0	0	101701	0	0	0	0	101,701
1972	0	945	510	1446	0	1096	1311	1328	0	0	0	0	6,636
1973	2048	0	2445	688	744	0	0	763	4786	0	0	7375	18,849
1974	0	1147	0	650	0	739	0	536	834	0	0	0	3,906
1975	0	0	569	0	167	1367	0	1285	5399	5918	0	0	14,705
1976	0	0	0	1583	783	0	0	836	0	0	0	0	3,202
1977	0	0	0	93	0	785	1309	0	0	0	2331	0	4,518
1978	0	0	0	0	0	0	0	0	0	0	0	0	0
1979	10843	0	150	30289	0	0	1287	0	4768	0	0	0	47,337
1980	0	0	0	0	929	0	0	0	25670	2915	0	0	29,514
1981	0	0	0	0	17537	0	1967	1329	0	86	0	0	20,919
1982	1596	0	696	663	0	827	512	0	0	0	0	0	4,294
1983	0	0	3154	324	846	1614	358	0	0	0	0	0	6,296
1984	0	0	0	0	0	0	0	0	0	0	0	0	0
1985	16221	0	0	179	32467	1063	0	0	0	0	0	0	49,930
1986	7115	0	1847	664	9865	1358	1301	0	1235	0	0	41077	64,462
1987	0	1302	0	1038	118	162329	0	676	832	513	0	0	166,808
1988	803	7688	1031	3254	0	1216	63914	1321	0	0	0	0	79,227
1989	0	0	1280	745	0	0	0	0	0	0	0	0	2,025
AVG	835	1,101	307	2,137	1,308	3,320	1,508	2,092	1,273	2,099	218	1,766	17,962
MAX	16,221	26,697	3,154	41,964	32,467	162,329	63,914	101,701	25,670	61,534	5,172	41,077	166,808
MIN	0	0	0	0	0	0	0	0	0	0	0	0	0

MARKETABLE WATER IN THE GUADALUPE RIVER AT CANYON LAKE (AF)
Simulated with San Antonio-Guadalupe Water Availability Models (Run 8 - Run 3)

YEAR	JAN	FEB	MAR	APR	MAY	JUN	JUL	AUG	SEP	OCT	NOV	DEC	TOTAL
1934	0	0	0	0	0	0	0	0	0	0	0	0	0
1935	0	0	0	0	9196	45908	14624	0	30084	4780	0	3139	107,731
1936	302	0	0	0	21359	20931	7112	0	21586	20769	20082	13313	125,454
1937	10712	1164	14881	0	0	22344	0	0	0	0	0	0	49,101
1938	25529	5111	0	22103	20110	0	0	0	0	0	0	0	72,853
1939	0	0	0	0	0	0	0	0	0	0	0	0	0
1940	0	0	0	0	0	0	0	0	0	0	0	22161	22,161
1941	0	46424	25987	21695	11820	21169	11355	0	0	9653	0	0	148,103
1942	0	0	0	17914	22462	0	3	0	14962	16154	7849	5925	85,269
1943	1430	0	0	0	0	0	0	0	0	0	0	0	1,430
1944	0	3776	23745	6325	19885	21794	0	0	0	0	0	18755	94,280
1945	23417	18964	20799	11348	4101	0	0	0	0	3691	0	414	82,734
1946	2968	5086	15030	276	18576	6122	0	0	6711	17186	23366	19771	115,092
1947	18026	19026	18024	7904	7327	0	0	0	0	0	0	0	70,307
1948	0	0	0	0	0	0	0	0	0	0	0	0	0
1949	0	0	0	7191	0	0	0	0	0	0	0	0	7,191
1950	0	0	0	0	0	0	0	0	0	0	0	0	0
1951	0	0	0	0	0	0	0	0	0	0	0	0	0
1952	0	0	0	0	0	0	0	0	67441	0	0	0	67,441
1953	0	0	0	0	0	0	0	0	0	0	0	0	0
1954	0	0	0	0	0	0	0	0	0	0	0	0	0
1955	0	0	0	0	0	0	0	0	0	0	0	0	0
1956	0	0	0	0	0	0	0	0	0	0	0	0	0
1957	0	0	0	0	0	0	0	0	0	30545	25751	10970	67,266
1958	34144	25619	20755	17416	18749	19281	0	0	16346	16965	20674	8672	198,621
1959	4000	3249	0	5611	0	736	0	0	0	29972	0	0	43,568
1960	4232	3565	0	0	0	0	0	14384	0	17860	14525	20700	75,266
1961	9395	20492	15823	8589	0	12320	0	0	0	0	0	0	66,619
1962	0	0	0	0	0	0	0	0	0	0	0	0	0
1963	0	0	0	0	0	0	0	0	0	0	0	0	0
1964	0	0	0	0	0	0	0	0	0	0	0	0	0
1965	0	1776	0	4140	65576	16471	0	0	0	0	0	19880	107,843
1966	0	0	0	339	3253	0	0	0	0	0	0	0	3,592
1967	0	0	0	0	0	0	0	0	0	0	0	0	0
1968	12378	19180	21068	18929	18627	13813	0	0	0	0	0	0	103,995
1969	0	0	0	7842	15244	0	0	0	0	36150	0	16860	76,096
1970	8632	8770	26250	9289	13893	11285	0	0	0	0	0	0	78,119
1971	0	0	0	0	0	0	0	50770	1942	34460	16813	24780	128,765
1972	6963	7	0	0	2877	16691	0	0	0	0	0	0	26,538
1973	0	5348	13572	18274	295	12584	22703	9575	23269	27915	20908	10260	164,703
1974	12732	3045	4181	0	21741	0	0	9199	21535	3628	17848	20780	114,689
1975	20699	20562	16384	21429	8835	21633	20763	0	0	0	0	0	130,305
1976	0	0	0	11242	5374	6010	26883	0	0	5251	15554	10747	81,061
1977	18682	16236	17442	13778	21012	18038	0	0	0	0	0	0	105,188
1978	0	0	0	0	0	0	0	29023	21542	0	14703	9037	74,305
1979	16327	20649	18468	20345	18518	22183	22891	1614	0	0	0	0	140,995
1980	0	0	0	0	0	0	0	0	0	4154	0	0	4,154
1981	0	0	22073	21298	11783	21639	15593	9330	8779	28027	14998	7623	161,143
1982	5541	0	0	0	21875	514	0	0	0	0	0	0	27,930
1983	0	0	4811	0	0	2107	0	0	0	0	0	0	6,918
1984	0	0	0	0	0	0	0	0	0	0	0	0	0
1985	34269	17418	26114	14835	11959	33217	17289	0	0	24768	15831	15905	211,605
1986	13533	17232	2303	0	10927	29444	0	0	11509	28079	20914	18286	152,227
1987	20437	16695	20795	21363	22945	2742	22330	21977	0	6786	15198	13260	184,528
1988	8936	6248	3751	0	857	0	23599	0	0	0	0	0	43,391
1989	0	0	0	0	0	0	0	0	0	0	0	0	0
AVG	5,594	5,458	6,290	5,526	7,664	7,125	3,663	2,605	4,388	6,550	4,732	5,201	64,796
MAX	34,269	46,424	26,250	22,103	65,576	45,908	26,883	50,770	67,441	36,150	25,751	24,780	211,605
MIN	0	0	0	0	0	0	0	0	0	0	0	0	0

MARKETABLE WATER IN THE MEDINA RIVER AT MEDINA LAKE (AF)
Simulated with San Antonio-Guadalupe Water Availability Models (Run 8 - Run 3)

YEAR	JAN	FEB	MAR	APR	MAY	JUN	JUL	AUG	SEP	OCT	NOV	DEC	TOTAL
1934	0	0	0	0	0	0	0	0	0	0	0	0	0
1935	0	0	0	0	0	0	0	0	0	0	0	0	0
1936	0	0	0	0	0	8807	0	0	172	0	0	0	8,979
1937	0	0	0	0	0	0	0	0	0	0	0	0	0
1938	0	0	0	0	0	0	0	0	0	0	0	0	0
1939	0	0	0	0	0	0	0	0	0	0	0	0	0
1940	0	0	0	0	0	0	0	0	0	0	0	0	0
1941	0	0	0	0	0	0	0	0	0	0	0	0	0
1942	0	0	0	0	0	0	0	0	0	0	0	0	0
1943	0	0	0	0	0	0	0	0	0	0	0	0	0
1944	0	0	0	0	0	0	0	0	0	0	0	0	0
1945	0	0	0	0	0	0	0	0	0	0	0	0	0
1946	0	0	0	0	0	0	0	0	0	0	0	0	0
1947	0	0	0	0	0	0	0	0	0	0	0	0	0
1948	0	0	0	0	0	0	0	0	0	0	0	0	0
1949	0	0	0	0	0	0	0	0	0	0	0	0	0
1950	0	0	0	0	0	0	0	0	0	0	0	0	0
1951	0	0	0	0	0	0	0	0	0	0	0	0	0
1952	0	0	0	0	0	0	0	0	0	0	0	0	0
1953	0	0	0	0	0	0	0	0	0	0	0	0	0
1954	0	0	0	0	0	0	0	0	0	0	0	0	0
1955	0	0	0	0	0	0	0	0	0	0	0	0	0
1956	0	0	0	0	0	0	0	0	0	0	0	0	0
1957	0	0	0	0	0	0	0	0	0	0	0	0	0
1958	0	0	0	0	10198	0	0	0	0	0	0	0	10,198
1959	0	0	0	0	0	0	0	0	0	0	0	0	0
1960	0	0	0	0	0	0	0	0	0	0	0	0	0
1961	0	18192	0	0	0	0	0	0	0	0	0	0	18,192
1962	0	0	0	0	0	0	0	0	0	0	0	0	0
1963	0	0	0	0	0	0	0	0	0	0	0	0	0
1964	0	0	0	0	0	0	0	0	0	0	0	0	0
1965	0	0	0	0	0	0	0	0	0	0	0	0	0
1966	0	0	0	0	0	0	0	0	0	0	0	0	0
1967	0	0	0	0	0	0	0	0	0	0	0	0	0
1968	0	0	0	0	0	0	0	0	0	0	0	0	0
1969	0	0	0	0	0	0	0	0	0	0	0	0	0
1970	0	0	0	0	0	0	0	0	0	0	0	0	0
1971	0	0	0	0	0	0	0	0	0	22705	0	0	22,705
1972	0	0	0	0	0	0	0	0	0	0	0	0	0
1973	0	0	0	0	0	0	68915	0	0	0	0	0	68,915
1974	0	0	0	0	0	0	0	0	0	0	0	0	0
1975	0	28804	0	0	0	0	0	0	0	0	0	0	28,804
1976	0	0	0	0	0	0	0	0	0	0	0	0	0
1977	0	0	0	16495	0	0	0	0	0	0	0	0	16,495
1978	0	0	0	0	0	0	0	8364	0	0	0	0	8,364
1979	0	0	0	0	318	0	0	0	0	0	0	0	318
1980	0	0	0	0	0	0	0	0	0	0	0	0	0
1981	0	0	0	0	0	33096	0	0	0	0	0	0	33,096
1982	0	0	0	0	0	0	0	0	0	0	0	0	0
1983	0	0	0	0	0	0	0	0	0	0	0	0	0
1984	0	0	0	0	0	0	0	0	0	0	0	0	0
1985	0	0	0	0	0	0	0	0	0	0	0	0	0
1986	0	0	0	0	0	0	0	0	0	0	0	9397	9,397
1987	0	0	0	0	0	100647	0	0	0	0	0	0	100,647
1988	0	0	0	0	0	0	0	0	0	0	0	0	0
1989	0	0	0	0	0	0	0	0	0	0	0	0	0
AVG	0	839	0	295	188	2,546	1,231	149	3	405	0	168	5,823
MAX	0	28,804	0	16,495	10,198	100,647	68,915	8,364	172	22,705	0	9,397	100,647
MIN	0	0	0	0	0	0	0	0	0	0	0	0	0

MARKETABLE WATER IN THE COMAL RIVER DOWNSTREAM OF COMAL SPRINGS (AF)
Simulated with San Antonio-Guadalupe Water Availability Models (Run 8 - Run 3)

YEAR	JAN	FEB	MAR	APR	MAY	JUN	JUL	AUG	SEP	OCT	NOV	DEC	TOTAL
1934	0	0	0	0	0	0	0	0	0	0	0	0	0
1935	0	0	0	0	15288	9	14092	0	9795	4772	0	3134	47,090
1936	301	0	0	0	15843	16520	1	0	0	0	14388	13290	60,343
1937	10694	1162	14856	0	0	19510	0	0	1639	0	0	0	47,861
1938	14640	5102	0	18275	16348	0	0	0	0	0	0	0	54,365
1939	0	0	0	0	0	0	0	0	0	0	0	0	0
1940	0	0	0	0	0	0	0	0	0	0	0	14270	14,270
1941	0	11646	9	0	0	8632	11335	0	0	9637	0	0	41,259
1942	0	0	0	13751	13082	0	2	0	19485	7258	7836	5915	67,329
1943	1427	0	0	0	0	0	0	0	0	0	0	0	1,427
1944	0	3770	12317	6314	11	8697	0	0	0	0	0	14311	45,420
1945	1	0	1	0	8340	0	0	470	0	3685	0	413	12,910
1946	2963	5078	15005	275	18098	9961	0	0	10306	15323	10	6636	83,655
1947	0	10141	15577	7890	7314	0	0	0	0	0	0	0	40,922
1948	0	0	0	0	0	0	0	0	0	0	0	0	0
1949	0	0	0	7179	0	0	0	0	0	0	0	0	7,179
1950	0	0	0	0	0	0	0	0	0	0	0	0	0
1951	0	0	0	0	0	0	0	0	0	0	0	0	0
1952	0	0	0	0	0	0	0	0	29415	0	0	0	29,415
1953	0	0	0	0	0	0	0	0	0	0	0	0	0
1954	0	0	0	0	0	0	0	0	0	0	0	0	0
1955	0	0	0	0	0	0	0	0	0	0	0	0	0
1956	0	0	0	0	0	0	0	0	0	0	0	0	0
1957	0	0	0	2	1	0	0	0	0	7706	7437	8828	23,974
1958	10895	17	0	11883	0	10818	0	0	14360	14586	15166	8658	86,383
1959	3993	3244	0	5602	0	735	0	0	0	0	0	0	13,574
1960	4225	3559	0	0	0	0	0	9691	0	1	0	0	17,476
1961	0	0	3598	8575	0	12299	0	0	0	0	0	0	24,472
1962	0	0	0	0	0	0	0	0	0	0	0	0	0
1963	0	0	0	0	0	0	0	0	0	0	0	0	0
1964	0	0	0	0	0	0	0	0	0	0	0	0	0
1965	0	4368	0	4133	12	1	0	0	0	0	0	14362	22,876
1966	0	0	0	339	3248	0	0	0	0	0	0	0	3,587
1967	0	0	0	0	0	0	0	0	5348	0	0	0	5,348
1968	14	0	5635	5291	0	8589	0	0	0	0	0	0	19,529
1969	0	0	0	7829	11007	0	0	0	0	7999	0	12210	39,045
1970	8617	8755	1318	9273	11	9933	0	0	0	0	0	0	37,907
1971	0	0	0	0	0	0	0	6130	1939	5742	11876	11620	37,307
1972	6951	7	0	0	0	11872	0	0	0	0	0	0	18,830
1973	0	5339	13549	15290	294	12	1	9559	21236	13	13410	10243	88,946
1974	19251	3039	4173	0	7694	0	0	9183	12876	3622	15	15772	75,625
1975	17043	0	6295	15939	0	1	7072	0	0	0	0	0	46,350
1976	0	0	0	3825	0	6000	11841	0	0	2622	7297	668	32,253
1977	9520	6148	18906	1	0	13799	0	0	0	0	0	0	48,374
1978	0	0	0	0	0	0	0	0	0	0	14678	9022	23,700
1979	12	0	0	0	0	0	14408	1612	0	0	0	0	16,032
1980	0	0	0	0	0	0	0	0	0	4147	0	0	4,147
1981	0	0	8924	7112	11763	10	13152	9314	11981	16	14973	7610	84,855
1982	5531	0	0	0	7838	513	0	0	0	0	0	0	13,882
1983	0	0	4803	0	0	2103	0	0	0	0	0	0	6,906
1984	0	0	0	0	0	0	0	0	0	0	0	0	0
1985	10758	11094	2898	12275	11118	11	16430	0	0	0	15804	14663	95,051
1986	13510	14782	2299	0	10909	14535	0	0	11215	10	8432	0	75,692
1987	0	0	0	19427	1	1	0	10484	0	6774	18800	17039	72,526
1988	12012	8363	8295	0	856	0	12974	0	0	0	0	0	42,500
1989	0	0	0	0	0	0	0	0	0	0	0	0	0
AVG	2,721	1,886	2,472	3,223	2,841	2,760	1,809	1,008	2,671	1,677	2,681	3,369	29,118
MAX	19,251	14,782	18,906	19,427	18,098	19,510	16,430	10,484	29,415	15,323	18,800	17,039	95,051
MIN	0	0	0	0	0	0	0	0	0	0	0	0	0

MARKETABLE WATER AT THE LOWER BLANCO DIVERSION LOCATION (AF)
Simulated with San Antonio-Guadalupe Water Availability Model (Runs 3 & 8 Modified for 2007 Pumping Rules)

YEAR	JAN	FEB	MAR	APR	MAY	JUN	JUL	AUG	SEP	OCT	NOV	DEC	TOTAL
1934	2,347	3,217	6,663	11,223	67	0	0	0	0	0	558	629	24,704
1935	29	1,821	0	1	123	119	122	0	79	2,387	36	34	4,751
1936	2,171	274	212	0	92	108	116	112	76	35	24	22	3,242
1937	7,874	4,363	41	7,102	309	102	0	0	0	294	0	0	20,085
1938	64	10,769	8,292	61	74	105	118	0	0	0	0	0	19,483
1939	0	25	36	0	0	0	0	0	0	0	21	14	96
1940	13	0	0	542	0	995	0	0	0	0	28	41	1,619
1941	4,288	34	40	54	75	108	132	0	1,704	2,107	1,595	32	10,169
1942	25	297	0	74	75	0	131	0	107	40	26	5,634	6,409
1943	4,681	30	1,694	64	0	0	0	64	68	326	27	22	6,976
1944	4,743	13,202	52	8,882	75	109	117	2,332	9,401	44	30	32	39,019
1945	34	26	41	54	74	104	0	0	0	782	33	28	1,176
1946	3,239	8,921	41	8,041	82	103	0	0	80	44	50	24	20,625
1947	23	26	40	54	75	0	0	0	0	0	16	0	234
1948	0	0	2	0	177	7	0	0	0	0	0	8	194
1949	0	26	0	53	6,679	0	0	40	5	215	0	0	7,018
1950	22	24	5	1,800	0	0	0	0	0	0	0	0	1,851
1951	0	0	16	0	0	666	0	0	0	0	0	0	682
1952	0	0	0	0	329	0	0	0	66,379	332	25	4,020	71,085
1953	6,603	345	0	2,090	0	0	0	0	10,542	3,375	426	22	23,403
1954	290	0	0	0	0	0	0	0	0	0	0	0	290
1955	0	0	0	0	373	0	0	0	0	0	0	0	373
1956	0	0	0	0	0	0	0	0	0	0	0	0	0
1957	0	0	0	93	74	108	0	0	145	67	26	15,874	16,387
1958	28	26	41	54	75	108	126	0	91	43	26	7,198	7,816
1959	4,431	691	6,035	61	4,850	0	118	110	99	67	3,316	21	19,799
1960	9,404	12,884	4,658	54	2,825	104	1,316	126	306	67	24	22	31,790
1961	32	26	40	54	69	114	132	110	2,814	1,019	2,861	30	7,301
1962	40	29	165	547	0	2,468	0	0	125	41	0	309	3,724
1963	303	1,772	0	553	0	0	0	0	0	0	23	23	2,674
1964	0	0	0	0	0	0	0	0	85	0	31	0	116
1965	3,335	37	57	7,075	76	108	118	110	1,767	7,421	5,244	45	25,393
1966	8,100	10,541	11,189	6,897	1,121	99	0	0	75	36	27	25	38,110
1967	299	0	0	0	0	0	0	0	362	2,788	944	25	4,418
1968	94	26	41	54	74	109	118	0	1,839	54	25	23	2,457
1969	30	36	51	62	75	108	85	0	74	2,363	31	45	2,960
1970	6,861	28	41	54	75	109	117	0	76	36	25	20	7,442
1971	29	0	0	0	0	0	0	0	0	457	2,471	22	2,979
1972	5,436	3,135	473	0	127	114	118	0	73	40	37	31	9,584
1973	4,362	11,486	40	54	9,408	116	132	123	68	38	23	20	25,870
1974	31	5,522	4,521	828	76	0	0	119	72	6,132	44	24	17,369
1975	24	26	41	54	74	109	132	121	4,088	54	25	24	4,772
1976	36	29	47	54	75	108	132	121	4,108	36	23	22	4,791
1977	34	26	41	54	75	108	117	0	500	34	2,825	22	3,836
1978	35	30	43	859	0	0	49	0	284	1,264	42	31	2,637
1979	84	30	41	54	75	108	132	111	2,799	48	24	24	3,530
1980	1,139	30	43	539	95	97	0	0	475	43	32	28	2,521
1981	20	27	69	68	79	99	131	1,711	68	58	26	4,878	7,234
1982	3,688	2,713	807	541	79	101	0	0	0	0	0	306	8,235
1983	42	1,987	5,196	6,462	103	116	121	0	74	41	26	305	14,473
1984	242	164	0	0	0	0	0	0	0	0	0	316	722
1985	17,589	10,557	41	54	75	109	132	110	978	31	45	21	29,742
1986	33	26	727	59	78	108	118	0	2,794	36	24	24	4,027
1987	33	26	40	54	74	93	131	110	56	2,367	32	33	3,049
1988	33	29	2,850	61	0	104	0	0	215	0	0	0	3,292
1989	248	0	0	0	5,966	630	0	0	0	0	36	24	6,904
AVG	1,831	1,881	973	1,169	615	144	77	99	2,017	619	379	721	10,526
MAX	17,589	13,202	11,189	11,223	9,408	2,468	1,316	2,332	66,379	7,421	5,244	15,874	71,085
MIN	0	0	0	0	0	0	0	0	0	0	0	0	0

MARKETABLE WATER AT THE CIBOLO DAM DIVERSION LOCATION (AF)
 Simulated with San Antonio-Guadalupe Water Availability Model (Runs 3 & 8 Modified for 2007 Pumping Rules)

YEAR	JAN	FEB	MAR	APR	MAY	JUN	JUL	AUG	SEP	OCT	NOV	DEC	TOTAL
1934	0	0	0	0	0	0	0	0	0	0	0	0	0
1935	0	0	0	0	0	0	0	0	0	0	0	0	0
1936	0	0	0	0	0	523	0	211	122	0	0	0	856
1937	0	0	0	434	0	0	0	0	0	0	0	0	434
1938	0	0	0	0	0	0	0	0	0	0	0	0	0
1939	0	0	0	0	0	0	0	0	0	0	0	0	0
1940	0	0	0	0	0	0	0	0	0	0	0	0	0
1941	0	0	0	0	0	0	0	0	0	0	0	0	0
1942	0	65	0	0	0	0	0	0	0	0	0	0	65
1943	0	0	0	0	0	0	0	0	0	52	0	0	52
1944	0	0	0	292	0	0	0	0	0	0	23	0	315
1945	0	0	0	0	0	0	0	0	0	0	0	0	0
1946	0	0	0	0	0	0	0	0	0	0	0	0	0
1947	0	0	0	0	0	0	0	0	0	0	0	0	0
1948	0	0	0	0	0	0	0	0	0	0	0	0	0
1949	0	0	0	0	0	0	0	0	0	0	0	0	0
1950	0	0	0	0	0	0	0	0	0	0	0	0	0
1951	0	0	0	0	0	0	0	0	0	0	0	0	0
1952	0	0	0	0	0	0	0	0	0	0	0	0	0
1953	0	0	0	2	0	0	0	0	0	0	0	0	2
1954	0	0	0	0	0	0	0	0	0	0	0	0	0
1955	0	0	0	0	0	0	0	0	0	0	0	0	0
1956	0	0	0	0	0	0	0	0	0	0	0	0	0
1957	0	0	0	0	0	0	0	0	0	0	0	0	0
1958	0	0	0	0	0	0	0	0	0	0	0	0	0
1959	0	0	0	0	0	159	0	0	0	0	0	0	159
1960	0	0	0	0	0	0	0	0	0	0	0	0	0
1961	0	0	0	0	0	0	0	0	0	0	0	0	0
1962	0	0	0	0	0	0	0	0	0	0	0	0	0
1963	0	0	0	0	0	0	0	0	0	0	0	0	0
1964	0	0	0	0	0	4,603	0	0	0	0	0	0	4,603
1965	0	0	0	0	0	0	0	0	0	0	0	0	0
1966	0	0	0	0	0	0	0	0	0	0	0	0	0
1967	0	0	0	0	0	0	0	0	0	0	0	0	0
1968	0	0	0	0	0	0	0	0	0	0	0	0	0
1969	0	0	0	0	0	0	0	0	0	0	0	0	0
1970	0	0	0	0	0	0	0	0	0	0	0	0	0
1971	0	0	0	0	0	0	0	0	0	0	0	0	0
1972	0	0	0	0	0	0	0	0	0	0	0	0	0
1973	0	0	0	0	0	0	0	0	7,131	0	0	0	7,131
1974	0	0	0	0	0	0	0	0	0	0	0	0	0
1975	0	0	0	0	0	0	0	0	0	0	0	0	0
1976	0	0	0	0	0	0	0	0	0	0	0	0	0
1977	0	0	0	0	0	0	0	0	0	0	0	0	0
1978	0	0	0	0	0	0	0	0	0	0	0	0	0
1979	0	0	0	0	0	0	0	0	0	0	0	0	0
1980	0	0	0	0	0	0	0	0	0	0	0	0	0
1981	0	0	0	0	0	541	0	0	0	0	0	0	541
1982	0	0	0	0	0	0	0	0	0	0	0	0	0
1983	0	0	0	0	0	0	0	0	0	0	0	0	0
1984	0	0	0	0	0	0	0	0	0	0	0	0	0
1985	0	0	0	0	0	0	0	0	0	0	0	0	0
1986	0	0	0	0	0	0	0	0	0	0	0	0	0
1987	0	0	0	0	0	0	0	0	0	0	0	0	0
1988	0	0	0	0	0	0	0	0	0	0	0	0	0
1989	0	0	0	0	0	0	0	0	0	0	0	0	0
AVG	0	1	0	13	0	104	0	4	130	1	0	0	253
MAX	0	65	0	434	0	4,603	0	211	7,131	52	23	0	7,131
MIN	0	0	0	0	0	0	0	0	0	0	0	0	0

MARKETABLE WATER AT THE SAN GERONIMO DIVERSION LOCATION (AF)
Simulated with San Antonio-Guadalupe Water Availability Model (Runs 3 & 8 Modified for 2007 Pumping Rules)

YEAR	JAN	FEB	MAR	APR	MAY	JUN	JUL	AUG	SEP	OCT	NOV	DEC	TOTAL
1934	0	0	0	3	180	0	30	0	40	0	173	4	430
1935	0	0	0	0	4	1	1	0	3	0	1	1	11
1936	0	0	0	0	3	2	2	420	1	0	1	1	430
1937	0	0	0	138	0	1	1	0	627	0	120	115	1,002
1938	0	10	0	0	1	255	153	0	45	175	85	116	840
1939	0	0	0	0	0	0	0	0	0	0	0	0	0
1940	0	0	0	0	0	145	157	0	0	0	278	1	581
1941	0	1	1	1	2	2	0	0	0	3	0	0	10
1942	0	0	0	3	1	0	2	0	1	1	1	0	9
1943	0	0	0	0	0	0	0	0	108	0	11	0	119
1944	0	0	31	107	1	1	0	222	307	235	0	0	904
1945	0	0	1	1	230	1	0	0	0	0	0	55	288
1946	0	0	342	1	45	1	0	155	4	0	1	1	550
1947	0	0	2	1	0	3	0	0	0	0	0	2	8
1948	0	0	0	0	0	0	0	0	0	0	0	0	0
1949	0	0	0	6	0	801	0	0	0	4	0	1	812
1950	0	0	0	0	0	595	0	0	0	0	0	0	595
1951	0	0	0	0	0	0	0	0	0	0	0	0	0
1952	0	0	0	0	0	0	0	0	0	0	0	0	0
1953	0	0	0	0	0	0	0	0	0	0	0	0	0
1954	0	0	0	0	0	0	0	0	0	0	0	0	0
1955	0	0	0	0	0	0	0	0	0	0	0	0	0
1956	0	0	0	0	0	0	0	0	0	0	0	0	0
1957	0	0	0	16	1	2	0	0	0	0	0	1	20
1958	0	0	0	1	1	1	2	0	3	1	0	1	10
1959	0	0	0	2	0	0	0	0	0	2	0	0	4
1960	0	0	141	0	0	0	0	5	0	218	0	0	364
1961	0	0	0	0	0	4	2	0	0	0	0	0	6
1962	0	0	0	0	0	0	0	0	0	0	0	0	0
1963	0	0	0	0	0	0	0	0	0	0	0	0	0
1964	0	0	0	0	0	0	0	0	3	1,137	1	0	1,141
1965	0	0	0	1	1	1	0	0	0	0	0	17	20
1966	0	0	0	0	0	0	0	88	0	0	0	0	88
1967	0	0	0	0	0	0	0	0	885	1	0	0	886
1968	0	0	1	1	1	1	0	0	0	0	0	0	4
1969	0	0	0	0	7	0	0	0	0	0	0	510	517
1970	0	0	0	0	3	1	0	0	0	0	0	0	4
1971	0	0	0	0	0	0	0	3	0	2	1	1	7
1972	0	0	0	0	3	2	0	0	0	0	0	0	5
1973	0	0	1	1	173	2	1	1	6,041	1	0	0	6,221
1974	0	0	0	0	0	0	0	0	9	0	1	1	11
1975	0	1	0	0	2	2	0	0	1	6	0	0	12
1976	0	0	0	5	1	2	1	0	2	1	0	0	12
1977	0	0	1	1	1	1	0	0	0	0	3	0	7
1978	0	0	0	0	0	0	0	0	6	0	1	0	7
1979	1	0	1	1	1	2	2	1	0	0	0	0	9
1980	0	0	0	0	0	0	0	0	0	0	0	0	0
1981	0	0	0	0	0	7	1	1	0	3	0	0	12
1982	0	0	0	0	4	0	0	0	0	0	0	0	4
1983	0	0	0	0	0	0	0	0	0	0	0	0	0
1984	0	0	0	0	0	0	0	0	0	0	0	0	0
1985	0	333	0	1	0	2	0	0	0	3	0	57	396
1986	0	0	0	0	0	5	0	0	0	4	1	0	10
1987	0	0	0	0	3	2	2	0	0	0	0	0	7
1988	0	0	0	0	0	0	0	0	0	0	0	0	0
1989	0	0	0	0	0	0	0	0	0	0	0	0	0
AVG	0	6	9	5	12	33	6	16	144	32	12	16	292
MAX	1	333	342	138	230	801	157	420	6,041	1,137	278	510	6,221
MIN	0	0	0	0	0	0	0	0	0	0	0	0	0

MARKETABLE WATER AT THE LOWER VERDE DIVERSION LOCATION (AF)
Simulated with Nueces Water Availability Model (Runs 3 & 8)

YEAR	JAN	FEB	MAR	APR	MAY	JUN	JUL	AUG	SEP	OCT	NOV	DEC	TOTAL
1934	0	0	0	0	0	0	0	0	0	0	0	0	0
1935	0	0	0	0	0	0	0	0	0	0	0	0	0
1936	0	0	0	0	0	0	0	0	885	1,801	1,634	0	4,320
1937	0	0	0	0	0	0	0	0	0	0	0	0	0
1938	0	0	0	0	1,142	0	0	0	0	0	0	0	1,142
1939	0	0	0	0	0	0	0	0	0	0	0	0	0
1940	0	0	0	0	867	108	0	0	0	0	0	0	975
1941	0	0	0	0	0	4,361	0	0	1,926	0	0	0	6,287
1942	0	0	0	0	0	0	0	0	345	0	0	0	345
1943	0	0	0	0	0	0	0	0	0	0	0	0	0
1944	0	0	0	0	0	0	0	0	0	0	0	0	0
1945	0	0	0	5,445	0	0	0	0	0	0	0	0	5,445
1946	0	0	0	0	0	0	0	0	0	868	0	0	868
1947	0	0	0	0	0	0	0	0	0	0	0	0	0
1948	0	0	0	0	0	0	0	0	0	0	0	0	0
1949	0	0	0	0	951	0	0	0	0	0	0	0	951
1950	0	0	0	0	0	0	0	0	0	0	0	0	0
1951	0	0	0	0	0	0	0	0	0	0	0	0	0
1952	0	0	0	0	0	0	0	0	0	0	0	0	0
1953	0	0	0	0	0	0	0	0	0	0	0	0	0
1954	0	0	0	0	0	0	0	0	0	0	0	0	0
1955	0	0	0	0	0	0	0	0	0	0	0	0	0
1956	0	0	0	0	0	0	0	0	0	0	0	0	0
1957	0	0	0	0	0	0	0	0	0	0	0	0	0
1958	0	0	0	0	0	0	0	0	0	0	0	0	0
1959	0	0	0	0	0	0	0	0	0	0	0	0	0
1960	0	0	0	0	0	0	0	0	0	0	0	0	0
1961	0	0	0	0	0	0	0	0	0	0	0	0	0
1962	0	0	0	0	0	0	0	0	0	0	0	0	0
1963	0	0	0	0	0	0	0	0	0	0	0	0	0
1964	0	0	0	0	0	0	0	0	0	0	0	0	0
1965	0	0	0	0	0	0	0	0	0	0	0	0	0
1966	0	0	0	0	0	0	0	0	0	0	0	0	0
1967	0	0	0	0	0	0	0	0	0	0	0	0	0
1968	0	0	0	0	0	0	0	0	0	0	0	0	0
1969	0	0	0	0	0	0	0	0	0	0	0	0	0
1970	0	0	0	0	0	0	0	0	0	0	0	0	0
1971	0	0	0	0	0	0	0	0	0	0	0	0	0
1972	0	0	0	0	0	0	0	0	0	0	0	0	0
1973	0	0	0	0	0	0	0	0	0	0	0	0	0
1974	0	0	0	0	0	0	0	0	0	0	0	0	0
1975	0	0	0	0	0	0	0	0	0	0	0	0	0
1976	0	0	0	0	0	0	0	0	0	0	0	0	0
1977	0	0	0	0	3,233	0	0	0	140	0	0	0	3,373
1978	0	0	0	0	0	0	0	0	0	0	0	0	0
1979	0	0	0	0	0	0	0	0	0	0	0	0	0
1980	0	0	0	0	0	0	0	0	0	0	0	0	0
1981	0	0	0	0	0	0	0	0	0	0	0	0	0
1982	0	0	0	0	0	0	0	0	0	0	0	0	0
1983	0	0	0	0	0	0	0	0	0	0	0	0	0
1984	0	0	0	0	0	0	0	0	0	0	0	0	0
1985	0	0	0	0	0	0	0	0	0	0	0	0	0
1986	0	0	0	0	0	0	0	0	0	0	0	0	0
1987	0	0	0	0	13,863	22,862	3,056	197	0	0	0	0	39,978
1988	0	0	0	0	0	0	0	0	0	0	0	0	0
1989	0	0	0	0	0	0	0	0	0	0	0	0	0
1990	0	0	0	0	0	0	0	0	0	0	0	0	0
1991	0	0	0	0	0	0	0	0	0	0	0	0	0
1992	0	0	0	0	0	0	0	0	0	0	0	0	0
1993	0	0	0	0	0	0	0	0	0	0	0	0	0
1994	0	0	0	0	0	0	0	0	0	0	0	0	0
1995	0	0	0	0	0	0	0	0	0	0	0	0	0
1996	0	0	0	0	0	0	0	0	0	0	0	0	0
AVG	0	0	0	86	318	434	49	3	52	42	26	0	1,011
MAX	0	0	0	5,445	13,863	22,862	3,056	197	1,926	1,801	1,634	0	39,978
MIN	0	0	0	0	0	0	0	0	0	0	0	0	0

MARLETABLE WATER AT THE LOWER HONDO DIVERSION POINT (AF)
Simulated with Nueces Water Availability Model (Runs 3 & 8)

YEAR	JAN	FEB	MAR	APR	MAY	JUN	JUL	AUG	SEP	OCT	NOV	DEC	TOTAL
1934	0	6	9	32	39	0	0	0	0	0	0	0	86
1935	0	0	0	0	0	196	42	89	21	1,210	0	0	1,558
1936	0	37	0	39	0	0	89	26	27,301	7,907	4,384	0	39,783
1937	0	49	0	0	45	60	22	0	0	1	9	0	186
1938	0	0	0	0	702	99	40	4	0	0	0	0	845
1939	5	11	14	0	0	0	0	0	0	34	4	4	72
1940	6	11	17	45	798	257	0	20	1	0	9	0	1,164
1941	30	0	0	0	0	1,932	0	0	2,772	0	0	0	4,734
1942	59	11	18	0	68	75	32	27	2,097	1,831	13	7	4,238
1943	10	11	18	23	26	48	39	4	3	4	4	14	204
1944	11	0	0	0	0	0	107	0	33	17	17	37	222
1945	0	0	960	2,756	0	110	23	0	12	16	5	16	3,898
1946	18	17	12	28	40	24	3	0	39	887	0	19	1,087
1947	9	11	18	23	33	0	63	20	1	0	0	1	179
1948	2	12	14	3	0	2	0	0	0	1	0	0	34
1949	3	0	0	0	1,494	0	33	31	22	33	8	7	1,631
1950	10	11	19	23	32	42	22	0	0	0	0	0	159
1951	0	0	1	5	0	50	0	0	0	0	0	0	56
1952	0	0	0	0	26	27	0	0	6	0	1	32	92
1953	5	6	6	0	0	0	0	5	0	0	74	30	126
1954	9	3	1	4	0	30	0	0	0	1	0	0	48
1955	0	1	5	0	3	0	0	0	0	0	0	0	9
1956	0	0	0	0	0	0	2	0	0	1	0	0	3
1957	0	0	0	0	0	0	23	0	0	0	0	0	23
1958	0	0	0	0	0	0	0	46	0	0	0	0	46
1959	30	0	28	0	0	0	0	30	24	0	0	20	132
1960	10	12	18	22	32	19	0	0	0	0	180	0	293
1961	13	0	23	23	32	0	0	87	24	0	8	7	217
1962	9	6	10	14	13	26	0	0	0	0	1	0	79
1963	1	3	1	9	0	0	0	0	0	0	0	0	14
1964	0	0	0	0	0	0	0	0	0	10	0	8	18
1965	0	0	0	0	0	435	0	0	11	0	38	0	484
1966	54	0	34	0	178	153	0	103	0	30	8	7	567
1967	7	7	0	0	0	0	0	0	0	20	15	0	49
1968	0	0	0	0	0	0	1,374	126	40	20	13	10	1,583
1969	10	11	19	23	0	62	0	0	50	0	60	6	241
1970	10	0	29	23	0	0	0	0	0	0	0	0	62
1971	0	1	1	0	3	4	0	0	0	0	0	0	9
1972	237	0	0	41	0	56	43	0	0	0	0	35	412
1973	0	0	0	0	85	0	0	0	0	0	0	0	85
1974	0	0	0	0	0	0	26	0	320	0	0	0	346
1975	0	0	0	0	0	1,038	884	0	0	0	0	0	1,922
1976	0	0	0	0	0	0	0	0	177	0	0	0	177
1977	0	11	0	0	5,484	901	0	0	0	0	0	0	6,396
1978	0	0	0	0	4	0	2	0	0	11	0	0	17
1979	0	0	0	0	0	0	0	0	0	6	16	0	22
1980	0	16	0	5	0	18	0	4	8,901	21	9	7	8,981
1981	10	0	28	0	0	0	60	38	21	0	8	7	172
1982	10	11	14	12	0	89	25	10	2	1	11	12	197
1983	5	6	0	0	58	0	78	0	17	16	22	15	217
1984	0	15	10	2	0	0	0	0	0	0	2	0	29
1985	0	0	0	39	0	71	42	20	11	0	0	58	241
1986	0	21	19	21	34	0	55	39	0	0	55	0	244
1987	16	11	18	0	29,779	66,855	1,234	0	0	0	32	21	97,966
1988	0	0	0	0	0	0	0	0	3	4	0	0	7
1989	3	29	10	12	6	0	0	0	0	10	26	4	100
1990	5	6	0	0	0	51	0	80	42	29	10	7	230
1991	10	11	12	0	0	92	42	20	0	44	8	0	239
1992	0	0	0	0	0	0	743	0	66	13	0	53	875
1993	23	0	0	49	0	0	0	0	0	0	0	0	72
1994	0	0	23	0	0	0	11	6	2	0	0	0	42
1995	0	0	0	50	0	0	0	5	0	56	0	8	119
1996	0	11	10	2	0	0	0	0	0	0	0	1	24
AVG	10	6	23	53	619	1,156	82	13	667	194	80	7	2,911
MAX	237	49	960	2,756	29,779	66,855	1,374	126	27,301	7,907	4,384	58	97,966
MIN	0	0	0	0	0	0	0	0	0	0	0	0	3

MARKETABLE WATER AT THE LOWER SABINAL DIVERSION LOCATION (AF)
Simulated with Nueces Water Availability Model (Runs 3 & 8)

YEAR	JAN	FEB	MAR	APR	MAY	JUN	JUL	AUG	SEP	OCT	NOV	DEC	TOTAL
1934	1	0	0	0	0	0	0	0	0	0	0	0	1
1935	0	0	0	34	0	110	91	856	65	1,383	0	0	2,539
1936	0	0	0	0	0	0	517	0	51,618	14,229	8,530	0	74,894
1937	0	0	0	0	0	0	0	0	0	0	0	0	0
1938	0	0	0	0	1,131	0	0	0	0	0	0	0	1,131
1939	0	0	0	0	0	0	0	0	0	0	0	0	0
1940	0	0	0	0	2,090	0	1,314	0	0	0	0	0	3,404
1941	0	0	0	0	0	4,689	0	0	4,846	0	0	0	9,535
1942	0	0	0	0	1,693	0	0	0	3,505	2,834	0	0	8,032
1943	0	0	0	0	0	0	0	0	0	0	0	0	0
1944	0	0	0	0	0	0	0	0	0	0	0	0	0
1945	0	0	2,878	5,716	1,929	0	0	0	0	0	0	0	10,523
1946	0	0	0	0	0	0	0	0	0	915	0	0	915
1947	0	0	0	0	188	0	0	0	0	0	0	0	188
1948	0	0	0	0	0	0	0	0	0	0	0	0	0
1949	0	0	0	0	2,639	0	0	0	0	0	0	678	3,317
1950	0	0	0	0	0	0	0	0	0	0	0	0	0
1951	0	0	0	0	0	0	0	0	0	0	0	0	0
1952	0	0	0	0	0	0	0	0	0	0	0	0	0
1953	0	0	0	1	2	0	0	0	0	0	0	0	3
1954	0	0	0	0	0	185	25	0	0	0	0	0	210
1955	0	10	0	0	0	0	0	0	0	0	0	0	10
1956	0	0	0	0	1	0	0	0	0	0	0	0	1
1957	0	0	0	0	0	0	0	0	0	0	0	623	623
1958	0	0	0	0	0	0	0	0	0	0	0	0	0
1959	0	270	0	82	0	0	0	0	0	0	0	0	352
1960	0	332	0	137	102	0	0	0	0	0	1,406	0	1,977
1961	0	0	0	385	130	0	0	238	110	0	0	90	953
1962	0	24	36	0	0	0	0	0	0	0	0	0	60
1963	0	0	0	0	0	0	0	0	0	0	0	0	0
1964	0	0	0	0	0	0	0	0	0	0	0	0	0
1965	0	0	0	0	0	0	0	0	0	0	0	1,590	1,590
1966	0	44	31	0	0	0	0	0	0	0	0	49	124
1967	0	55	0	0	0	0	0	0	0	0	15	0	70
1968	0	0	0	0	0	0	1,641	0	0	73	0	21	1,735
1969	0	29	42	44	72	0	0	0	111	0	0	0	298
1970	0	0	559	0	0	0	62	56	0	0	0	0	677
1971	0	29	51	0	0	94	0	0	0	0	0	0	174
1972	0	0	0	0	0	0	37	0	0	0	0	0	37
1973	0	0	0	0	1	0	0	0	0	0	0	0	1
1974	0	0	0	0	0	0	0	0	0	0	0	0	0
1975	0	0	0	0	0	0	0	0	0	0	0	0	0
1976	0	0	0	0	0	0	0	0	0	0	0	0	0
1977	0	0	0	0	10,905	0	0	0	0	0	0	0	10,905
1978	0	0	0	0	0	0	0	0	0	77	0	0	77
1979	0	0	0	0	0	0	0	0	0	110	0	0	110
1980	0	68	0	36	0	10	12	0	12,636	0	0	0	12,762
1981	0	0	696	0	0	0	0	0	0	0	0	0	696
1982	0	0	0	0	0	0	93	46	90	55	0	51	335
1983	0	0	0	0	0	0	0	0	0	0	0	0	0
1984	0	0	11	0	0	0	0	0	0	0	0	0	11
1985	0	0	0	0	0	96	0	0	48	0	0	0	144
1986	0	76	58	25	0	0	65	0	0	0	0	0	224
1987	0	0	0	0	25,541	92,958	13,004	0	0	0	0	0	131,503
1988	0	0	0	0	0	0	0	0	118	0	0	0	118
1989	0	0	0	33	58	39	7	15	0	0	51	66	269
1990	0	0	0	0	0	0	0	0	0	0	0	0	0
1991	0	816	52	0	0	29	0	22	0	0	0	0	919
1992	0	0	0	0	0	0	0	0	0	0	0	0	0
1993	0	0	0	0	0	0	0	0	0	0	0	0	0
1994	0	0	0	0	0	0	0	17	27	0	0	0	44
1995	0	0	0	0	0	0	0	0	0	0	0	0	0
1996	0	0	0	20	12	0	0	0	0	0	0	0	32
AVG	0	28	70	103	738	1,559	268	20	1,161	312	159	50	4,469
MAX	1	816	2,878	5,716	25,541	92,958	13,004	856	51,618	14,229	8,530	1,590	131,503
MIN	0	0	0	0	0	0	0	0	0	0	0	0	0

MARKETABLE WATER AT THE LOWER FRIO DIVERSION POINT (AF)
Simulated with Nueces Water Availability Model (Runs 3 & 8)

YEAR	JAN	FEB	MAR	APR	MAY	JUN	JUL	AUG	SEP	OCT	NOV	DEC	TOTAL
1934	216	753	760	1,271	1,290	237	144	138	114	177	243	0	5,343
1935	538	582	463	594	0	929	807	1,049	413	1,696	0	0	7,071
1936	0	0	0	0	0	0	1,841	996	55,193	15,689	9,783	0	83,502
1937	0	0	0	0	1,257	0	810	516	540	743	921	0	4,787
1938	0	0	0	0	2,717	1,248	810	592	545	567	512	673	7,664
1939	0	817	797	579	389	202	0	0	706	1,159	1,070	1,009	6,728
1940	890	1,010	917	1,514	3,086	0	2,767	864	676	639	891	0	13,254
1941	0	0	0	0	0	4,430	0	0	6,438	0	0	0	10,868
1942	0	1,458	1,367	0	3,344	1,168	941	1,031	5,304	4,687	0	0	19,300
1943	1,433	1,101	1,091	1,153	913	964	647	287	502	645	619	866	10,221
1944	0	0	0	1,516	0	0	1,092	1,453	0	1,602	1,203	1,470	8,336
1945	0	0	2,728	3,200	2,298	954	518	248	277	424	988	1,177	12,812
1946	1,008	949	810	724	960	473	376	121	528	1,122	0	1,506	8,577
1947	0	0	0	1,747	2,457	0	2,697	1,010	690	652	774	978	11,005
1948	872	867	773	600	436	404	180	55	190	353	410	520	5,660
1949	626	0	0	0	3,030	0	814	562	946	1,231	1,070	1,169	9,448
1950	1,187	1,119	1,116	898	883	630	352	275	371	464	384	542	8,221
1951	438	486	656	668	0	632	49	0	692	192	339	454	4,606
1952	447	403	445	555	684	329	7	0	0	0	86	0	2,956
1953	0	0	0	179	0	0	0	0	0	318	330	0	827
1954	0	0	0	0	0	616	559	0	0	0	0	0	1,175
1955	0	269	0	0	0	0	0	0	0	12	0	0	281
1956	0	0	0	0	0	0	0	0	0	0	0	0	0
1957	0	0	458	0	0	0	0	0	0	0	0	1,700	2,158
1958	0	2,043	0	0	1,764	0	0	0	0	0	0	4,410	8,217
1959	2,976	2,031	1,806	1,723	0	0	0	2,662	0	0	2,815	2,359	16,372
1960	0	2,246	2,208	1,826	1,392	857	1,806	0	2,523	0	3,876	0	16,734
1961	3,949	413	4,239	2,935	2,102	0	0	2,508	1,959	0	2,008	1,894	22,007
1962	0	1,272	1,107	1,201	0	1,978	0	0	98	0	0	0	5,656
1963	1,032	950	1,038	0	0	407	0	0	0	0	0	0	3,427
1964	0	0	0	0	1,015	0	0	61	0	0	0	0	1,076
1965	0	0	0	0	0	5,687	0	0	0	0	0	1,251	6,938
1966	0	1,104	1,154	0	0	0	0	0	0	0	0	1,667	3,925
1967	0	1,249	0	0	0	0	0	0	460	0	18	0	1,727
1968	0	0	0	0	0	0	2,558	0	0	1,525	0	1,643	5,726
1969	0	1,237	1,249	1,494	1,371	0	0	0	710	0	0	0	6,061
1970	0	0	2,981	0	0	0	1,647	1,136	0	0	0	0	5,764
1971	0	1,174	1,292	0	0	483	0	0	0	0	0	4,425	7,374
1972	3,130	0	0	0	0	0	2,028	0	0	0	0	0	5,158
1973	0	0	0	0	1,397	0	0	0	2,442	0	0	3,631	7,470
1974	0	0	0	0	0	0	0	0	2,095	0	0	0	2,095
1975	0	0	0	0	0	0	0	0	0	0	0	0	0
1976	0	0	0	0	0	0	0	0	2,193	2,304	397	2,743	7,637
1977	0	256	0	0	7,389	3,682	0	0	0	0	0	0	11,327
1978	2,376	0	0	0	875	0	419	0	1,711	1,573	0	0	6,954
1979	0	0	0	0	0	0	0	0	0	1,118	0	0	1,118
1980	0	1,384	0	986	999	675	264	0	24,581	0	0	0	28,889
1981	0	0	4,817	0	0	0	0	0	0	0	0	0	4,817
1982	0	0	0	0	0	0	1,535	1,061	1,108	1,088	0	1,570	6,362
1983	0	0	0	0	881	0	0	786	0	0	0	1,850	3,517
1984	1,651	0	1,080	0	0	0	0	0	0	296	1,647	0	4,674
1985	0	0	0	3,204	0	1,983	0	0	993	0	3,222	0	9,402
1986	0	1,661	1,473	1,369	0	0	1,681	0	0	0	4,724	0	10,908
1987	0	0	4,785	0	31,468	79,103	17,638	0	0	0	0	0	132,994
1988	0	0	0	0	0	0	0	0	1,794	0	0	0	1,794
1989	0	0	0	1,550	1,191	695	394	486	403	0	1,317	1,224	7,260
1990	1,101	1,411	2,043	2,363	0	1,677	0	0	3,414	2,901	2,476	2,209	19,595
1991	0	1,778	1,580	0	1,393	1,002	0	654	0	0	0	0	6,407
1992	0	0	0	0	0	0	0	0	0	0	-2,118	2,470	352
1993	2,625	2,449	2,520	0	2,249	1,294	730	466	0	910	0	0	13,243
1994	0	1,309	0	0	0	0	3,767	2,171	1,467	1,274	1,570	0	11,558
1995	2,497	1,823	2,452	0	0	0	0	0	0	2,286	0	0	9,058
1996	0	0	1,149	957	790	0	0	0	0	0	0	3,236	6,132
AVG	460	565	815	552	1,270	1,790	792	336	1,938	756	660	772	10,707
MAX	3,949	2,449	4,817	3,204	31,468	79,103	17,638	2,662	55,193	15,689	9,783	4,425	132,994
MIN	0	0	0	0	0	0	0	0	0	0	-2,118	0	0

MARKETABLE WATER AT THE INDIAN CREEK DIVERSION POINT (AF)
Simulated with Nueces Water Availability Model (Runs 3 & 8)

YEAR	JAN	FEB	MAR	APR	MAY	JUN	JUL	AUG	SEP	OCT	NOV	DEC	TOTAL
1934	0	0	0	0	0	0	0	0	0	0	0	0	0
1935	0	0	0	0	58,297	761	0	0	302	0	0	0	59,360
1936	0	0	0	0	0	0	523	0	0	0	0	0	523
1937	0	0	0	0	0	0	0	0	0	0	0	0	0
1938	0	0	0	0	0	0	0	0	0	0	0	0	0
1939	0	0	0	0	0	0	0	0	0	0	0	0	0
1940	0	0	0	0	0	0	0	0	0	0	0	0	0
1941	0	0	0	0	0	0	0	0	0	0	0	0	0
1942	0	0	0	0	0	0	0	0	0	0	0	0	0
1943	0	0	0	0	0	0	0	0	0	0	0	0	0
1944	0	0	0	0	0	0	0	0	0	0	0	0	0
1945	0	0	0	0	0	0	0	0	0	0	0	0	0
1946	0	0	0	0	0	0	0	0	0	0	0	0	0
1947	0	0	0	0	0	0	0	0	0	0	0	0	0
1948	0	0	0	0	0	0	0	0	0	0	0	0	0
1949	0	0	0	0	0	0	0	7,062	0	0	0	0	7,062
1950	0	0	0	0	0	0	0	0	0	0	0	0	0
1951	0	0	0	0	0	0	0	0	0	0	0	0	0
1952	0	0	0	0	0	0	0	0	0	0	0	0	0
1953	0	0	0	0	0	0	0	0	13,814	0	0	0	13,814
1954	0	0	0	0	590	0	0	0	0	0	0	0	590
1955	0	0	0	0	0	0	0	0	0	0	0	0	0
1956	0	0	0	0	0	0	0	0	0	0	0	0	0
1957	0	0	0	0	0	0	0	0	0	0	0	0	0
1958	0	0	0	0	0	161,514	0	0	0	182	163	0	161,859
1959	0	0	0	0	0	15,703	0	0	14,211	178	0	0	30,092
1960	0	0	0	0	0	0	0	0	0	0	8,636	2,910	11,546
1961	3,563	353	0	0	0	0	4,594	0	0	0	0	0	8,510
1962	0	0	0	0	0	0	0	0	0	0	0	0	0
1963	0	0	0	0	0	0	0	0	0	0	0	0	0
1964	0	0	0	0	0	0	0	0	0	0	0	0	0
1965	0	0	0	0	0	0	0	0	0	0	0	0	0
1966	0	0	0	0	0	0	0	0	0	0	0	0	0
1967	0	0	0	0	0	0	0	0	0	0	0	0	0
1968	185	2,519	0	0	500	0	0	0	0	0	0	0	3,204
1969	0	0	0	0	0	0	0	0	0	0	0	0	0
1970	0	0	0	0	0	0	0	0	0	0	0	0	0
1971	0	0	0	0	0	0	0	497	299	175	212	8,590	9,773
1972	0	0	0	0	0	0	0	0	0	0	0	0	0
1973	0	0	0	0	0	0	4,316	0	0	253	210	0	4,779
1974	0	0	0	0	0	0	0	0	3,480	0	0	0	3,480
1975	0	0	0	0	0	0	24,094	0	0	0	0	0	24,094
1976	0	0	0	0	0	0	0	0	19,366	16,923	586	185	37,060
1977	8,062	10,009	0	2,919	28,894	0	0	0	0	0	0	0	49,884
1978	0	0	0	0	0	0	0	0	0	0	0	0	0
1979	0	0	0	0	0	0	0	0	0	0	0	0	0
1980	0	0	0	0	0	0	0	0	0	0	0	0	0
1981	0	0	0	0	4,021	649	576	0	0	128,034	12,303	0	145,583
1982	0	0	0	0	17,725	0	0	0	0	0	0	0	17,725
1983	0	0	0	0	0	0	0	0	0	0	0	0	0
1984	0	0	0	0	0	0	0	0	0	0	0	0	0
1985	0	0	0	0	0	0	0	0	0	34,247	1,092	0	35,339
1986	0	0	0	0	0	0	0	0	0	0	0	0	0
1987	0	0	0	0	0	392	685	0	0	0	0	0	1,077
1988	0	0	0	0	0	0	0	0	0	0	0	0	0
1989	0	0	0	0	0	0	0	0	0	0	0	0	0
1990	0	0	0	0	0	0	0	0	0	0	0	0	0
1991	0	0	0	0	0	0	0	0	32,477	0	2,800	0	35,277
1992	0	22,950	51,429	460	601	715	13,416	0	0	0	0	0	89,571
1993	0	0	0	0	0	0	0	0	0	0	0	0	0
1994	0	0	0	0	0	0	0	0	0	0	0	0	0
1995	0	0	0	0	0	0	0	0	0	0	0	0	0
1996	0	0	0	0	0	0	0	0	0	0	0	0	0
AVG	187	569	816	54	1,756	2,853	765	120	1,333	2,857	413	185	11,908
MAX	8,062	22,950	51,429	2,919	58,297	161,514	24,094	7,062	32,477	128,034	12,303	8,590	161,859
MIN	0	0	0	0	0	0	0	0	0	0	0	0	0

APPENDIX C

APPENDIX C: Conceptual Engineering and Cost Estimates

Edwards Aquifer Recharge and Recirculation Analysis

Prepared for Todd Engineers, California

By



NRS Consulting Engineers, Texas



A handwritten signature in black ink, appearing to read "Joseph W. Norris".

FINAL
December 19, 2008

Contents

List of Tables and Figures	3
Introduction	4
Objectives	4
Approach and Methods	4
<i>Elements Evaluated</i>	4
<i>Engineering Considerations</i>	5
<i>Cost Determinations</i>	9
Results	11
Recharge Structures	11
<i>Cost Estimates</i>	12
Pipelines	13
<i>Cost Estimates</i>	14
<i>Location</i>	15
<i>Profiles</i>	26
Planning Considerations	33
Engineering Approach.....	33
Cost Assumptions	33
<i>Purchased Water Costs</i>	33
Environmental Issues	34
<i>Study Requirements</i>	34
<i>Permitting Requirements</i>	35
References	37
ANNEX 1: General Guidelines for Regional Water Plan Development (2007-2012) [Final Draft]	38
ANNEX 2: Cost Estimation Procedures for the South Central Texas Region (Region L) [Provisional]	54

List of Tables and Figures

Tables

Table C-1:	Master list of facility elements evaluated.....	5
Table C-2:	Summary of required cost estimate components and assumptions.....	10
Table C-3:	Summary of selected physical data for recharge structures.	11
Table C-4:	Cost estimate summary for recharge structure elements.....	12
Table C-5:	Summary of selected physical data for pipeline elements: P-1 through P-6. ...	13
Table C-6:	Summary of selected physical data for pipeline elements: P-7 through P-10..	13
Table C-7:	Cost estimate summary for pipeline elements: P-1 through P-6.	14
Table C-8:	Cost estimate summary for pipeline elements: P-7 through P-10.....	15

Figures

Figure C-1:	Location of recharge structures.	6
Figure C-2:	Conceptual layout of well field elements located in Medina and Uvalde counties, Texas.....	8
Figure C-3:	Conceptual location for RS-1 (Lower Blanco) and P-1 (Lower Blanco to a flood retention structure).....	16
Figure C-4:	Conceptual location for RS-2 (Cibolo) and P-2 (Canyon Lake to Cibolo).	17
Figure C-5:	Conceptual location for RS-2 (Cibolo) and P-3 (Lake Dunlap to Cibolo).....	18
Figure C-6:	Conceptual location for RS-3 (San Geronimo) and P-4 (Lake Dunlap to San Geronimo).	19
Figure C-7:	Conceptual location for RS-4 (Lower Verde) and P-5 (Lake Dunlap to Lower Verde).....	20
Figure C-8:	Conceptual location for RS-8 (Indian Creek) and P-10 (Indian Creek to Dry Frio Type 2).....	21
Figure C-9:	Conceptual location for RS-9 (Upper Seco Creek) and P-8 (Seco Creek Type 2 to Upper Seco Creek).	22
Figure C-10:	Conceptual location for P-6.1 (Guadalupe River to Medina Lake Tributary) and P-6.2 (Medina Lake to San Geronimo).....	23
Figure C-11:	Conceptual location for Pw-7 (Medina Well Field to Seco Creek Type 2).....	24
Figure C-12:	Conceptual location for Pw-9 (Uvalde Well Field to Dry Frio Type 2).	25
Figure C-13:	Profile for P-1 (Lower Blanco to flood retardation structure).	26
Figure C-14:	Profile for P-2 (Canyon Lake to Cibolo).	26
Figure C-15:	Profile for P-3 (Lake Dunlap to Cibolo).....	27
Figure C-16:	Profile for P-4 (Lake Dunlap to San Geronimo).	27
Figure C-17:	Profile for P-5 (Lake Dunlap to Lower Verde).	28
Figure C-18:	Profile for P-6.1 (Guadalupe River to Lake Medina Tributary).	28
Figure C-19:	Profile for P-6.2 (Medina Lake to San Geronimo).	29
Figure C-20:	Profile for Pw-7 (Medina Well Field to Seco Creek Type 2).	29
Figure C-21:	Profile for P-8 (Seco Creek Type 2 to Upper Seco Creek).	30
Figure C-22:	Profile for Pw-9 (Seco Creek Type 2 to Upper Seco Creek).	30
Figure C-23:	Profile for P-10a (Indian Creek to Dry Frio Type 2).	31
Figure C-24:	Profile for P-10b (Indian Creek to Dry Frio Type 2).	31
Figure C-25:	Profile for P-10a (Indian Creek to Dry Frio Type 2).	32

Introduction

In September 2006, Todd Engineers contracted with NRS Consulting Engineers (NRS) to perform conceptual engineering and prepare cost estimates for various recharge and recirculation elements being considered for the Edwards Aquifer, Texas. Modular costs for various water development and conveyance facilities (elements) being evaluated in Chapter 6 are presented in this Appendix and include recharge structures, conveyance pipelines, and well field systems.

Objectives

Specific project objectives delegated to NRS include:

Task 4.1 Engineering Considerations

Optimum recharge and recirculation facility locations (Task 2) and source feasible information (Task 3) will be combined into several water management components for water supply and spring flow maintenance. Specified engineering deliverables included:

- Maps depicting all recharge and recirculation elements
- Pipeline route selection
- Pipeline profiles

Task 4.2 Cost Determinations

Cost information for each recharge and recirculation element will be estimated pursuant to planning guidelines for the South Central Texas Regional Planning Group (Region L).

Specified cost estimate deliverables include:

- Capital equipment and maintenance costs (including land acquisition, pipelines, transfer pump stations, intake structures, treatment plants, recharge dams, and water rights)
- Detailed cost spreadsheets for each element

Approach and Methods

ELEMENTS EVALUATED

Todd Engineers provided NRS with a list of facility elements to be evaluated (Table C-1). The list specified the type and approximate capacity of each element, which included variations of nine (9) different recharge structures (RS) and ten (10) pipeline alignments (P). Two of the pipeline elements include well fields and associated collection systems (Pw). Todd Engineers also provided references to existing planning and engineering studies that have evaluated the subject facility elements.

Table C-1: Master list of facility elements evaluated.

Element ID	Location	Facility
RS-1	Lower Blanco	Type 2 Recharge Structure
RS-2a	Cibolo	Type 2 Recharge Structure
RS-2b	Cibolo	Type 2 Recharge Structure
RS-3	San Geronimo	Type 2 Recharge Structure
RS-4	Lower Verde	Type 2 Recharge Structure
RS-5	Lower Hondo	Type 2 Recharge Structure
RS-6	Lower Sabinal	Type 2 Recharge Structure
RS-7	Lower Frio	Type 2 Recharge Structure
RS-8	Indian Creek	Type 2 Recharge Structure
RS-9	Upper Seco Creek	Type 1 Recharge Structure
P-1	Lower Blanco Type 2 to Flood Retarding Structure	Pipeline
P-2	Canyon Lake to Cibolo	Pipeline
P-3	Lake Dunlap to Cibolo	Pipeline
P-4	Lake Dunlap to San Geronimo	Pipeline
P-5	Lake Dunlap to Lower Verde	Pipeline
P-6.1	Guadalupe River to Medina Lake Tributary	Pipeline
P-6.2	Medina Lake to San Geronimo	Pipeline
Pw-7	Medina Well Field to Seco Creek Type 2	Pipeline with Well Field
P-8	Seco Creek Type 2 to Upper Seco Creek	Pipeline
Pw-9	Uvalde Well Field to Dry Frio Type 2	Pipeline with Well Field
P-10a	Indian Creek Type 2 to Dry Frio Type 2	Pipeline
P-10b	Indian Creek Type 2 to Dry Frio Type 2	Pipeline

ENGINEERING CONSIDERATIONS

Recharge Structures

Todd Engineers provided NRS with a map indicating the location of each recharge structures (Figure C-1). NRS used the existing physical data (including dam type, recharge pool capacity, top of dam elevation, stream bed elevation, spillway elevation, spillway width, and flood pool elevations) without modification and did not re-evaluate the preliminary design of each recharge structure. (These data are reproduced in Table C-3).

The original Type 2 exhibits from previous recharge reports were overlaid on current (2008) aerial photographs from Google or Microsoft Live maps. Comparison of the desired water surface for the selected project size was compared with the imagery for new encroachments from recent developments, roads, and bridges. In some cases, USGS topographic maps were also when the specified flood pool elevation extended beyond the original exhibit. The number and extent of necessary road and bridge relocations was then determined for each element.

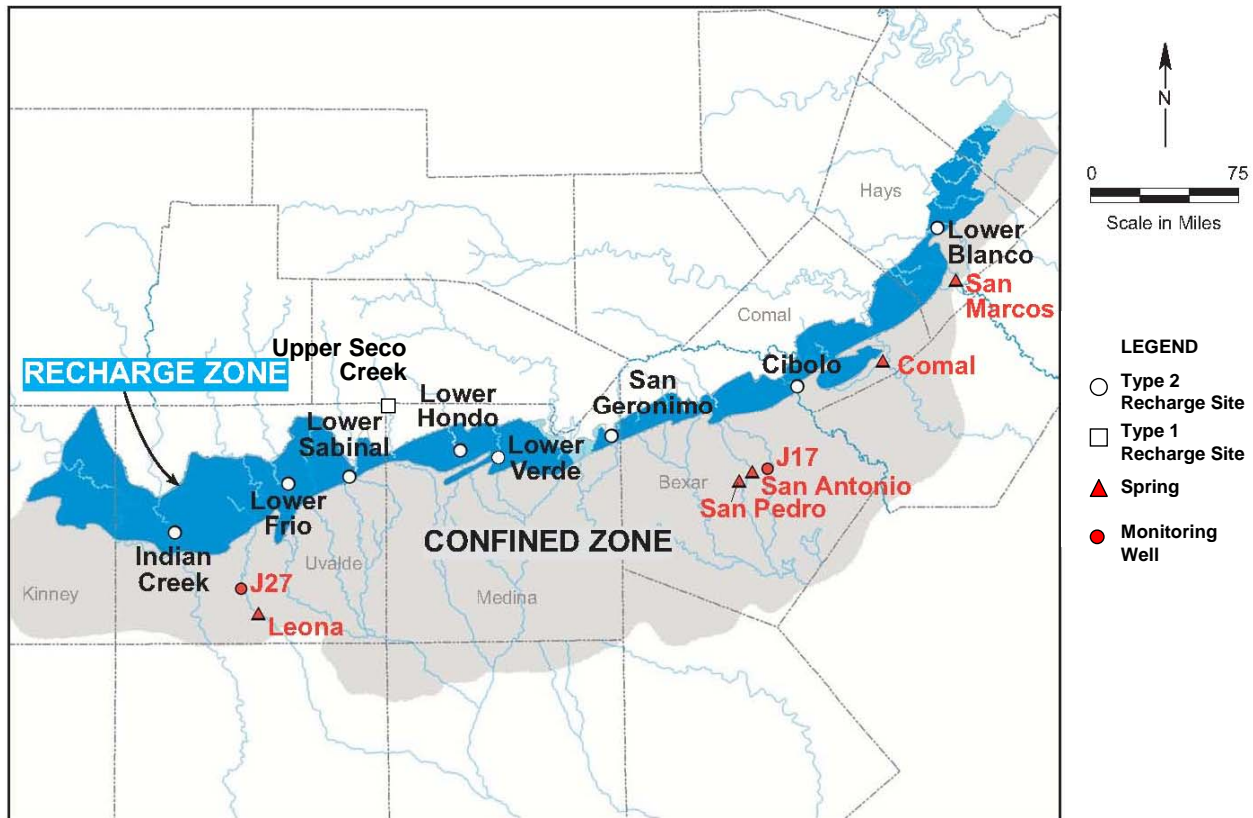

Figure C-1: Location of recharge structures.

Pipelines

The scope of the project covers more than seven counties in central Texas and required extensive geographic research from various sources. For topographic information the U.S. Geological Survey quad sheets available online, were used extensively. Digital imagery (ortho-photo) at 1 meter resolution (2004) provided from the Texas Natural Resources Information System was consulted for initial layouts. Recent (2004 or newer) imagery from Google Earth was also used to confirm suspected areas of high growth. U.S. Fish and Wildlife and Texas Parks and Wildlife mapping data of sensitive resources were also utilized. Finally, the Edward Aquifer authority was invaluable in providing GIS layers and shape files of existing infrastructure and hydrology.

Initial determination of proposed alignments began by consulting previous reports and studies. Existing alignments were extracted into either AutoCAD or ArcView format and checked for overall feasibility. This included an evaluation of any factor that might adversely affect implementation costs, such as geographic impediments, growth of residential development, and environmentally sensitive areas. Unlike with the recharge structure elements, detailed alignments for the alternative pipelines did not exist in previous planning documents other than at a very general scale.

Placement of alignments entailed determining the shortest route between the proposed structures generally along existing right-of-way routes. Major corridors such as interstate highways were consciously avoided as these were assumed to be congested high concentration of utility infrastructure and seemed unlikely to provide the necessary offset

and spacing for installation of the proposed pipeline. When possible, alignments that resulted in new ground disturbance, especially through heavily vegetated or urbanized areas, were avoided due to anticipated higher land acquisition, environmental review, and permitting costs. Residential areas were also avoided as much as possible to minimize construction costs.

For each pipeline element, Todd Engineers specified a volume of water to be pumped to the pipeline terminus. NRS located the intake location and discharge points on USGS topographic maps. A preliminary analysis was made for estimating the approximate size and number of pipelines needed to carry the specified volume over the observed terrain. Considerations were given to elevation changes and head losses for various conditions. In some cases, pipeline sizes were specified from previous studies. A layout of the profile was then placed on the maps, and further evaluation of head losses was then prepared.

Elevation data at points along the pipeline profile were acquired from USGS topographic maps and used to calculate pressures in the conveyance system. As calculated pressures dropped in the pipelines from friction head loss or elevation changes, additional pump stations were added to send the water to its destination. Generally, the pressure at the intake pump station was initially targeted to be below 150 psi. In some cases, higher psi values were used to minimize the requirement to pump the water again along the pipeline. When pressures fell below 40 psi in the pipeline, a pump station was added to that segment of line. These pump stations were located ahead of significant terrain changes where pumping over a high point was desired. The pressures required in the pipelines were used to size pumps and corresponding horsepower requirements for the pump stations. Pump Flow software was used to determine applicable pump and horsepower conditions.

Well Fields

Two pipeline elements also included well field and collection systems; one in Medina County (Pw-7) and one in Uvalde County (Pw-9). All wells within each well field would be linked to a common collection system for transmission into the pipeline (Figure C-2).

The Medina well field was conceptually designed to include 33 wells (including two extra wells to accommodate full field production during maintenance) spaced at 1,000 feet and completed to 700 feet in depth. Each well was assumed to produce 2,000 gpm and would be operated year round.

The Uvalde well field was conceptually designed to include 20 wells (also including two extra wells to accommodate full field production during maintenance) spaced at 1,000 feet and completed to 700 feet in depth. Each well was assumed to produce 1,800 gpm and would be operated year round.

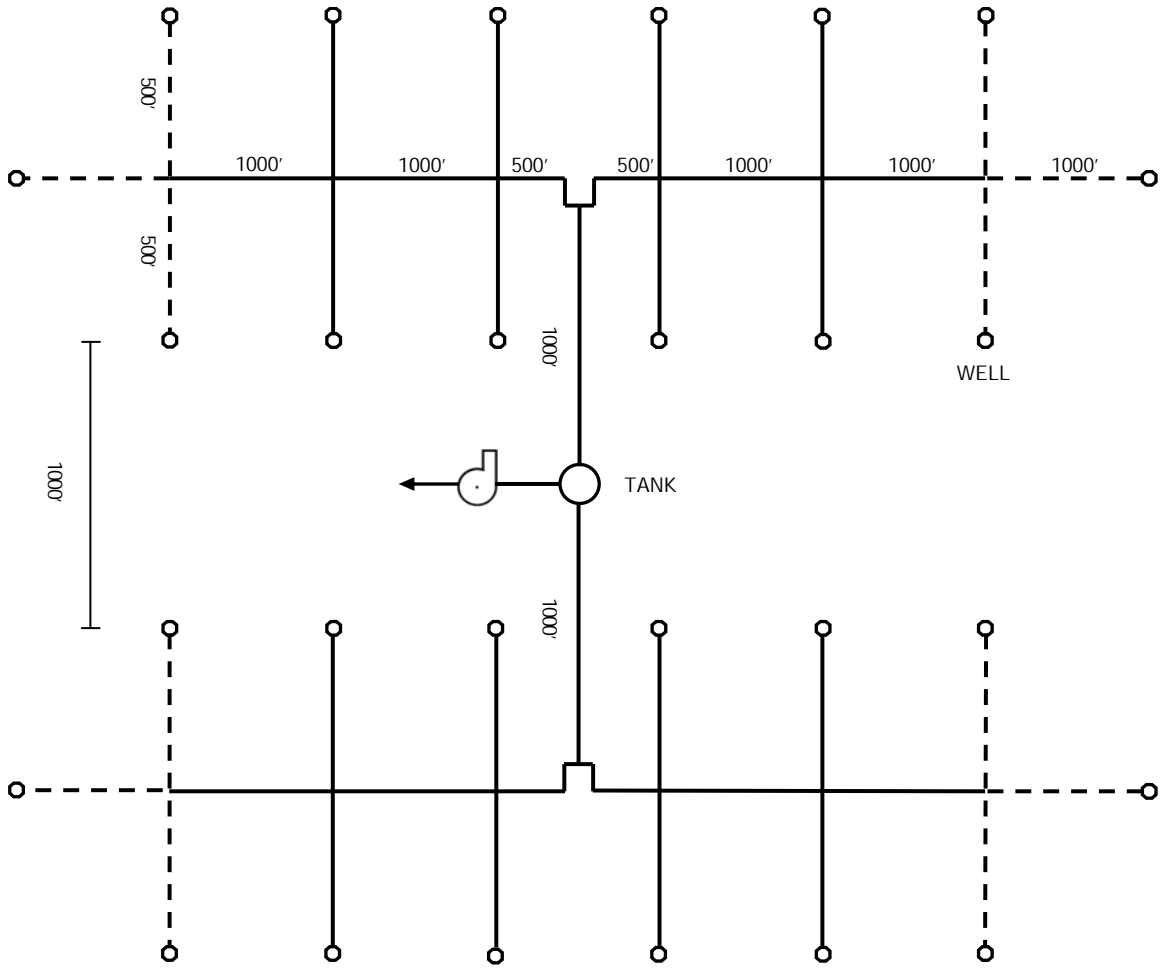

Figure C-2: Conceptual layout of well field elements located in Medina and Uvalde counties, Texas.

COST DETERMINATIONS

Cost Estimating Guidelines and Procedures

Planning-level cost information for the recharge and recirculation facilities were developed in anticipation of their possible inclusion as water management strategies in the South Central Texas Regional Planning Group (Region L) water plan. This included using two sources¹ that defined the cost estimation method:

General Guidelines for Regional Water Plan Development (2007-2012) – Prepared by the Texas Water Development Board (2008), this document summarizes guidelines for developing and/or reevaluating regional water plans for the current planning cycle. The third round of regional and state water planning as defined by Senate Bill 1 of the 75th Texas Legislature commenced in 2007 and will extend through 2012. In general, regions will focus on specific areas of water demand and water supply availability; evaluations of new water management strategies in response to changed conditions; environmental studies or work to further the implementation of water management strategies recommended in previous plans, reevaluations of population and water demand projections only under the presence of changed conditions; updating the costs of water management strategies, interregional coordination; infrastructure financing surveys and administrative and public participation activities. This document is included for reference as *Annex 1*.

Studies Level Engineering and Costing Methodology for Pipelines, Pump Stations, and Other Facilities – Prepared by HDR Engineering, Inc. (undated), this document essentially revises the provisional cost estimation procedures for the South Central Texas Region (Region L). The procedures prescribe cost values to be used for a variety of water supply and distribution infrastructure based on values current as of 2nd Quarter 2007. A studies level cost estimate is to include three major cost categories: construction costs or capital costs, other project costs, and annual costs. Construction costs are the direct costs, such as those for materials, labor, and equipment, incurred in constructing facilities. These are the costs that are submitted by a contractor bidding on a project. “Other project costs” include additional expenses not directly associated with construction activities of the project such as costs for engineering, land acquisition, contingencies, studies, and interest during construction. Capital costs and other project costs comprise the total project cost. Operation and maintenance (O&M), energy costs, and debt service payments are examples of annual costs. This document is included for reference as *Annex 2*.

NRS prepared all cost estimates consistent with the standards presented in these two documents, which called for estimates for numerous components (Table C-2).

Comparison with Previous Estimates

Most of the aquifer recharge and recirculation items considered in the present work have been previously studied in reports dating from 1991 to 2001. In many cases, cost estimates for these items were developed and included in those studies. However, direct comparison of estimates derived in the present study with previous estimates *is not appropriate* for two primary reasons: inconsistent methodology (all of the previous estimates were derived without using a standardized method) and varying inflationary pressures (the previous estimates represent cost conditions for various years, including 1991, 1994, 1998, and 2001).

¹ It should be noted that, at the time of publication of the present work, neither source has been formally approved by the Texas Water Development Board.

Table C-2: Summary of required cost estimate components and assumptions.

Required Cost Component^a	Assumptions
CAPITAL COSTS	
1 Pump Stations	Varies by discharge and pumping head requirements; includes intakes, pump sizes, horsepower, power usage, and power connection costs.
2 Pipelines	Varies by pipe diameter, pipe length, pressure, and soil type.
3 Water Treatment Plants	Estimates include level two (or simple filtration) treatment for recharge water; assumes raw water pumping head of 100' and finished water pumping head of 300'.
4 Water Storage Tanks	Varies by capacity; estimates includes one tank located at each booster station along pipeline alignment providing storage for 5% of daily flow.
5 Off Channel Reservoir	-
6 Well Fields - Public	-
a Public	-
b Irrigation	Estimate assumes each well completed to a depth of 700 feet and an individual production capacity of about 1,900 to 2,500 gpm (same size casing as for 1,800 gpm).
c ASR Wells	-
7 Dams and Reservoirs	Estimates represent indexed value of previous cost calculations based on Engineering News Record publication of the construction cost index values under the Construction Cost Index History (1908-Present).
8 Relocations	Estimates Include facilities and roads; assumes two-lane highway (44 ft section) = \$250/linear foot and 4-lane asphalt (88 ft section) = \$500/linear foot.
9 Water Distribution System Improvements	Varies by individual site needs.
10 Other Items	-
OTHER COSTS	
1 Engineering	Estimates include feasibility studies; assumes engineering costs = 30% of total construction costs for pipeline projects and 35% of total for other facilities.
2 Land and Easements	Varies by project component type; estimates assume land and easement costs for dams and reservoirs = inundated area (assumed to be equal to the 100-year flood pool acreage) times applicable cost value derived from ASFMRA (2007); pipelines = \$8,712 per acre (easements); and well fields = 0.5 acre per well times applicable cost value derived from ASFMRA (2007).
3 Environmental Studies and Mitigation	Varies by project component type; estimates assume environmental and mitigation study costs for dams and reservoirs = 100 percent of land costs; pipelines = \$25,000 per mile; and well fields = 100 percent of land costs.
4 Interest During Construction	Estimates assume interest earned during construction = total interest accrued during construction period (estimated by NRS) using 6% annual interest rate less 4% rate of return on investment of unspent funds.
ANNUAL COSTS	
1 Debt Service	Varies by project component type; estimates assume debt service for dams and reservoirs = 40 years at 6.0% interest; and for pipelines and well fields = 20 years at 6.0% interest.
2 Operation and Maintenance	Varies by quantity of water supply; estimates assume O&M cost for pipeline = 1.0% total estimated construction cost; for pump stations = 2.5%; and for dams = 1.5%.
3 Pumping Energy Costs	Varies by annual calculated power load; assumes power rate = \$0.09 per kWh.
4 Purchase Water Cost	No value included for surface water rights due to uncertainty in determining reliable cost estimates for acquisition or leasing; purchase water costs for groundwater were estimated to be \$127.50 per acre-foot per year based on current 10-year lease agreement estimates (Thompson 2008).

^a Texas Water Development Board (2008) and HDR (undated).

Results

Recharge Structures

The physical data of each recharge structure element evaluated is summarized in Table C-3.

Table C-3: Summary of selected physical data for recharge structures.

ELEMENT NO.	RS-1	RS-2a	RS-2b	RS-3	RS-4	RS-5	RS-6	RS-7	RS-8	RS-9
RECHARGE STRUCTURE	Lower Blanco	Cibolo	Cibolo	San Geronimo	Lower Verde	Lower Hondo	Lower Sabinal	Lower Frio	Indian Creek	Upper Seco Creek
TYPE	Type 2	Type 2	Type 2	Type 2	Type 2	Type 2	Type 2	Type 2	Type 2	Type 1
RECHARGE POOL										
Capacity (acre-feet)	50,000	10,000	50,000	3,500	3,600	2,800	8,750	17,500	61,750	23,000
Surface Area (acres)	1,408	476	1,621	183	334	232	454	1,099	3,657	900
Elevation (ft msl)	752.2	871.9	913	1,083.2	990.6	1,066.5	1,141.6	1,101.4	993	1,441.1
SPILLWAY										
Elevation (ft msl)	757.2	871.9	918	1,088.2	995.6	1,066.5	1,141.6	1,106.4	1,009.2	n/a
Width (ft)	1,500	1,000	1,000	850	700	1,300	1,000	2,000	4,000	n/a
FLOOD POOL										
Elevation (ft msl)	766.9	882.4	919.7	1,095.2	1,004.8	1,074.3	1,152.2	1,115.7	1,013.1	1,450.4
Surface Area (acres)	1,932	672	1,865	265	1,014	384	675	1,546	7,772	1,130
DAM										
Type	Embk	Comp	Embk	Embk	Embk	RCC	RCC/EC	Embk	Embk	n/a
Top Elevation (ft msl)	787.0	900.9	948.2	1,108.8	1,021.2	1,088.2	1,170.8	1,131.7	1,026.3	1,465.9
Toe Elevation (ft msl)	647.0	804.0	804.0	1,030	941.8	1,030	1,073	1,038	924.4	n/a
SOURCE										
	HDR 1998	HDR 1998	HDR 1998	HDR 1998	HDR 1994	HDR 1994	HDR 1994	HDR 1994	HDR 1994	HDR 1991

Note: Embk = Embankment; Comp = Composite; RCC = Reinforced Concrete; EC = Earth Composite

COST ESTIMATES

Estimated cost for each recharge structure element are presented in Table C-4.

Table C-4: Cost estimate summary for recharge structure elements.

ELEMENT NO.	RS-1	RS-2a	RS-2b	RS-3	RS-4	RS-5	RS-6	RS-7	RS-8	RS-9
RECHARGE STRUCTURE	Lower Blanco	Cibolo	Cibolo	San Geronimo	Lower Verde	Lower Hondo	Lower Sabinal	Lower Frio	Indian Creek	Upper Seco Creek
ESTIMATED COST (millions of dollars ^a)										
CAPITAL COSTS										
1 Pump Stations	-	-	-	-	-	-	-	-	-	-
2 Pipelines	-	-	-	-	-	-	-	-	-	-
3 Water Treatment Plants	-	-	-	-	-	-	-	-	-	-
4 Water Storage Tanks	-	-	-	-	-	-	-	-	-	-
5 Off Channel Reservoir	-	-	-	-	-	-	-	-	-	-
6 Well Fields (Irrigation)	-	-	-	-	-	-	-	-	-	-
7 Dams and Reservoirs	36.1	10.3	15.4	5.2	4.2	7.9	9.6	34.6	73.9	13.8
8 Relocations	4.2	0.6	2.3	-	5.2	2.9	0.5	2.1	8.1	5.1
9 Water Distribution System Improvements	-	-	-	-	-	-	-	-	-	-
10 Other Items	-	-	-	-	-	-	-	-	-	-
Total Capital Cost	40.3	10.9	17.8	5.2	9.4	10.8	10.1	36.7	82.0	18.9
OTHER COSTS										
1 Engineering	14.1	3.8	6.2	1.8	3.3	3.8	3.5	12.9	28.7	6.6
2 Land and Easements	15.6	3.7	10.4	1.7	2.6	1.0	1.7	3.9	19.8	2.9
3 Environmental Studies and Mitigation	15.5	3.7	10.3	1.7	2.5	1.0	1.7	3.9	19.4	2.8
4 Interest During Construction	8.1	2.2	3.6	1.0	1.9	2.2	2.0	7.3	16.4	3.8
Total Other Cost	53.2	13.4	30.4	6.3	10.3	7.9	8.9	28.0	84.4	16.1
ANNUAL COSTS										
1 Debt Service	6.3	1.9	3.9	0.9	1.6	1.5	1.5	4.9	13.0	2.8
2 Operation and Maintenance	0.6	0.2	0.2	0.1	0.1	0.1	0.1	0.5	1.3	0.2
3 Pumping Energy Costs	-	-	-	-	-	-	-	-	-	-
4 Purchase Water Cost	<i>not incl.</i>	<i>not incl.</i>	<i>not incl.</i>	<i>not incl.</i>	<i>not incl.</i>	<i>not incl.</i>	<i>not incl.</i>	<i>not incl.</i>	<i>not incl.</i>	<i>not incl.</i>
Total Annual Cost	6.9	2.1	4.1	1.0	1.7	1.6	1.6	5.4	14.3	3.0

^a Values current as of 2nd Quarter 2007 (HDR Undated).

Pipelines

The physical data of each pipeline element evaluated is summarized in Tables C-5 and C-6.

Table C-5: Summary of selected physical data for pipeline elements: P-1 through P-6.

ELEMENT NO.	P-1	P-2	P-3	P-4	P-5	P-6.1	P-6.2
PIPELINE	Lower Blanco to FRS	Canyon Lake to Cibolo	Lake Dunlap to Cibolo	Lake Dunlap to San Geronimo	Lake Dunlap to Lower Verde	Guadalupe River to Medina Lake Tributary	Medina Lake to San Geronimo
DIMENSIONS							
Length (miles)	6.2	17.1	22.5	65.0	95.3	9.2	8.3
Diameter (inches)	24	108	108	108	108	72	72
No. of Lines	1	2	2	2	2	1	2
Total Flow (gpm)	7,796	297,561	297,561	297,561	297,561	111,585	223,170
Total Flow (acre-ft/mo)	1,048	40,000	40,000	40,000	40,000	15,000	30,000
ELEVATION							
Intake (ft msl)	690	980	530	530	530	1,390	1,050
Discharge (ft msl)	780	1,000	913	1,095	1,020	1,900	1,140
Maximum for Pipe (ft msl)	900	1,388	1,030	1,312	1,312	2,005	1,269
WELL FIELD							
No. of Wells	-	-	-	-	-	-	-
Individual Well Capacity (gpm)	-	-	-	-	-	-	-
Collection Manifold (total linear ft)	-	-	-	-	-	-	-

Table C-6: Summary of selected physical data for pipeline elements: P-7 through P-10

ELEMENT NO.	Pw-7	P-8	Pw-9	P-10a	P-10b
PIPELINE	Medina Well Field to Seco Creek	Seco Creek to Upper Seco Creek	Uvalde Well Field to Dry Frio	Indian Creek to Dry Frio	Indian Creek to Dry Frio
DIMENSIONS					
Length (miles)	29.8	7.2	11.3	18.3	18.3
Diameter (inches)	72	78	54	36	108
No. of Lines	1	1	1	1	1
Total Flow (gpm)	66,000	74,390	36,000	14,878	148,780
Total Flow (acre-ft/mo)	8,136	10,000	4,268	2,000	20,000
ELEVATION					
Intake (ft msl)	850	1284	960	950	950
Discharge (ft msl)	1220	1450	1140	1050	1050
Maximum for Pipe (ft msl)	1220	1450	1210	1250	1250
WELL FIELD					
No. of Wells	33	-	20	-	-
Individual Well Capacity (gpm)	2,000	-	1,800	-	-
Collection Manifold (total linear ft)	33,000	-	21,000	-	-

COST ESTIMATES

Estimated cost data for each pipeline element are presented in Tables C-7 and C-8.

Table C-7: Cost estimate summary for pipeline elements: P-1 through P-6.

ELEMENT NO.	P-1	P-2	P-3	P-4	P-5	P-6.1	P-6.2
PIPELINE	Lower Blanco to FRS	Canyon Lake to Cibolo	Lake Dunlap to Cibolo	Lake Dunlap to San Geronimo	Lake Dunlap to Lower Verde	Guadalupe River to Medina Lake Tributary	Medina Lake to San Geronimo
ESTIMATED COST (millions of dollars ^a)							
CAPITAL COSTS							
1 Pump Stations	6.0	103.5	75.0	217.5	204.5	46.5	46.6
2 Pipelines	4.8	128.5	411.7	1,306.3	1,762.1	31.4	55.9
3 Water Treatment Plants	-	-	-	-	-	-	-
4 Water Storage Tanks	-	9.8	19.6	29.4	49.0	3.8	-
5 Off Channel Reservoir	-	-	-	-	-	-	-
6 Well Fields (Irrigation)	-	-	-	-	-	-	-
7 Dams and Reservoirs	-	-	-	-	-	-	-
8 Relocations	-	-	-	-	-	-	-
9 Water Distribution System Improvements	-	-	-	-	-	-	-
10 Other Items	-	-	-	-	-	-	-
Total Capital Cost	10.8	241.8	506.4	1,553.2	2,015.7	81.7	102.4
OTHER COSTS							
1 Engineering	3.5	78.2	156.7	478.3	617.4	27.0	33.1
2 Land and Easements	0.2	1.3	1.7	4.3	6.1	0.5	0.5
3 Environmental Studies and Mitigation	0.2	0.7	1.0	2.1	2.9	0.3	0.2
4 Interest During Construction	2.2	48.4	101.3	310.6	403.1	16.3	20.5
Total Other Cost	6.1	128.6	260.6	795.3	1,029.5	44.1	54.3
ANNUAL COSTS							
1 Debt Service	1.2	32.3	66.9	204.7	265.5	11.0	13.7
2 Operation and Maintenance	0.1	4.0	6.5	18.8	23.2	1.5	1.7
3 Pumping Energy Costs	0.8	41.2	29.4	88.2	77.6	17.6	17.6
4 Purchase Water Cost	<i>n/a</i>	<i>n/a</i>	<i>n/a</i>	<i>n/a</i>	<i>n/a</i>	<i>n/a</i>	<i>n/a</i>
Total Annual Cost	2.1	77.4	102.7	311.7	366.3	30.1	33.0

^a Values current as of 2nd Quarter 2007 (HDR Undated).

Table C-8: Cost estimate summary for pipeline elements: P-7 through P-10.

ELEMENT NO.	Pw-7	P-8	Pw-9	P-10a	P-10b
PIPELINE	Medina Well Field to Seco Creek	Seco Creek to Upper Seco Creek	Uvalde Well Field to Dry Frio	Indian Creek to Dry Frio	Indian Creek to Dry Frio
ESTIMATED COST (millions of dollars^a)					
CAPITAL COSTS					
1 Pump Stations	31.1	14.2	12.8	10.3	37.5
2 Pipelines	99.5	26.5	24.1	21.5	127.8
3 Water Treatment Plants	-	-	-	-	-
4 Water Storage Tanks	5.6	2.8	2.1	1.2	5.6
5 Off Channel Reservoir	-	-	-	-	-
6 Well Fields (Irrigation)	23.1	-	14.5	-	-
7 Dams and Reservoirs	-	-	-	-	-
8 Relocations	-	-	-	-	-
9 Water Distribution System Improvements	-	-	-	-	-
10 Other Items	-	-	-	-	-
Total Capital Cost	159.2	43.4	53.4	32.9	170.8
OTHER COSTS					
1 Engineering	50.8	13.9	17.5	10.4	53.4
2 Land and Easements	1.7	0.3	0.8	0.7	0.9
3 Environmental Studies and Mitigation	0.9	0.2	0.4	0.5	0.5
4 Interest During Construction	31.8	8.7	10.7	6.6	34.2
Total Other Cost	85.2	23.1	29.3	18.2	88.9
ANNUAL COSTS					
1 Debt Service	21.3	5.8	7.2	4.5	22.6
2 Operation and Maintenance	2.1	0.6	0.7	0.5	2.3
3 Pumping Energy Costs	16.6	4.1	8.2	2.4	17.6
4 Purchase Water Cost	12.4	<i>n/a</i>	6.5	<i>n/a</i>	<i>n/a</i>
Total Annual Cost	52.4	10.6	22.7	7.3	42.5

^a Values current as of 2nd Quarter 2007 (HDR Undated).

LOCATION

The location of each recharge structure and pipeline element and is presented in Figures C-3 through C-13.

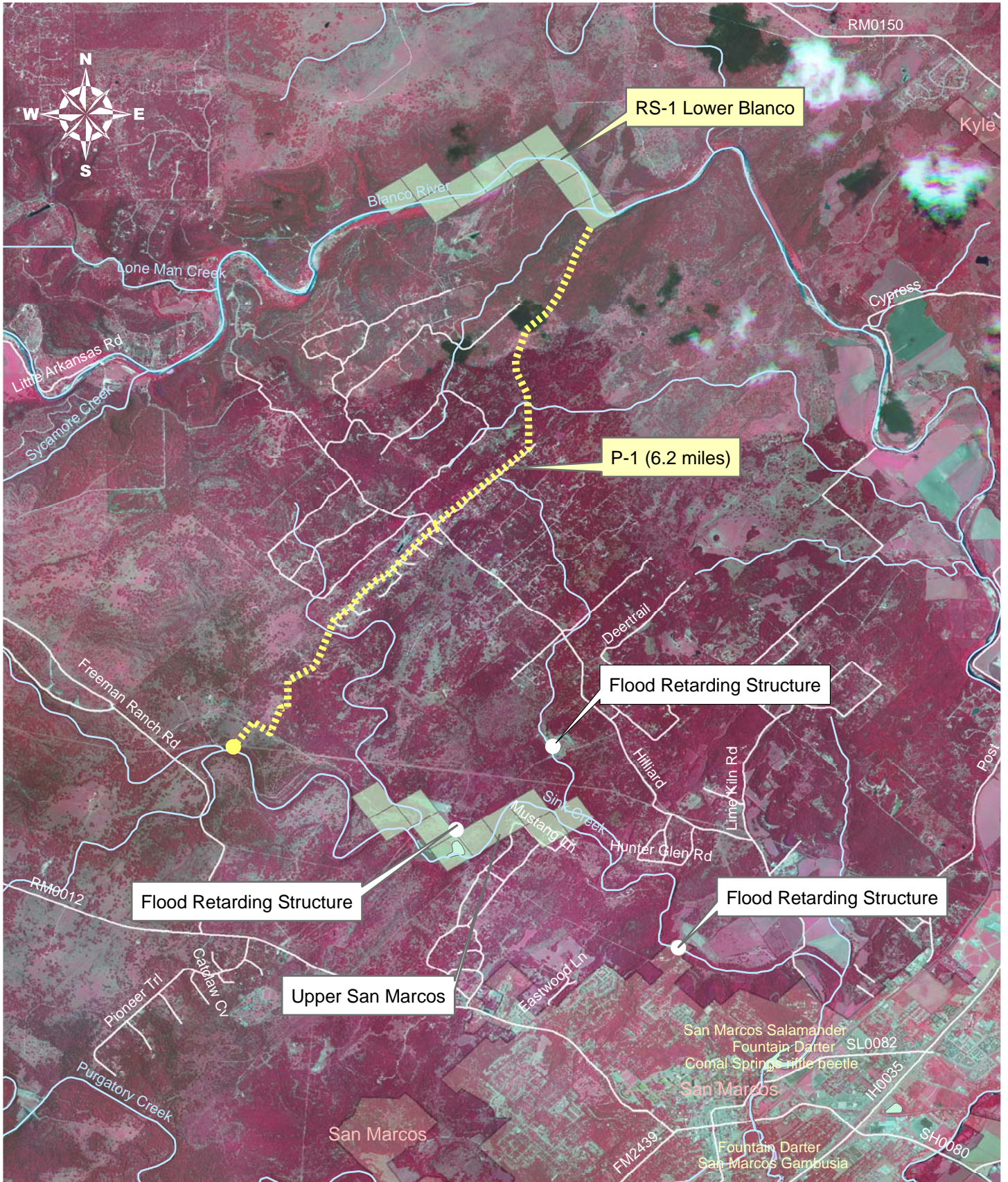

Edwards Aquifer Recharge and Recirculation Project

Figure C-3

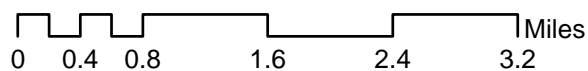

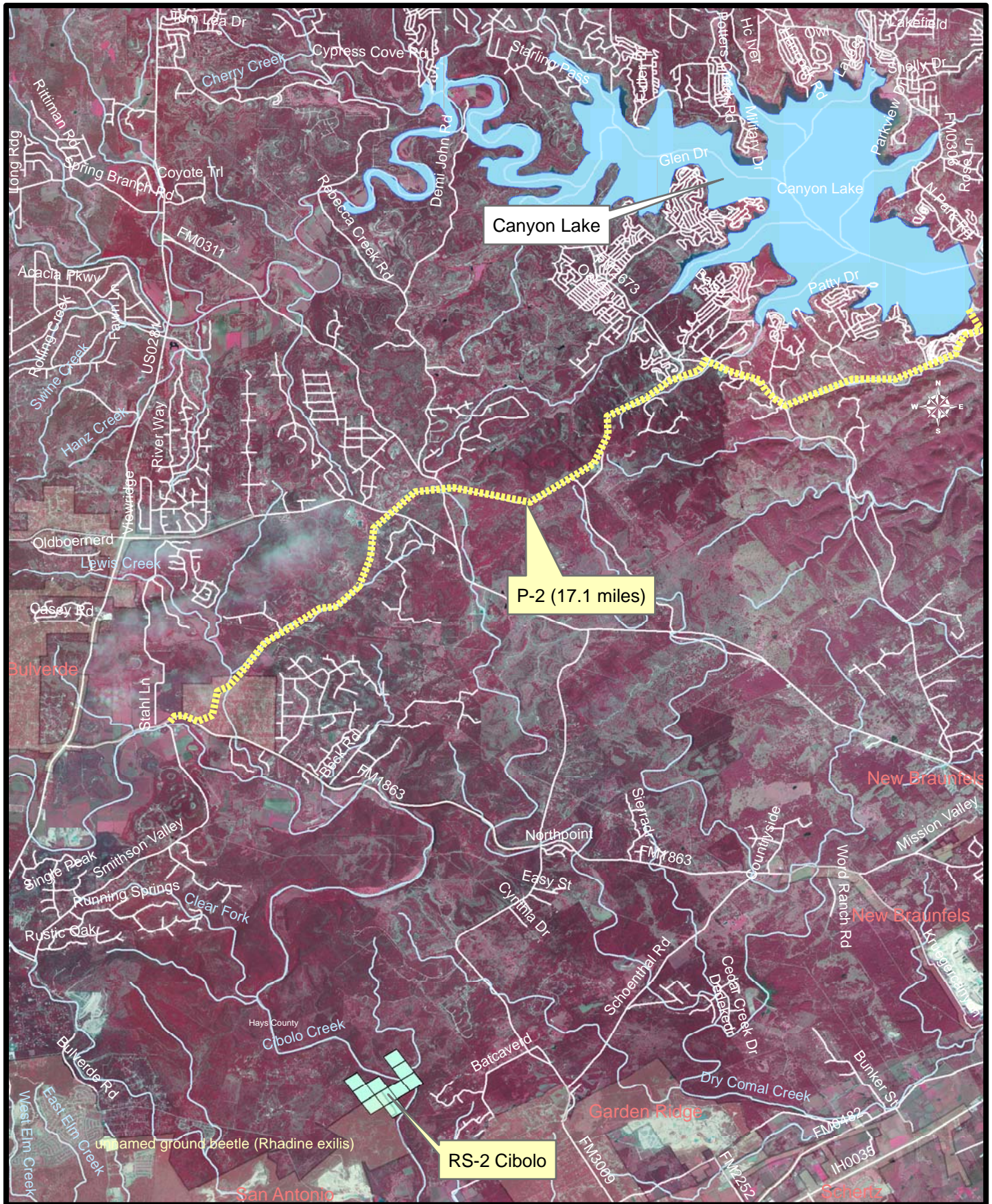

Edwards Aquifer Recharge and Recirculation Project

Figure C-4

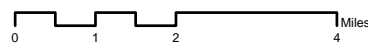

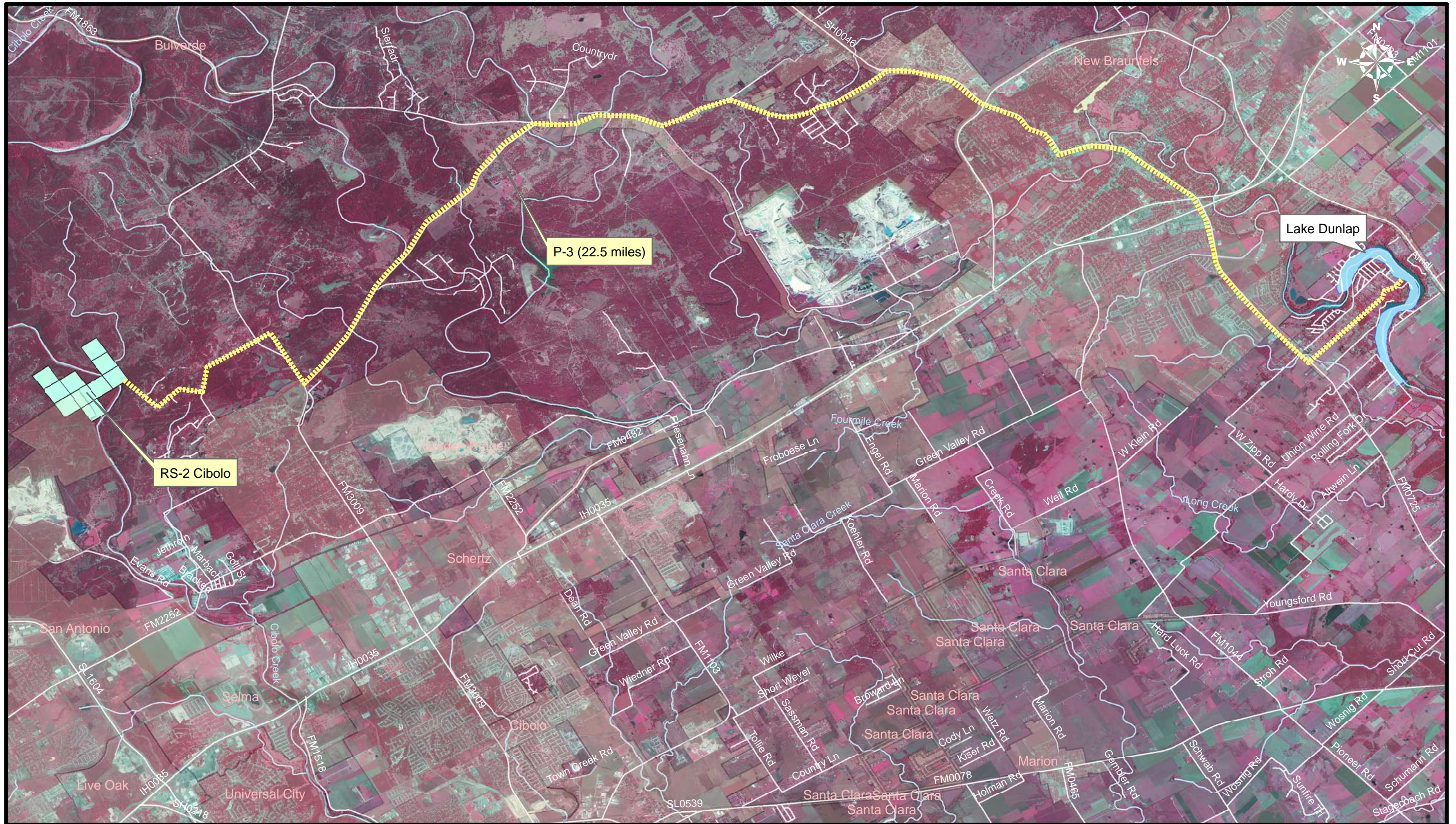

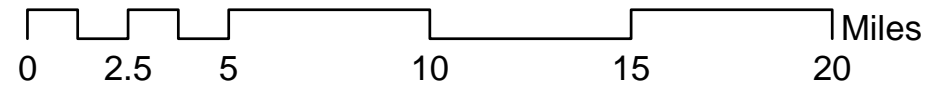

Edwards Aquifer Recharge and Recirculation Project

Figure C-7

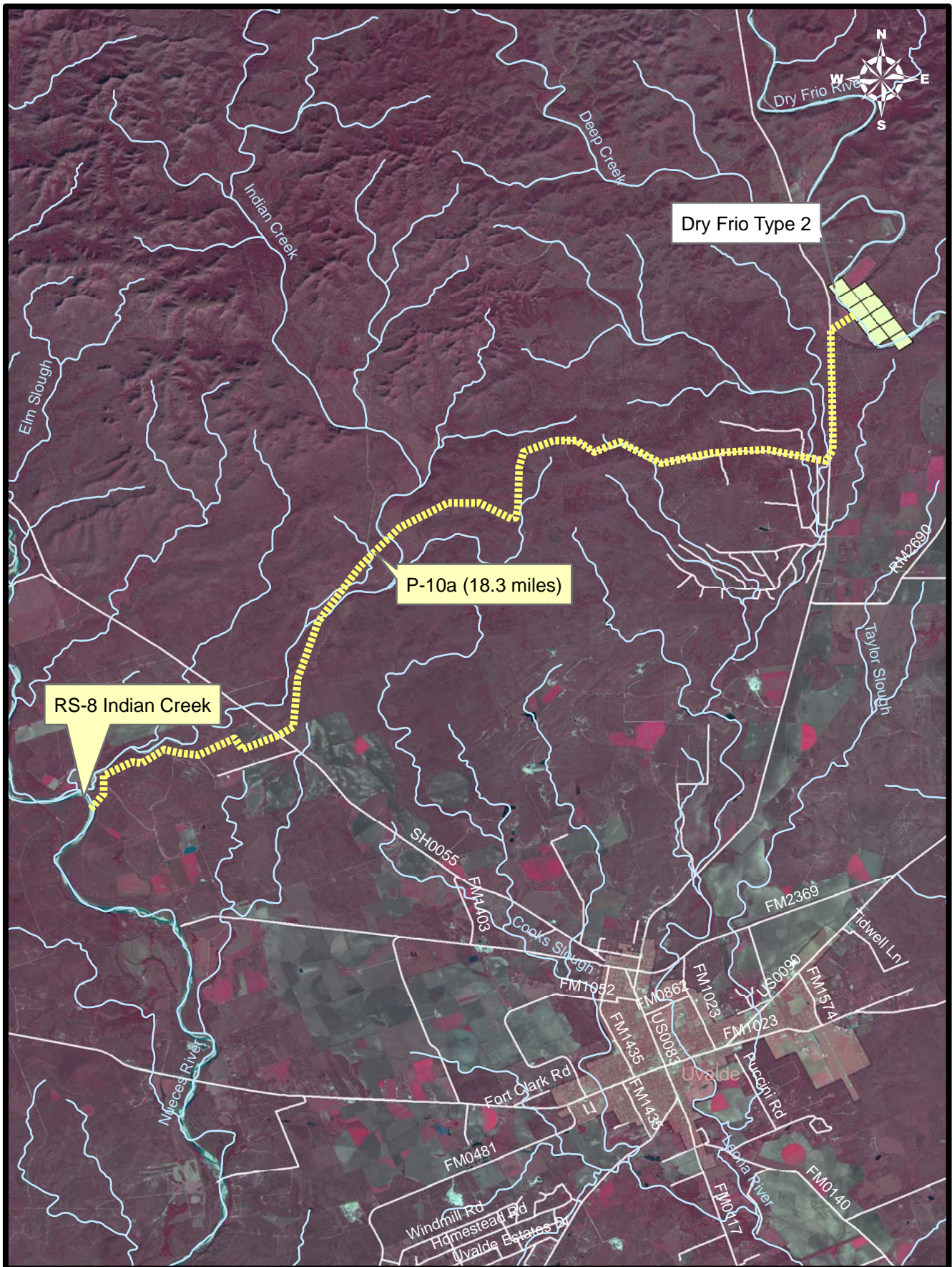

Edwards Aquifer Recharge and Recirculation Project

Figure C-8

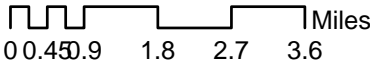

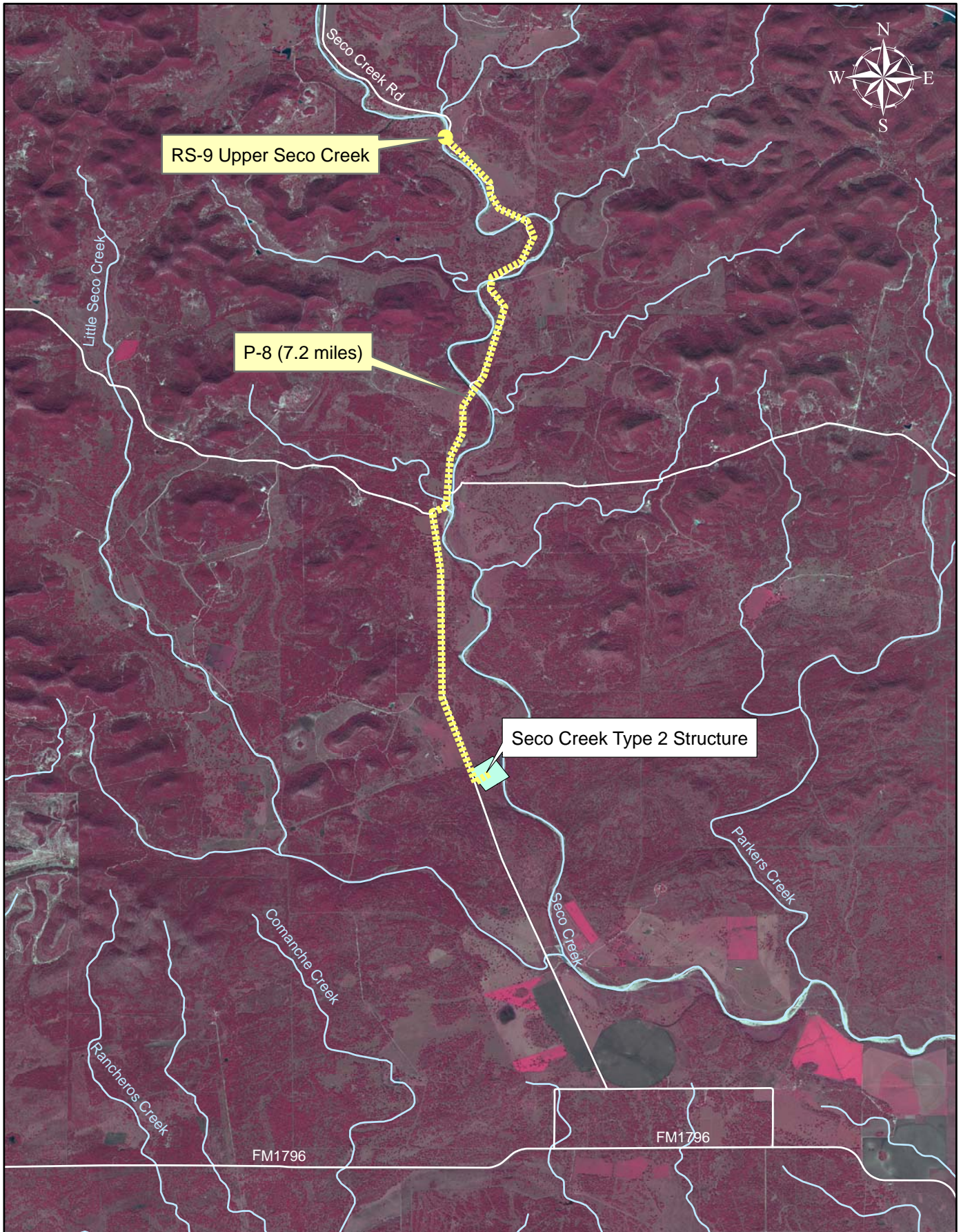

Edwards Aquifer Recharge and Recirculation Project

Figure C-9

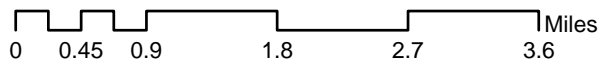

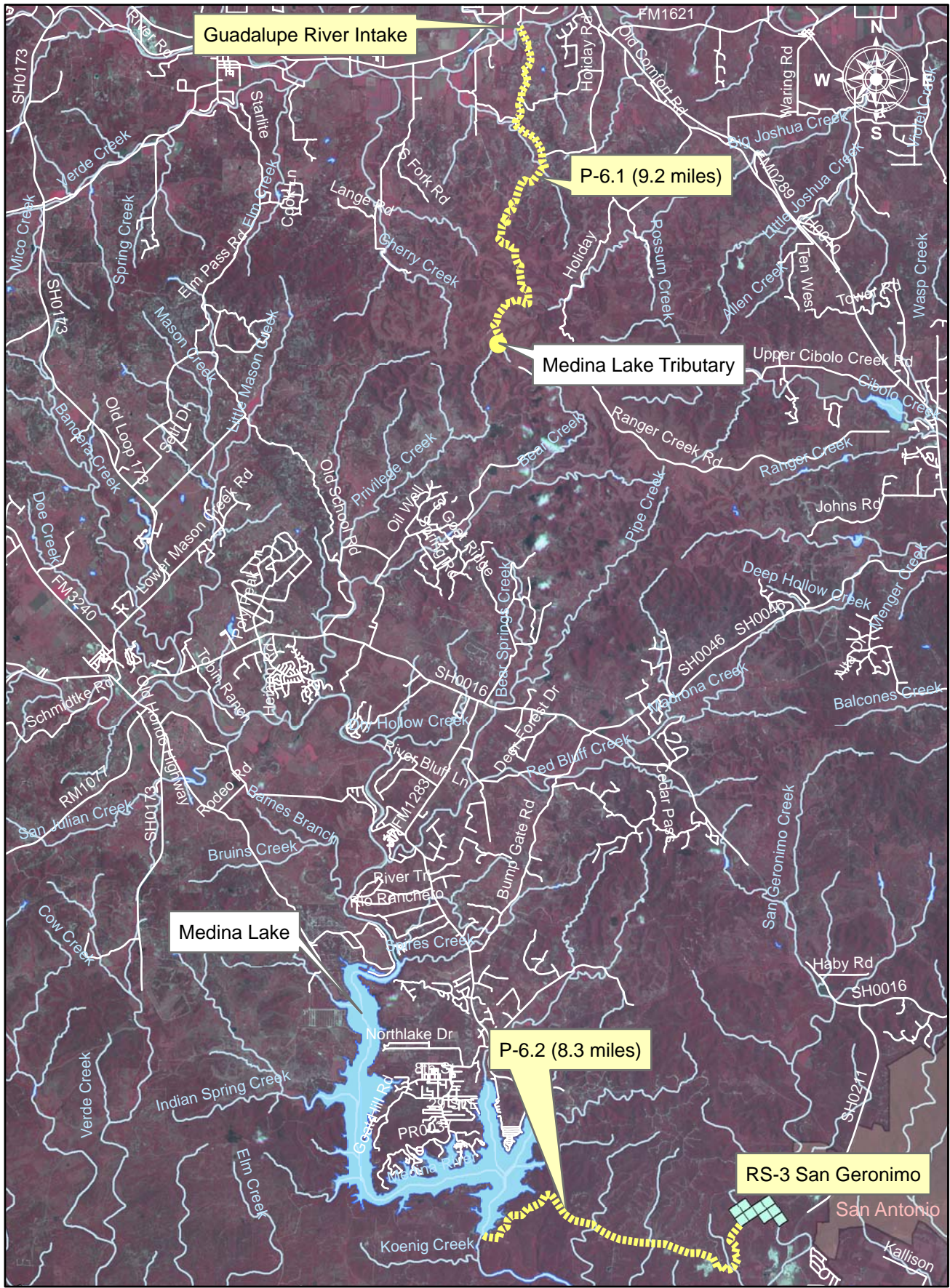

0.25 Miles
11.52

Edwards Aquifer Recharge and Recirculation Project

Figure C-10

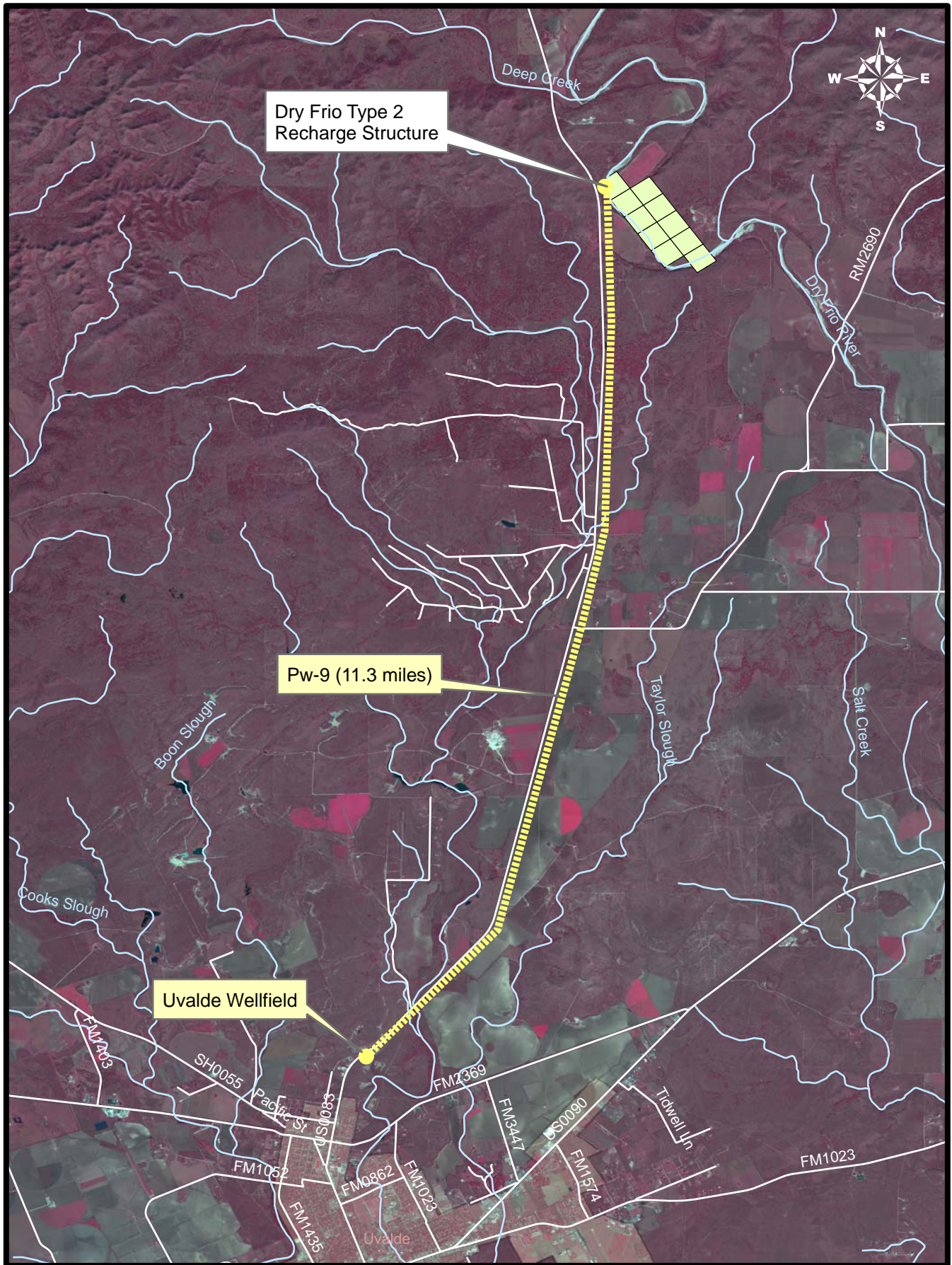

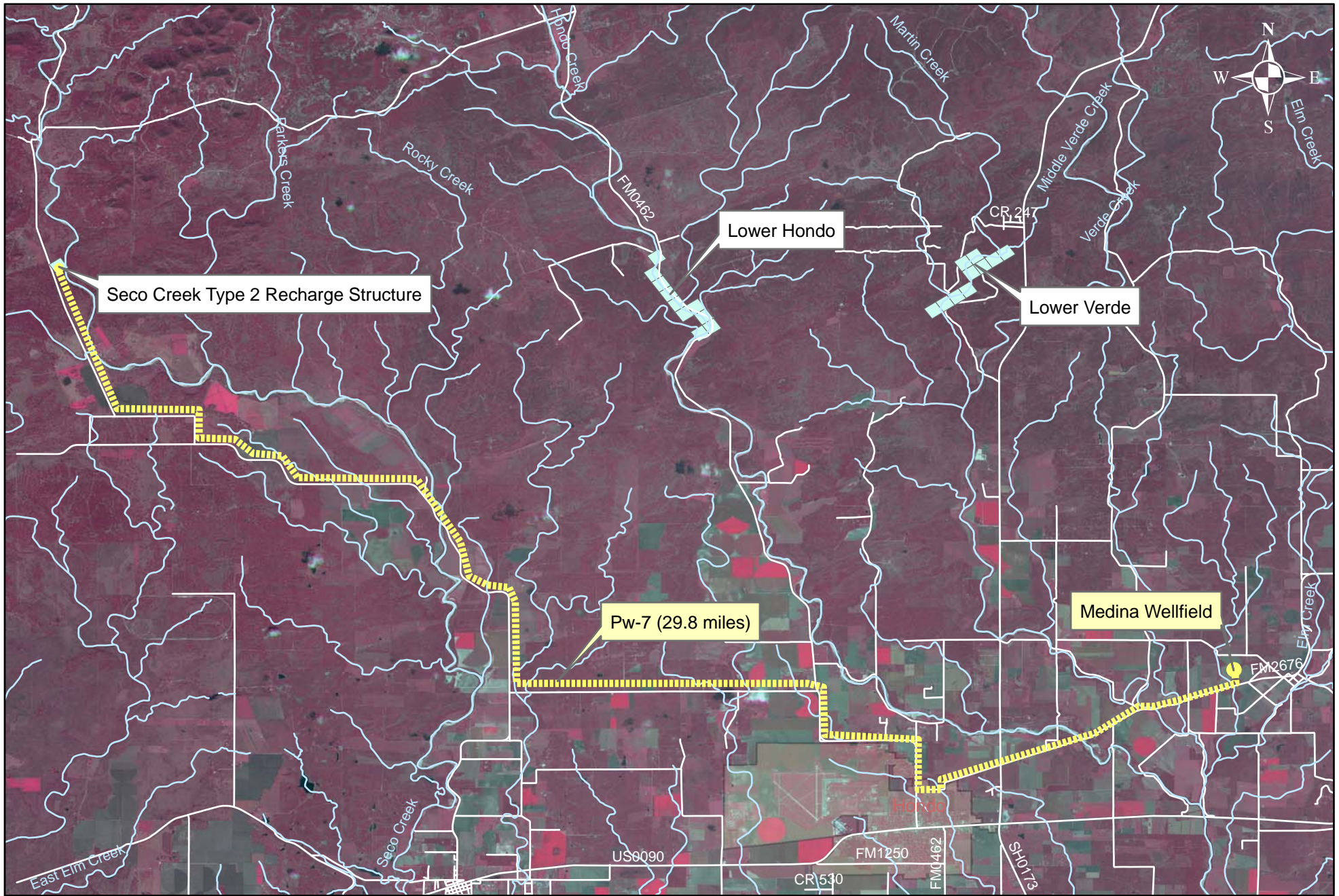

PROFILES

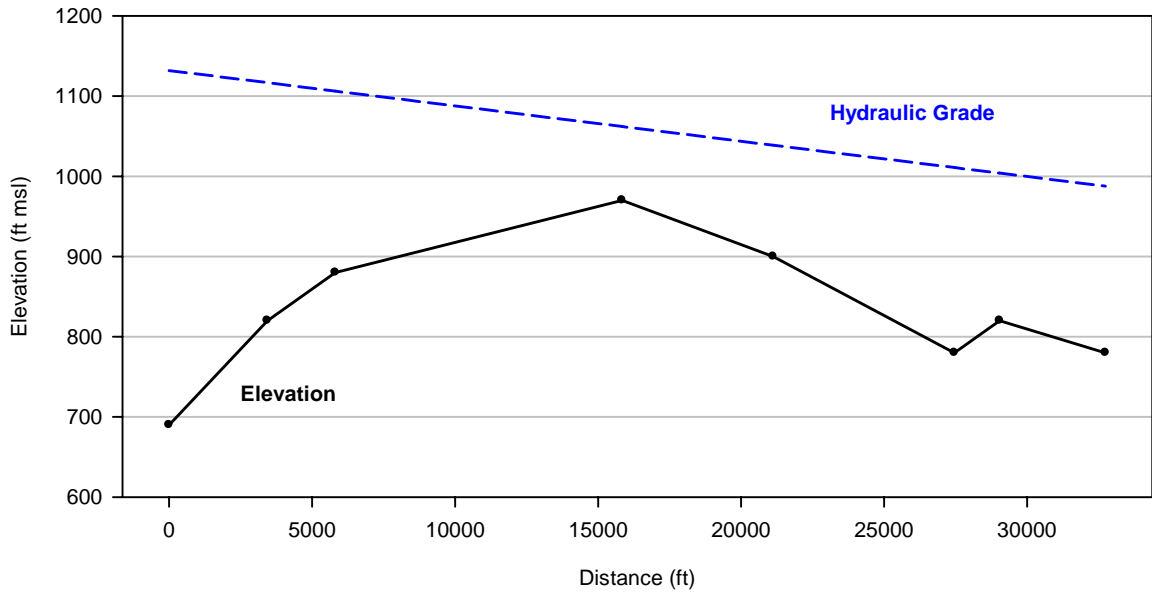

Figure C-13: Profile for P-1 (Lower Blanco to flood retardation structure).

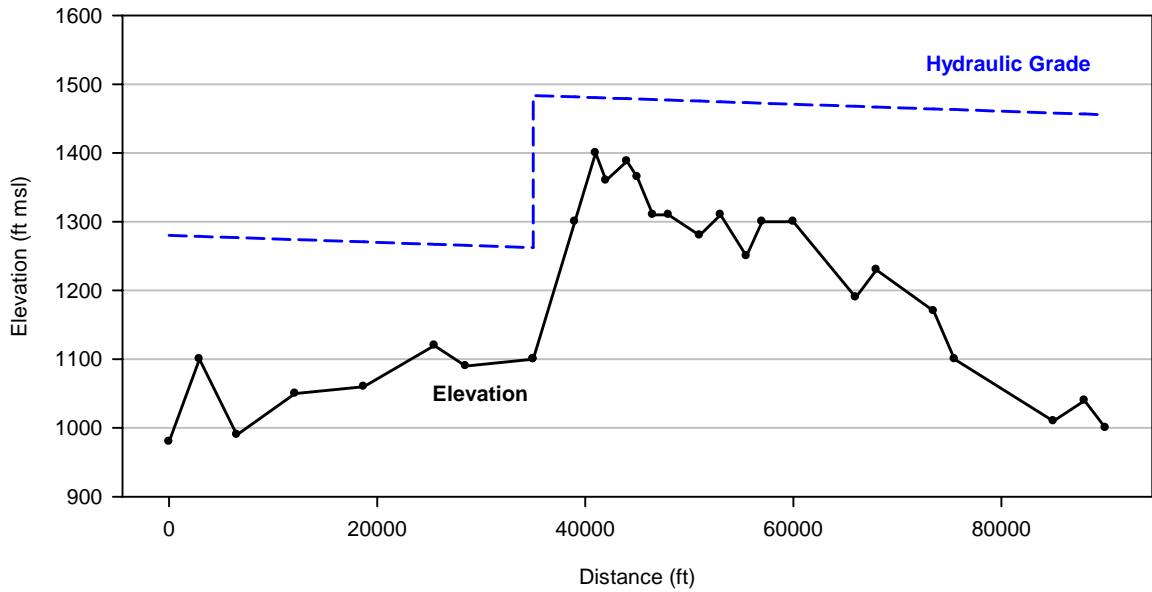

Figure C-14: Profile for P-2 (Canyon Lake to Cibolo).

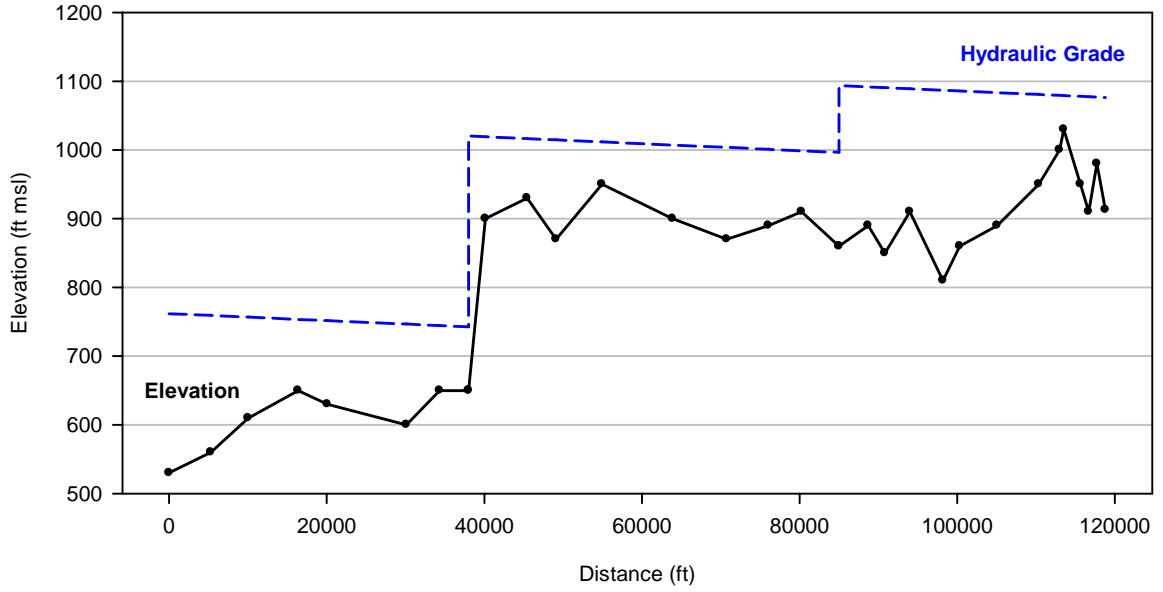

Figure C-15: Profile for P-3 (Lake Dunlap to Cibolo).

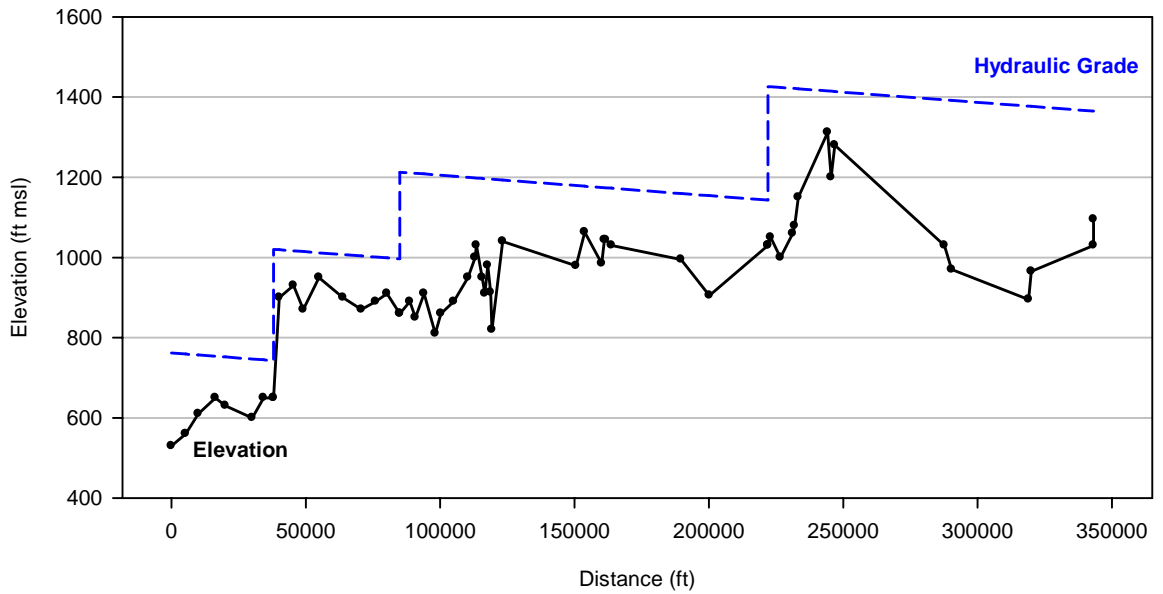

Figure C-16: Profile for P-4 (Lake Dunlap to San Geronimo).

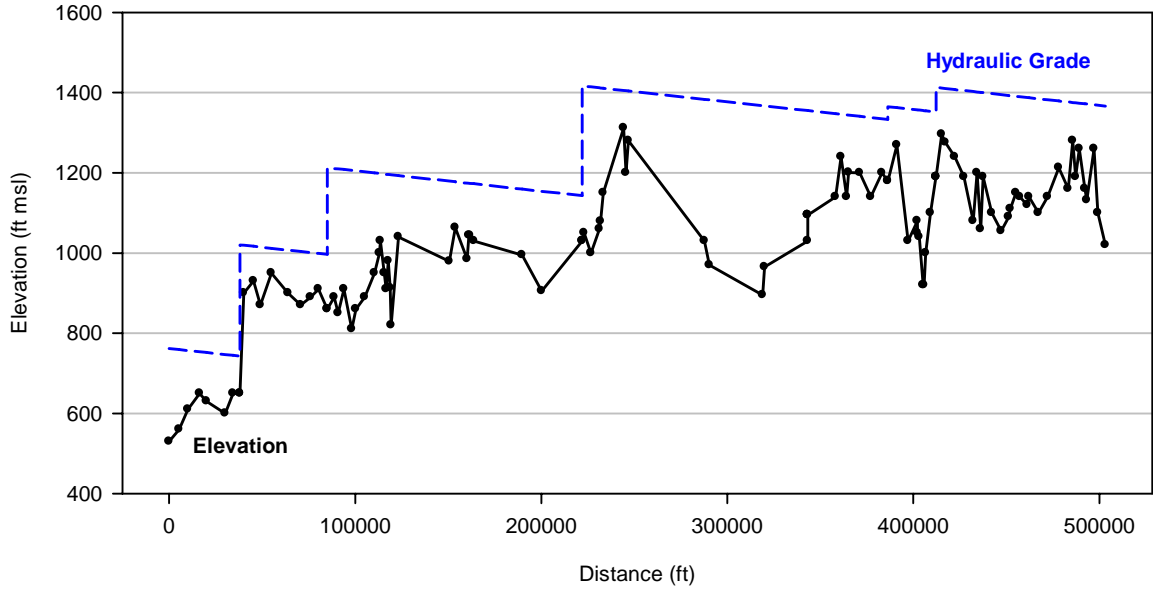

Figure C-17: Profile for P-5 (Lake Dunlap to Lower Verde).

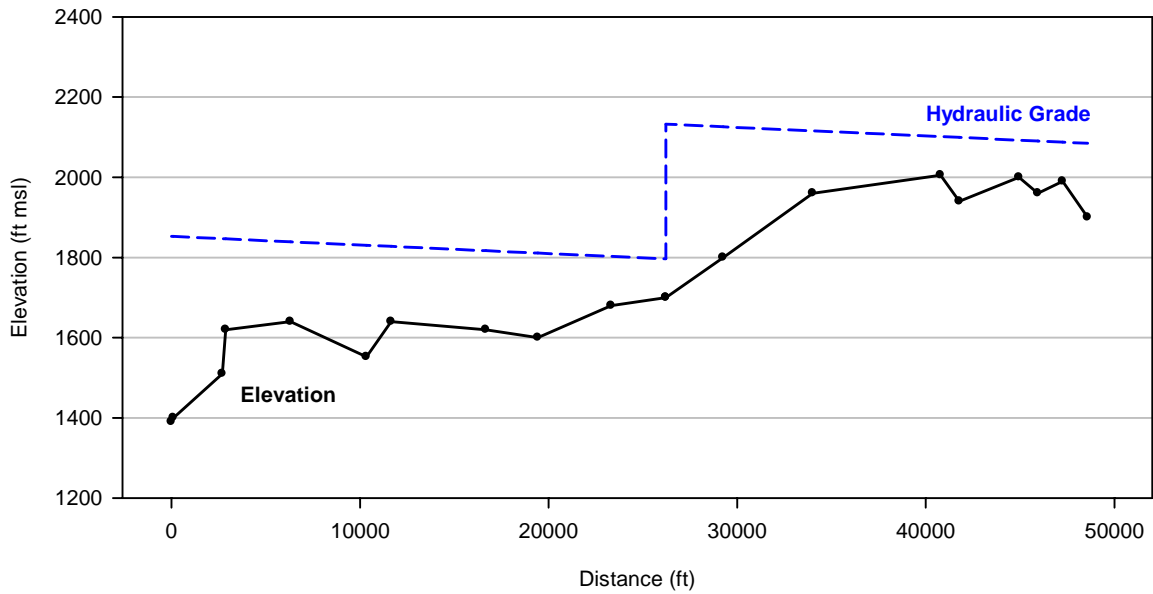

Figure C-18: Profile for P-6.1 (Guadalupe River to Lake Medina Tributary).

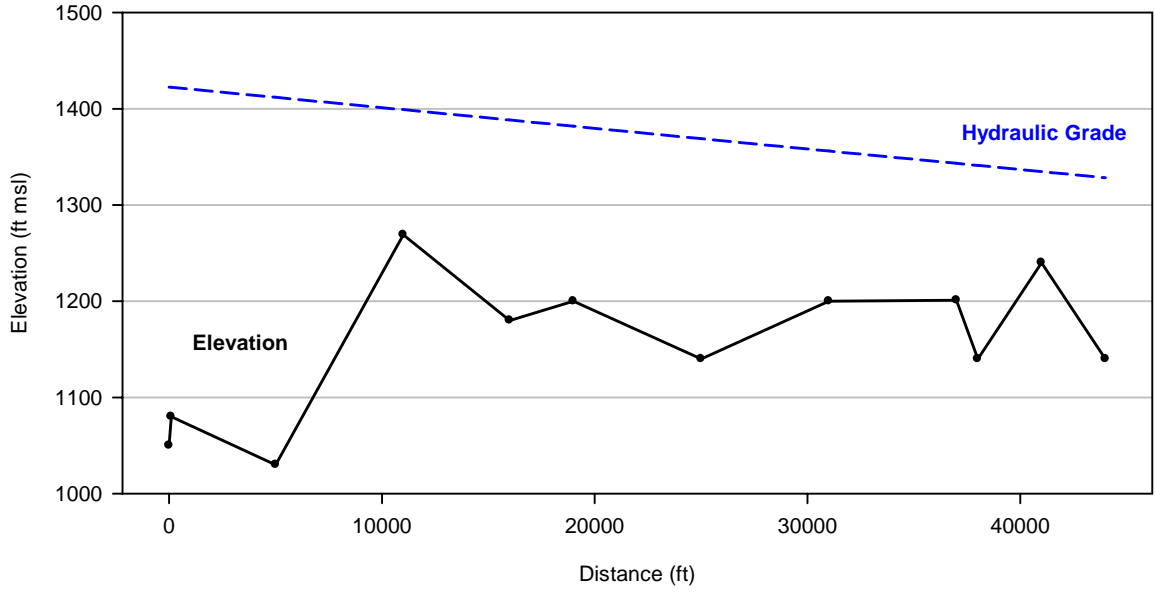

Figure C-19: Profile for P-6.2 (Medina Lake to San Geronimo).

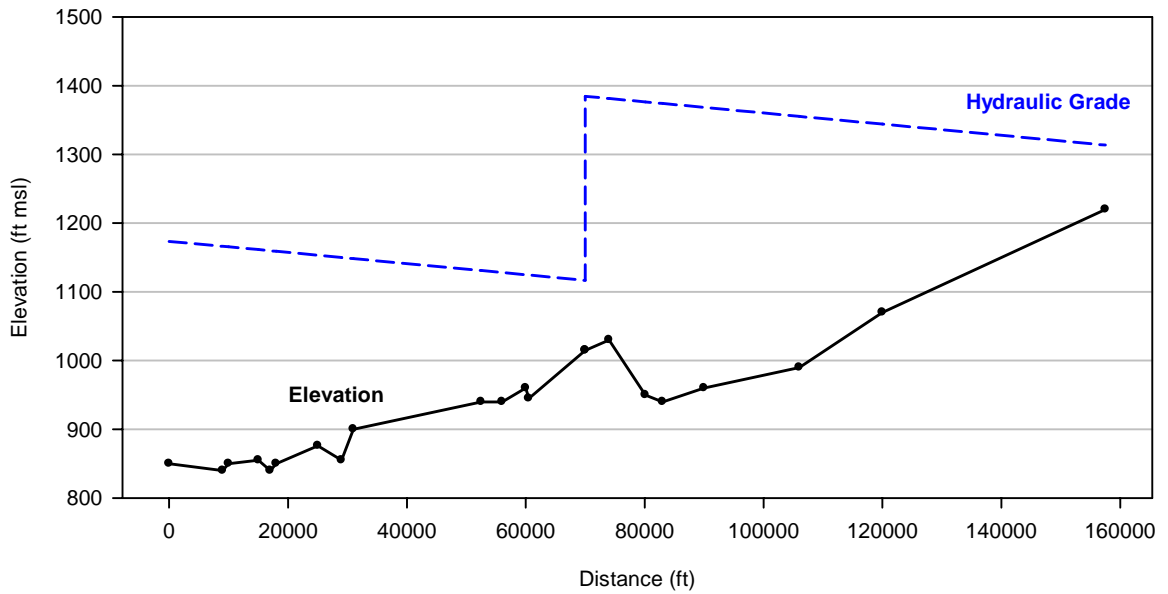

Figure C-20: Profile for Pw-7 (Medina Well Field to Seco Creek Type 2).

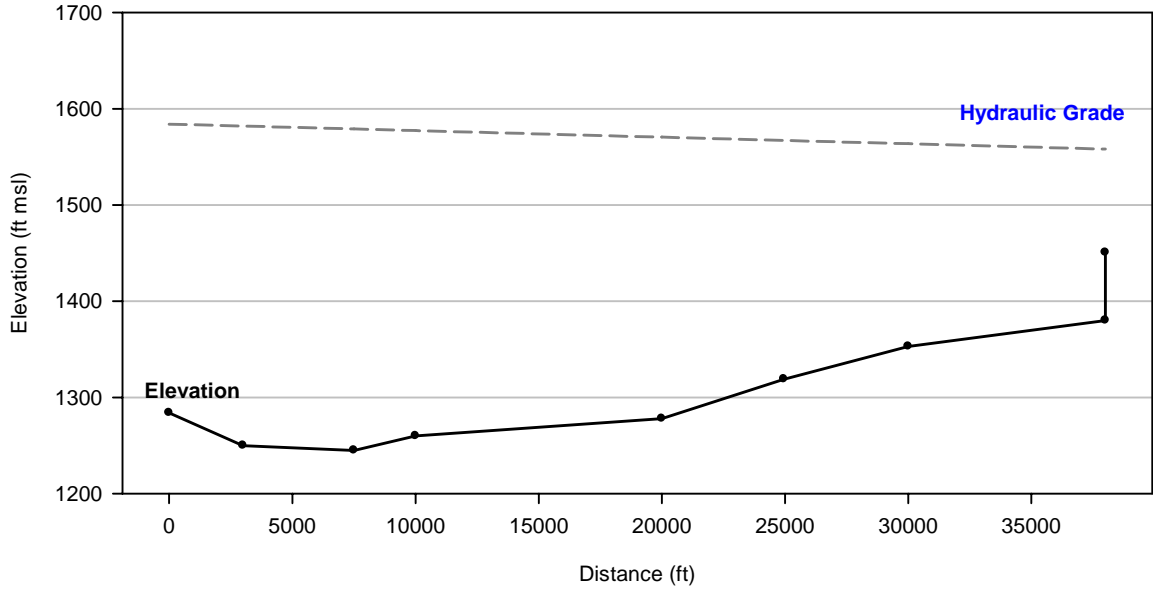

Figure C-21: Profile for P-8 (Seco Creek Type 2 to Upper Seco Creek).

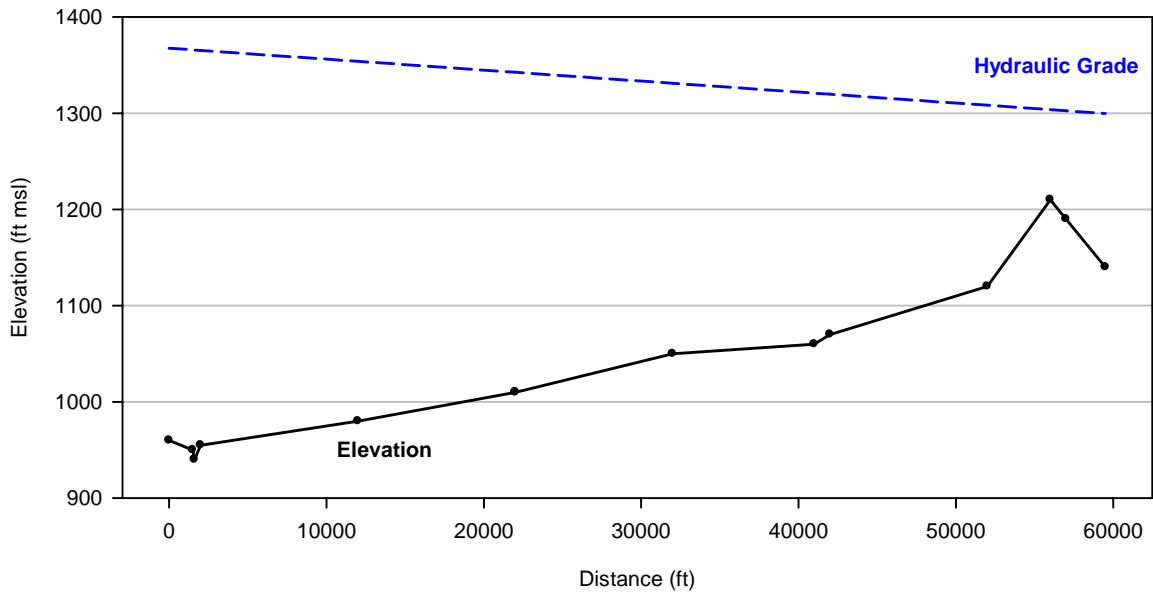

Figure C-22: Profile for Pw-9 (Seco Creek Type 2 to Upper Seco Creek).

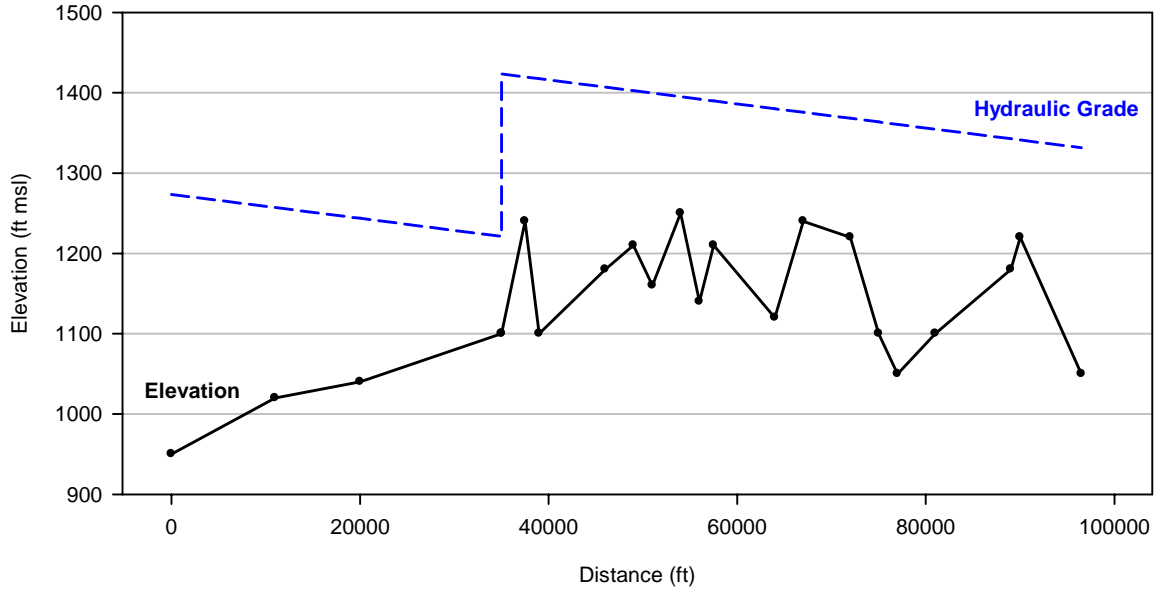

Figure C-23: Profile for P-10a (Indian Creek to Dry Frio Type 2).

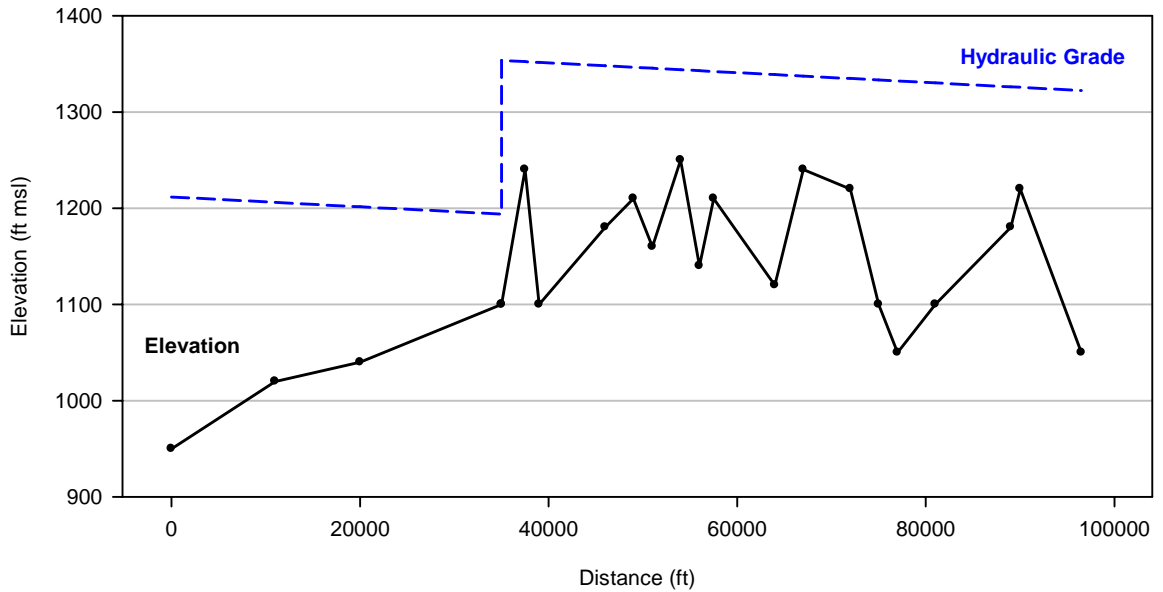

Figure C-24: Profile for P-10b (Indian Creek to Dry Frio Type 2).

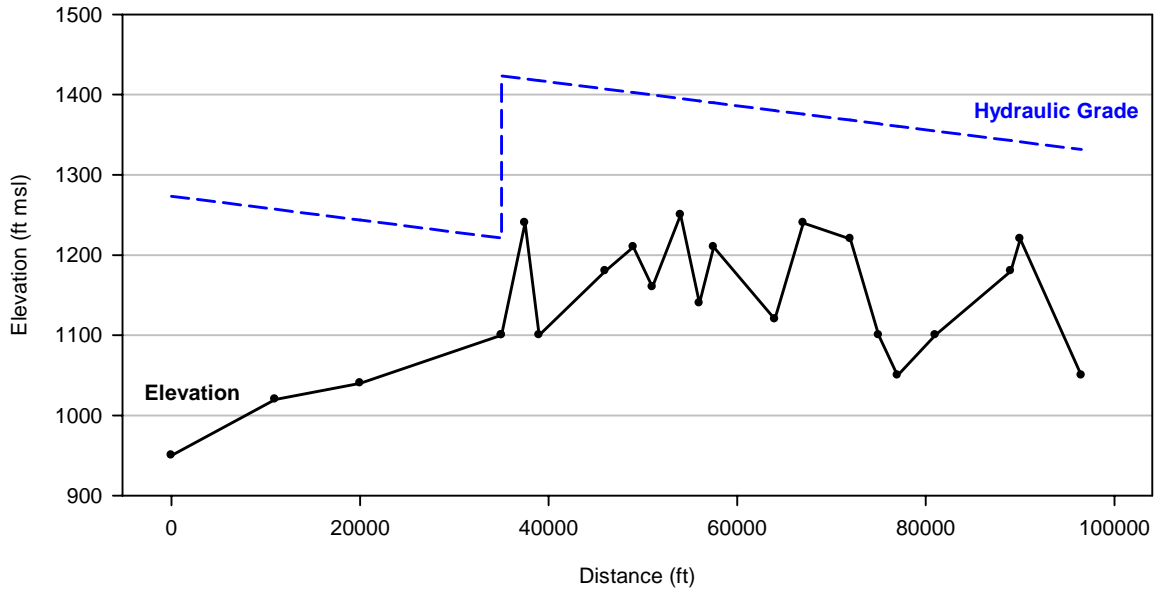

Figure C-25: Profile for P-10a (Indian Creek to Dry Frio Type 2).

Planning Considerations

The following section provides a summary discussion of engineering and cost considerations relevant to implementing the aquifer recharge and recirculation alternatives evaluated.

Engineering Approach

Project implementation will require further studies for percolation rates, geology, habitat, environmental issues, power costs, and land cost considerations. Alternate methods of routing pipelines may change the cost significantly based on the variability of land costs across the region, and variability in environmental and ecological issues. The project should begin with preliminary engineering studies, followed by final engineering, and permitting, followed by construction phases. The permitting stage will be an extensive phase of the program. Additionally, the project will require operational studies to insure the projects are transporting water at optimum time periods.

Cost Assumptions

PURCHASED WATER COSTS

Surface Water

Given the uncertainty in determining reliable cost estimates for acquisition of surface water rights, no value for "Purchased Water Cost" was included in the present cost analysis. It is expected that only unappropriated surface water rights would be included in the aquifer recharge and recirculation project under evaluation. Costs for acquiring a new (unappropriated) surface water right in Texas are difficult to assess because it depends on how much diversion authority is being requested and how much opposition there might be to the new appropriation (Brandes 2008). First, there would be costs associated with preparation of an application (perhaps \$2,000 to \$5,000 unless performed in-house). Next, there would be fees due to the Texas Commission on Environmental Quality, which are based on \$1.00 per acre-foot of maximum amount of water being appropriated plus probably about \$500 for other costs. If the application is protested, then there will be legal fees, expert fees, and possibly costs for paying an existing water right holder for the right to affect his right. A State Office of Administrative Hearings public hearing would be likely with testimony and even court costs if the agency decision is appealed. All totaled, these costs could range from \$5,000 to over \$200,000 per application.

Groundwater

The present market for selling unused rights groundwater rights in the Edwards Aquifer is one-time payment of about \$5,000 per acre-foot (Ilgnier 2008; Thompson 2008). For a 10-year lease of groundwater rights, a current estimate is approximately \$127.50 per acre-foot per year was provided by the San Antonio Water System based on their recent experiences (Thompson 2008). However, it is unlikely that many (or any) of the unused permits would be permanently purchased to implement the aquifer recharge and recirculation project. Rather, it is considered more likely that the necessary groundwater rights would be leased (probably

irrigation rights during a wet year). Such leasing costs would be negotiated on a case-by-case basis, and the terms and costs are not presently known.

Environmental Issues

The Texas Hill Country is a diverse region of Texas dominated by the geologic outcrop of the Edwards Balcones Fault Zone. Upland areas are characterized by dry limestone slopes of cedar and scrub oak, while the stream and river lowlands are dominated by cypress riparian reaches, diverse thickets, and shady hardwood bottomlands. Edged by canyon lands are intersected by creeks, and these rocky hills support an abundance of trees, shrubs, and vines that provide food and cover for wildlife.

Extensive environmental reviews have been conducted for many of the recharge structure and pipeline elements addressed in the present work (see especially HDR 1998 and HDR 2001). A general discussion follows of the types of environmental issues and requirements that should be anticipated prior to implementing these elements. The cost estimates for each element provides for these types of environmental review activities.

STUDY REQUIREMENTS

Bay and Estuary Inflow

Surface water in the springs, streams, and rivers of the Texas Hill Country contributes to the flow of several major Texas rivers, including the Colorado, Guadalupe, San Antonio, and Nueces. Each of these river systems provide seasonal freshwater influences critical to the health and productivity of coastal bays and estuaries. Alterations to this flow regime (i.e., magnitude, duration, timing, and frequency) may have negative consequences to estuarine resources. Studies evaluating the impact of surface flow retention and redirection projects on freshwater inflows to bays and estuaries in context to historic conditions may be necessary to determine the extent of such impacts.

Endangered Species

The overall planning area is rich in species diversity and home to numerous Federal listed species and State species of concern. These protected species fall generally within several broad categories: 1) birds (migratory songbirds, shorebirds, and raptors), 2) karst invertebrates, 3) spring-supported fish and amphibians, 4) spring-supported plants, and 5) upland mammals and reptiles. Comprehensive lists of species occurrence by county is available from the U.S. Fish and Wildlife Service and Texas Parks and Wildlife Department, and have previously been presented for the aquifer recharge and recirculation elements evaluated in this work.

Formal Section 7 consultation for potential impacts to Federally listed species will be required where Federal funding or approval is provided by a Federal agency (e.g., U.S. Army Corps of Engineers under Section 404 of the Clean Water Act). This process will likely require the preparation of a Biological Assessment that evaluates the potential impacts of the proposed project on listed species.

Cultural Resources

Archeological sites within the study area are abundant and generally consist of lithic procurement sites, open camps, shelters, and 19th Century homesteads. For each element,

prior to implementation, it must be determined if any cultural properties are located with the project area by an on-site (Level I) survey. Once identified, any cultural properties would undergo an assessment to determine the significance and potential eligibility for listing in the Register of Historic Places. This assessment may involve field testing. If determined to be eligible, the sites would be mitigated by either avoidance or possibly undergo scientific data recovery.

Karst Geology and Organisms

At least 9,500 caves, sinkholes and springs are known in Texas, distributed in karst regions covering about twenty percent of the state (Elliott 2008). Karst is a terrain formed by the dissolution of bedrock, and generally is characterized by sinkholes and caves that channel water underground. Texas caves and karst aquifers are important economic, scientific, and recreational resources.

Texas caves are important resources for several reasons. Hundreds of ancient species, specially adapted to an energy-efficient life in permanent darkness, are scattered through the karst of Central Texas (Elliott 2008). Cave-adapted salamanders, catfish, shrimps, isopods, amphipods, snails, spiders, harvestmen, pseudoscorpions, beetles, millipedes, centipedes, and other types have been described. Most of these occur in the Balcones Fault Zone, where geologic isolation in faulted, river-dissected karst blocks has resulted in an evolutionary history like that of an archipelago. Some of these species are endangered by land development, overuse of groundwater, pollution, and pests such as the red imported fire ant. Other major cave residents included large populations of resident and migratory bats. Finally, many Texas caves contain fossils of extinct vertebrate animals and evidences of human use for shelter and food collection. Studies that evaluate the impact of enhanced recharge into the limestone faults, sinkholes, and fractures associated with these cave and karst resources should be anticipated.

Other Environmental

Many other environmentally sensitive resources in the overall study area may require specialized study. These resources include riparian and bottomland hardwoods associated with stream and rivers, mature upland forests and scrublands, and perennial and intermittent riverine wetlands. In some cases (e.g., wetlands), such studies will be part of a permitting process (e.g., Section 404 of the Clean Water Act).

Several river systems in the overall planning area have had selected reaches nominated as Ecologically Unique River and Stream Segments nominated by the Texas Parks and Wildlife Department. The types of potential impacts from the recharge structure and pipeline elements evaluated include stream crossings, impoundments, and diversions (reduced flow). Identification of these unique segment designation and studies to determine potential negative impacts should be anticipated prior to project implementation.

PERMITTING REQUIREMENTS

Water Rights and Storage Permit

Permit from TCEQ required for on- and off-channel reservoirs for the storage of surface water. If water storage is in Natural Resources Conservation Service (Soil Conservation Service) reservoir, consent from Soil & Water Conservation District or other sponsor having jurisdiction over the reservoir will also be required. Permit fees depend upon storage capacity and range from \$100 (<100 acre-feet) to \$2,000 (>250,000 acre-feet). Groundwater rights must be secured from the landowner.

Section 10 and 404 Dredge and Fill Permits

Permits required from the US Army Corps of Engineers under the Clean Water Act when physical modification to a watercourse (e.g., stream crossings with pipelines) or its adjacent wetlands is anticipated. The primary purpose of the permit is to regulate the discharge of dredge or fill material into waters of the United States, including special aquatic sites such as wetlands. For a 404 permit, a 401 water quality certification is also required from TCEQ that the proposed discharge will comply with state water quality standards. The Corps can authorize activities by a standard individual permit, letter-of-permission, nationwide permit, or regional permit.

Sand, Gravel, and Marl Removal Permits

Removal of sand or gravel in Texas must be permitted by the General Land Office and Texas Parks and Wildlife Department. The application for an individual permit shall set forth the proposed location, quantities, kinds of materials to be removed, equipment to be used, period of time, names of alongshore property owners on both sides of the waterway for one-half mile both upstream and downstream of the proposed operation, and other information as may be required.

Easement for Use of State-Owned Land

The General Land Office administers State land, including issuing easements for utility projects proposed on state-owned lands. Detailed maps (or plats) are necessary for easement application.

Coastal Coordination Council Review

The Coastal Coordination Council (CCC) oversees implementation of the Texas Coastal Management Program (TCMP), part of the General Land Office. TCMP rules state that actions that may adversely affect coastal natural resource areas, including bays and estuaries, must comply with the goals and policies of TCMP. The CCC is authorized to review actions for consistency (consistency determination) with the goals and policies.

References

- ASFMRA. 2007. Texas Rural Land Value Trends 2007. American Society of Farm Managers and Rural Appraisers, San Antonio, Texas.
- Brandes, Robert, Ph.D., P.E. 2008. TRC, personal communication. September 2008.
- Elliott, William R., Ph.D. 2008. Overview of Texas Caves & Karst. Texas Speleological Survey, Austin, Texas. Available on-line at:
http://www.utexas.edu/tmm/sponsored_sites/tss/cavesandkarst/index.html.
- HDR Engineering Inc. 1991. Nueces River Basin Regional Water Supply Planning Study Phase III—Recharge Enhancement. November 1991.
- HDR Engineering Inc. 1994. Edwards Aquifer Recharge Enhancement Project Phase IVA, Nueces River Basin. June 1994.
- HDR Engineering Inc., 1998. Trans-Texas Water Program, West Central Study Area, Phase II, Edwards Aquifer Recharge Analysis. March 1998.
- HDR Engineering Inc. 2001a. 2001 South Central Texas Regional Water Plan, Volume II—Regional Water Management Alternative Plans. January 2001.
- HDR Engineering Inc. 2001b. 2001 South Central Texas Regional Water Plan, Volume III—Technical Evaluations of Water Supply Options. January 2001.
- HDR Engineering, Inc. Undated. Studies Level Engineering and Costing Methodology for Pipelines, Pump Stations, and Other Facilities. Marked 'Draft' and considered provisional. Courtesy copy provided by Mr. Sam Vaughn.
- Rick Ilgner. 2008. Edwards Aquifer Authority, personal communication. September 2008.
- Texas Water Development Board. 2008. General Guidelines for Regional Water Plan Development (2007-2012). Final Draft dated March 28, 2008. Division of Regional Water and Flood Planning and Natural Resource Information Systems, Texas Water Development Board.
- Thompson, Darren. 2008. San Antonio Water System, personal communication. November 2008.

ANNEX 1:
General Guidelines for
Regional Water Plan
Development (2007-2012)
[Final Draft]

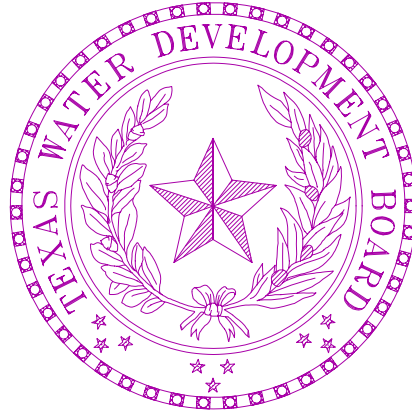

General Guidelines for Regional Water Plan Development (2007-2012)

Prepared by: The Texas Water Development Board

Division of Regional Water and Flood Planning and Natural
Resource Information Systems

28 March 2008

Contents

Background and Purpose.....	3
Section 1.0 Planning Area Description.....	4
Section 2.0 Population and Water Demands.....	4
Section 3.0 Existing Water Supplies.....	5
3.1 Surface Water	6
3.2 Groundwater	9
3.3 Systems	9
3.4 Reuse.....	9
Section 4.0: Water Management Strategies.....	10
4.1 Quantity, Reliability and Financial Costs.....	10
4.1.1 Quantity and Reliability.....	10
4.1.2 Financial Costs.....	10
4.2 Environmental Impacts.....	12
4.3 Alternative Water Management Strategies.....	13
Section 5.0 Impacts of Water Management Strategies on Key Water Quality Parameters in the State and Impacts Moving Water from Agricultural and Rural Areas.....	13
Section 6.0 Water Conservation Practices and Drought Management Recommendations.....	13
Section 7.0 Descriptions of how Regional Water Plans are Consistent with the Long-term Protection of the State’s Water, Agricultural and Natural Resources.....	14
Section 8.0 Unique Stream Segments and Reservoir Sites and Other Legislative Recommendations.....	14
8.1 Unique Stream Segments.....	14
8.2 Unique Reservoir Sites.....	15
8.3 Other Legislative Recommendations.....	15
Section 9.0 Reporting of Financing Mechanisms for Water Management Strategies.....	15
Section 10.0 Adoption of Plan and Public Participation.....	16
Section 11.0 Deliverables.....	16
11.1 Written Reports.....	16
11.2 Regional Water Planning Data Reporting.	16

Background and Purpose

The third round of regional and state water planning as defined by Senate Bill 1 of the 75th Texas Legislature commenced in 2007 and will extend through 2012. Since the third round of planning takes place during an “off-census cycle,” regional water planning groups were in favor of refining the process to allow planning groups greater flexibility in determining the focus of their plans. In addition, both the planning groups and the Texas Water Development Board (TWDB) determined that the current planning cycle would not require complete revisions of regional water plans due to the lack of new population data from the U.S. Census Bureau. In general, regions will focus on specific areas of water demand and water supply availability; evaluations of new water management strategies in response to changed conditions; environmental studies or work to further the implementation of water management strategies recommended in previous plans, reevaluations of population and water demand projections only under the presence of changed conditions; updating the costs of water management strategies, interregional coordination; infrastructure financing surveys and administrative and public participation activities.

The following document summarizes guidelines for developing and/or reevaluating regional water plans for the current planning cycle. Provisions of Title 31 of the Texas Administrative Code (TAC) Chapter 357 serve as the foundation for information in this document. Other referenced sources throughout this document provide additional guidance and clarification including the TWDB document entitled “*Guidelines for Regional Water Planning Data Deliverables*” available at the TWDB’s website, which contains important supplementary information regarding estimating and reporting water supply availability and other data. Any future revisions to 31 TAC 357 adopted by the TWDB may result in a changes to these planning guidelines.

Included in this document are sections covering the following tasks as specified in statute and agency rules:

- 1) planning area description [31 TAC §357.7(a)(1)];
- 2) population and water demand projections [31 TAC §357.7(a)(2)];
- 3) water supply analysis [31 TAC §357.7(a)(3)];
- 4) identification, evaluation, and selection of water management strategies based on needs [31 TAC §357.7(a)(5-7)]
- 5) impacts of water management strategies on key water quality parameters of the state [31 TAC §357.7(a)(12)], and impacts of voluntary redistributions of water [31 TAC §357.7(a)(8)(g)];
- 6) consolidated water conservation and drought management strategy recommendations [31 TAC §357.7(a)(11) and 31 TAC 357.7(a)(7)];
- 7) description of how regional water plans are consistent with the long-term protection of the state’s water, agricultural and natural resources [31 TAC §357.7(a)(13) and §357.14(2)(C)];

- 8) unique stream segments, reservoir sites and legislative recommendations [31 TAC §357.7(a)(8-9); 31 TAC §357.8; 31 TAC §357.9];
- 9) reporting of water infrastructure financing mechanisms [31 TAC §357.7(a)(14)];
- 10) adoption of regional water plans and public participation [31 TAC §357.11-12]; and
- 11) data reporting requirements and written reports deliverable to the TWDB [31 TAC §357.7 (10)].

1.0 Planning Area Description

For the third round of planning, Task 1 is a relatively limited effort to update planning area descriptions reported in 2006 regional water plans. Planning groups should document substantial changes in any of the following areas:

- wholesale water providers, current water use, and identified water quality problems;
- sources of groundwater and surface water including major springs that are important for water supplies or natural resource protection;
- socioeconomic aspects including information on population, major water demand centers, agricultural and natural resources, and primary economic activities including businesses highly dependent on water resources;
- assessment of current preparations for drought within a regional water planning area;
- summaries of existing regional water plans, recommendations in state water plans, and local water plans;
- identified threats to agricultural and natural resources resulting from water quantity or quality problems related to water supply; and
- information compiled by the TWDB from water loss audits performed by retail public utilities pursuant to [31 TAC §358.6].

2.0 Population and Water Demand Projections

Population and water demand projections from the 2007 state water plan will serve as estimates for the current round of planning; however, the TWDB will consider requests for changes to population and water demand projections if conditions have changed. Entities wishing to revise projections should address their requests through their respective planning group. If the planning group concurs, it will submit requests to the executive administrator of the TWDB. Requests for revisions should be accompanied by supporting data, analyses and documentation. TWDB staff will coordinate reviews of each request with the Texas Commission on Environmental Quality, the Texas Parks and Wildlife Department, and the Texas Department of Agriculture.

Population Projections

To ensure consistency and to maintain public credibility in population projections, population estimates published by the Texas State Data Center will be the primary source of reference for any revision requests, unless planning groups can provide alternate published sources based on a similarly rigorous methodology. In regions where estimates from the Texas State Data Center show that current population growth on a regional level is falling significantly short of growth projected in the 2007 state water plan, some localized adjustments and redistribution of projected populations may be appropriate, but increases to regional totals may not be justifiable.

Some examples of changes to sub-county populations (i.e., cities, utilities or rural areas) projections that may be justifiable include:

- population estimates of the Texas State Data Center, or other credible sources, are greater than projected populations used in the 2007 state water plan for the year 2010;
- population growth rates for a sub-county area as tabulated by the Texas State Data Center over the most recent five years is substantially greater than growth rates reported by the U.S. Census Bureau between 1990 and 2000;
- cities have annexed additional land since the 2000 Census; or
- water utilities have expanded their service areas since last updated by the Texas Commission on Environmental Quality.

Water Demand Projections

Municipal water demands will be adjusted for water user groups with revised population projections. Similarly, if acceptable data sources indicate that a measured gallons per capita per day from years prior to 2000 is more representative of drought of record conditions, the TWDB will consider formal requests for revisions. Entities may also request changes to water demand projections for other water user groups including irrigation, livestock, and manufacturing assuming they provide verifiable supporting data and documentation to their respective planning group and the TWDB. The TWDB is currently engaged in a study with the Bureau of Economic Geology at the University of Texas at Austin to revise and/or verify steam-electric water demands for each planning region. Results of the study should be available by August of 2008; at which time, the TWDB will disseminate results to each planning group for review and comment.

3.0 Existing Water Supplies

Planning groups will reevaluate “existing” water supplies for entities including water user groups and wholesale water providers as defined in statute and administrative rules [31 TAC §357.3(A)(F)].¹ An existing water supply is the volume of water available to water user groups

¹ In addition to material regarding water supplies in this document, planning groups should refer to the TWDB’s “*Guidelines for Regional Water Planning Data Deliverables*” for additional information for estimating existing water supplies.

and wholesale water providers under drought of record conditions taking into account any physical constraints such as transmission or treatment facilities that would limit supplies *and* any legal or policy constraints. An existing supply must be connected meaning that it currently has infrastructure for conveying water to water users, or it is anticipated that it will be accessible and connected by the conclusion of the current planning cycle. An example of supplies that are "non-connected" would include lakes without connecting pipelines. Evaluations should consider surface water and groundwater data from the 2007 state water plan and 2006 regional water plans, data regarding existing water rights, contracts and option agreements, and/or other planning and water supply studies. Water supplies from contracted agreements should be based on the terms of a contract, which may be assumed to renew upon a contract's termination date if contract holders contemplate renewals or extensions. The amount of water available from existing supplies in future decades assumes that current infrastructure for existing water supplies does not change through time. In addition to reporting existing water supply volumes, planning groups must also identify all water sources in a planning region even if such sources are not connected, but are potentially available for use in the future (see the "*Guidelines for Regional Water Planning Data Deliverables*" for further information).

The current infrastructure associated with existing supplies - excluding internal water distribution systems – should be researched to determine how much water a system can transport, pump, and distribute.

Source for existing water supplies may include surface waters such as reservoirs and rivers, groundwater, water reuse, and/or a system of several different sources.

3.1 Surface Water

Planning groups should analyze existing surface water supplies based on firm yield for both reservoirs and surface water diversions. For reservoirs, firm yield is the maximum amount of water a reservoir can provide in a given year during drought of record conditions using reasonable sedimentation rates, and under the assumption that senior water rights holders have their full allotments of water. Planning groups may analyze existing water supplies from reservoirs on operational procedures other than firm yield and may use other methods of determining existing supplies in addition to firm yield with written approval from the TWDB's executive administrator; however, *existing water supply data submitted to the TWDB for incorporation into the state water plan must include firm yield*. Unless the TWDB's executive administrator has approved other models, planning groups should use "Run 3" of Water Availability Models maintained by the Texas Commission on Environmental Quality to estimate firm yields for surface water supplies. The TWDB's executive administrator must approve any modifications to data files used in Water Availability Models for permitted return flows and changed conditions.

When using Water Availability Models for firm yield analyses, the TWDB recommends using an "adding-in" approach where each water right is added into the model one by one beginning with the most senior right. After a water right is added into the model, simulated water supply shortages are evaluated. If a supply shortage exists, the diversion amount of the newly added water right should be reduced until the supply shortage disappears. The next right is added in only when all senior rights have their maximum diversions without supply shortages (capped by their permitted amounts). The process terminates when no further diversions can be added in. If all water rights have been fully satisfied and a given reservoir still has surplus supply, a hypothetical junior water right should be added, using a uniform monthly distribution that reduces

the supply source to zero. The firm yield is the sum of model specified diversions, including extended diversions, of added-in water rights. If applicable, environmental flow requirements including bay and estuary and instream flow requirements should be fully satisfied when modeling add-in water rights.

When simulating firm yields for reservoirs, the following criteria must be met if applicable:

1. inflows to reservoirs are the remainder of naturalized stream flows after upstream senior water rights are met;
2. downstream senior water rights must be met; however, this does not require releases of water from a reservoir unless specifically stated in existing water rights;
3. bay, estuary and instream flow requirements should be fully satisfied if permits authorizing a reservoir include such requirements, or if a simulation is for a new water right or proposed diversion;
4. minimum allowable reservoir levels are the top of dead storage;
5. maximum allowable reservoir levels are the top of water supply storage volume for reservoirs with existing water rights, and special conditions of water rights should be honored (this may result in a different minimum and/or maximum allowable reservoir levels);
6. evaporative losses are based on evaporation rate data that best coincide with the period of record and time steps for inflows;
7. annual water supply demands are constant values in all years, and the distribution of annual demands within a given year are constant in all years and should consider different types of water use expected; and
8. time steps should not exceed one month.

Planning groups may modify input data sets for Water Availability Models to reflect return flows specified in water rights permits and other changed conditions; however, planning groups must provide documentation to the TWDB justifying such changes.

For surface water diversions, planning groups should use “firm diversions,” which are the maximum annual diversions in a given year assuming drought of record conditions using reasonable diversion distribution patterns and assuming that senior water rights are met. These amounts should not exceed the infrastructure’s diversion capacity and permit amounts. As is the case with reservoirs, planning groups should use Water Availability Models (Run 3) for surface water diversions unless the TWDB approves other methods. In addition, the TWDB suggests using the same “adding in” approach for water rights. Firm diversions are the sum of model specified diversions, including extended diversions, of all added-in water rights. Parameters of Water Availability Models should not be altered, and environmental flow requirements, if applicable, should be fully satisfied when modeling hypothetical added-in water rights.

If relevant, when simulating firm diversions the following criteria must be met:

1. inflows to diversion sites are the remainder of naturalized stream flows assuming upstream and downstream senior water rights are met (during times of drought it is possible that senior water rights will be withdrawn to legal limits either for use, sale and/or transfer; nevertheless, if planning groups can provide documentation to the TWDB showing a lower demand than legal maximums, they can modify inputs accordingly);
2. bay and estuary and instream flow requirements should be fully satisfied if permits authorizing diversions include such requirements, or if a simulation is for a new water right or proposed diversion;
3. annual diversion amounts are constant values in all years, and the distribution of diversions within a given year are constant and consider different types of water use expected; and
4. time steps should not exceed one month.

For run-of-the-river diversions, drought periods begin with unappropriated flows in rivers declining significantly from their normal levels, or above and before their full recovery to normal levels or greater. The drought of record is a period that includes record minimum river channel unappropriated monthly flow rates and begins and ends with unappropriated flows at or above normal levels.

For surface waters bordering neighboring states or countries, planning groups should analyze and report available water supplies taking into account existing legal agreements; and for surface water withdrawals that do not require permits, such as domestic and livestock uses, estimate water available under drought of record conditions based on available information.

Each planning group should also provide both a list of water rights associated with existing surface water supplies and the association between these water rights, the sources and the water user groups, and in what amounts. All water used by a water user group must be attributed to one or more existing water supplies and all surface water supplies must be associated with applicable water rights. When water rights are consolidated into one existing surface water supply per basin, a water right included in the consolidation should not also be listed as a right for another existing water supply source. Water rights cannot be counted more than once as a source for an existing supply.

Existing supplies from run-of-river diversions are based on the diversion point or on an aggregate of diversions. List the county-basin of the source diversion point. Run-of-river diversions can be aggregated into a combined run-of-river diversion source type if the aggregated water rights are individually less than 10,000 acre feet for irrigation or individually less than 1,000 acre feet for other use categories. Do not list water rights within aggregated run-of-river diversion source types individually. List run-of-river diversions as individual water rights for irrigation permits equal to or greater than 10,000 acre feet. For all other water uses list the individual water rights if the permit is equal to or greater than 1,000 acre feet. All other run-of-river diversions may be listed as individual water rights.

For unpermitted supplies, list the source as the sum of unpermitted surface water in the county-basin. Unpermitted supplies may be listed individually as well.

3.2 Groundwater

For groundwater supplies, planning groups should calculate the greatest annual amount of water available from an aquifer without violating the most restrictive physical and/or regulatory conditions limiting withdrawals under drought-of-record conditions. Regulatory conditions refer to limits on water withdrawals imposed by groundwater conservation districts. When estimating groundwater supplies, planning groups should use TWDB Groundwater Availability Models if available unless better site specific information is accessible. As is the case with surface water supplies, planning groups should document and justify other methods used. If groundwater districts within a groundwater management area have determined the desired future condition for their aquifers, and the TWDB has translated desired future conditions into an estimated managed available groundwater as of January, 1st 2008; then planning groups must use these estimates as the basis for existing groundwater supplies.

3.3 Systems

Water supplies can be categorized as systems if they meet one or more of the following criteria: 1) a source includes groundwater and surface water; 2) several reservoirs operate together, but supplies from a specific reservoir cannot be tracked directly to an end user; and/or 3) two or more reservoirs operate as a system resulting in a system gain in firm yield. System gain is the amount of water a system creates that would otherwise be unavailable if the reservoirs were operated independently. For multi-reservoir systems, the minimum system gain during drought-of-record conditions can be considered additional water available. Total existing water from a system should not exceed the sum of the firm yields of individual reservoirs in a system. Planning groups must adequately describe methods used to calculate system gains. Where special conditions exist, such as in the Rio Grande Project, planning groups may base existing water supplies on operational procedures rather than firm yield. Planning groups must adequately describe special conditions other than the Rio Grande Project in submitted scopes of work. For interstate and international reservoirs, planning groups should report water amounts available to Texas according to existing legal agreements.

3.4 Reuse

Planning groups will quantify existing water supplies from reuse as either direct or indirect. Indirect reuse is process water that reenters rivers or stream systems and is diverted and used again downstream. For indirect reuse, planning groups will use currently permitted reuse projects with infrastructure in place needed to divert and use water in accordance with permits issued by the Texas Commission on Environmental Quality. Potential sources for indirect reuse in the future will require new permits and additional infrastructure. As such, planning groups should consider these as water management strategies, and should explain methods used to estimate the amount of water that such strategies would generate in the future. Direct reuse is process water recirculated within a given system. For direct reuse, planning groups should use the amount of water from direct reuse sources that they expect will be available during drought of record conditions from currently installed wastewater reclamation infrastructure. These amounts should not exceed the amounts of water available to utilities generating the wastewater. Planning groups should treat potential future sources of direct reuse as water management strategies, and should

provide adequate justification to explain methods for estimating the amount of reused water available from such sources.

4.0 Water Management Strategies

Planning groups will reevaluate water management strategies identified in 2006 regional water plans for each water user group and wholesale water provider as defined in statute and administrative rules where future water supply needs exist [31 TAC §357.5-6]. A need for water is present when existing water supplies are less than projected water demands. In addition, each group may recommend new management strategies due to changed physical or socioeconomic conditions. Existing water rights, water contracts, and option agreements should be protected, although amendments to these may be recommended realizing that consent of owners would be needed for implementation. Planning groups will reevaluate and/or evaluate new and existing water management strategies based on criteria specified in [31 TAC §357.7.7-9, 12] including water quantities generated by strategies, the reliability of strategies, financial costs, and environmental impacts. For all strategies identified in 2006 regional water plans, planning groups must update financial costs. For remaining criteria, each planning group will determine if physical and/or socioeconomic conditions have changed enough to warrant a reassessment. For any new strategy recommended, all evaluation criteria must be met.

4.1 Quantity, Reliability and Financial Costs

4.1.1 Quantity and Reliability

Water quantities produced by recommended surface water management strategies will be based on firm yield as defined in Section 3.1; and water quantities generated by groundwater should be based on groundwater availability as defined in Section 3.2.

4.1.2 Financial Costs

Cost evaluations for new and existing water management strategies will include capital costs, debt service, and annual operating and maintenance expenses over the planning horizon. Reported costs will only include expenses associated with infrastructure needed to convey water from sources and treat water for end user requirements; however, reported costs should not include expenses associated with internal distribution networks outside of treatment plants and major transmission facilities. Planning groups must report capital costs and average annual operation and maintenance costs as separate items in the Regional Water Planning Data Web Interface (see the TWDB's "*Guidelines for Regional Water Planning Data Deliverables*" for further information).

Capital Costs

Capital costs consist of construction funds and other capital outlays including, but not limited to, costs for engineering, contingencies, financial, legal, administration, environmental permitting and mitigation, land, and interest during construction. Construction costs, if applicable, should include expenses for the following types of infrastructure:

- pump stations,
- pipelines,
- water intakes,
- water treatment and storage facilities,
- well fields;
- relocation of existing infrastructure such as roads and utilities; and
- any other significant construction costs identified by each planning group.

Interest during construction is based on total project costs drawn down at a constant rate per month during a construction period. Interest is the total interest accrued at the end of a construction period using a 6.0 percent annual interest rate less a 4.0 percent rate of return on investment of unspent funds. Each planning group should adjust construction cost estimates for existing water management strategies based on the most recent price indices for commodities such as cement and steel as reported in the “*Engineering News Record (ENR) Construction Cost Index.*”

If applicable, other capital costs include:

- engineering and feasibility studies including those for permitting and mitigation, legal assistance, financing, bond counsel, and contingencies (engineering, contingencies, financial and legal services should be lumped together and estimated as 30 percent of total construction costs for pipeline projects and 35 percent for other facilities unless more detailed project and/or site specific information is available);
- land and easements costs (easement costs for pipelines should include a permanent easement plus a temporary construction easement as well as rights to enter easements for maintenance); and
- purchases of water rights.

Debt Service

For water management strategies other than reservoirs the length of debt service is 20 years unless otherwise justified. For reservoirs, the period is 40 years. Level debt service applies to all projects, and the annual interest rate for project financing is 6.0 percent. Terms of debt service will be reported in the TWDB’s Regional Water Planning Data Interface.

Annual Operating and Maintenance Costs

Operations and maintenance costs should be based on the quantity of water supplied. Unless project specific data are accessible, planning groups will calculate annual operating and maintenance costs as 1.0 percent of total estimated construction cost for pipelines, 2.5 percent of estimated construction costs for pump stations, and 1.5 percent of estimated construction costs for dams. Costs include labor and materials required to maintain projects such as regular repair and/or replacement of equipment. Power costs are calculated on an annual basis using calculated horsepower input and a power purchase cost of \$0.09 per kilowatt hour; however, each planning group may adjust this figure based on local and regional conditions if they specify and document their reasons. Planning groups should include costs of water if water management strategies involve purchases of raw or treated water on an annual basis (e.g. leases of water rights).

4.2 Environmental Impacts

Planning groups will evaluate and provide a quantitative reporting of how water management strategies could affect environmental and cultural resources including impacts to environmental water needs, wildlife habitats, cultural resources, and the effects of upstream development on the bays, estuaries, and arms of the Gulf of Mexico. Planning groups are free to develop and document an overall methodology for evaluating impacts; however, for environmental flows, planning groups should use site specific studies when available. If such studies are not available, then planning groups should use the 1997 “*Consensus Criteria for Environmental Flow Needs*” for strategies involving surface water development and those requiring permits from the Texas Commission on Environmental Quality. These criteria were developed through extensive collaboration among scientists and engineers from the state’s natural resource agencies including the TWDB, the Texas Parks and Wildlife Department, and the Texas Commission on Environmental Quality, as well as academic professionals, engineering consultants, and informed members of the public. More specifically, the criteria are multi-stage rules for environmentally safe operation of impoundments and diversions during above normal flow conditions, below normal flow conditions, and during drought of record conditions. Documentation describing the methodology and its application is available at the TWDB’s website: <http://www.twdb.state.tx.us/RWPG/twdb-docs/env-criteria.htm>.

4.3 Alternative Water Management Strategies

A list of recommended alternative water management strategies will be included in regional water plans along with each strategy’s name, an expected implementation date, water amounts generated by each strategy on decadal basis and capital costs need to implement the given strategy. All alternative water management strategies must be evaluated based on criteria specified in [31 TAC §357.7, 9, 12].

Planning groups may substitute an evaluated alternative water management strategy for a strategy previously recommended, if the previously recommended strategy is no longer feasible. Proposed alternatives should not result in water supplies that exceed 125 percent of identified water needs for a given water user group for which an alternative is recommended taking into account other strategies already recommended for the same water user group. Planning groups must submit proposed alternative strategies to the TWDB for approval by the executive administrator. If a planning group can demonstrate that there is good cause for a requested alternative to exceed the 125 percent limit, then the executive administrator may issue a written waiver.

5.0 Impacts of Water Management Strategies on Key Water Quality Parameters in the State and Impacts of Moving Water from Agricultural and Rural Areas

Each planning group must describe how implementing recommended and alternative water management strategies could affect water quality in Texas. Planning groups should base water quality impacts on parameters important to water uses in each region. Planning groups will also discuss how water management strategies could affect: 1) agricultural resources including

analyses of third-party impacts of moving water from rural and agricultural areas; 2) water resources of the state including ground and surface water interrelationships; and 3) other factors deemed relevant by planning groups such as recreational impacts. Furthermore, planning groups should consider statutory provisions regarding interbasin transfers of surface water [(TWC §11.085(k)(1)]. At minimum, considerations should include a summation of water needs in basins of origin and receiving basins based on water needs in approved regional plans.

6.0 Water Conservation and Drought Management Recommendations

When evaluating and recommending water management strategies, each planning group will consider “active” water conservation as potentially feasible water management strategies for water user groups for which [TWC §11.127] applies and must consider active water conservation strategies for water user groups with needs. Active water conservation strategies are those that conserve water over and beyond what would happen anyway as result of “passive” water conservation measures that stem from federal and state legislation requiring more efficient plumbing fixtures in new building construction. If a planning group does not adopt active water conservation strategies to meet needs, they must document their reasons. In addition, planning groups should include active water conservation strategies for water user groups or wholesale water providers that will obtain water from new interbasin transfers.

Planning groups must also consider drought management strategies for identified water needs, and whenever applicable, drought management strategies should be consistent with guidance provided by the Texas Commission on Environmental Quality [TWC §11.1272]. Drought management strategies decrease short-term peak water requirements. Strategies for drought management are similar to those for water conservation, although there are some basic differences. For example, water conservation and drought management strategies differ in their longevity. Water conservation strategies are generally implemented on a permanent basis, whereas drought management practices are implemented during times of severe drought or other emergencies that can limit water supplies. If a planning group does not select drought management as a water management strategy, they must document the reason.

7.0 Descriptions of how Regional Water Plans are Consistent with the Long-term Protection of the State's Water, Agricultural and Natural Resources

Planning groups should describe how regional water plans are consistent with the long-term protection of Texas' water, agricultural and natural resources including the requirement that planning analyses and recommendations honor all existing water rights and contracts. Although much of the analysis pertaining to this requirement will be developed for other tasks including tasks associated with estimating the environmental and water quality impacts of water management strategies, planning groups are encouraged to identify the specific resources important to their planning areas and describe how these resources are protected through the regional water planning process.

8.0 Unique Stream Segments and Reservoir Sites and Other Legislative Recommendations

8.1 Unique Stream Segments

Planning groups may recommend all or parts of river and stream segments in their respective regions as having "unique ecological values." To recommend a designation, planning groups must justify it based on the following criteria:

- biological function measured as stream segments displaying significant habitat value including both quantity and quality considering degrees of biodiversity, age, and uniqueness including terrestrial, wetland, aquatic, or estuarine habitats;
- hydrologic function measured as stream segments fringed by habitats that perform valuable hydrologic functions relating to water quality, flood attenuation, flow stabilization, or groundwater recharge and discharge;
- riparian conservation areas measured as stream segments fringed by significant areas in public ownership including state and federal refuges, wildlife management areas, preserves, parks, mitigation areas, or other areas held by governmental organizations for conservation purposes, or stream segments fringed by other areas managed for conservation purposes under governmentally approved conservation plans;
- high water quality, exceptional aquatic life, high aesthetic value and spring resources that are significant due to unique or critical habitats and exceptional aquatic life uses dependent on or associated with high water quality; or
- threatened or endangered species and unique communities defined as sites along streams where water development projects would have significant detrimental effects on state or federally listed threatened and endangered species, and sites along streams significant due to the presence of unique, exemplary, or unusually extensive natural communities.

Planning groups seeking a designation should forward a recommendation package to the Texas Parks and Wildlife Department, who will in turn provide a written evaluation of the

proposal within 30 days. Packages should contain a description of a site's location along with maps, photographs, and documentation with supporting literature and data that characterizes a site's unique ecological value. Adopted regional water plans should include, if available, the Texas Parks and Wildlife Department's written evaluation.

If the Texas Legislature designates a stream or river segment as unique; or if a planning group recommends that a stream or river segment be classified as unique, each planning group must quantitatively assess how recommended water management strategies in a regional plan would affect flows deemed important (by planning groups) to the stream or river segment in question. Furthermore, assessments should describe how a regional plan would affect the unique features cited by a region as the impetus for a legislative designation.

8.2 Unique Reservoir Sites

Planning groups may recommend sites for reservoir construction that have "unique value" by including a description of the site, reasons for the unique designation and expected beneficiaries of water supplies developed at a given site. The following criteria should be used to determine if a site is unique:

- site specific reservoir development is recommended as a specific water management strategy or as an alternative long-term scenario in an adopted regional water plan; or
- factors such as location, hydrologic, geologic, topographic, water availability, water quality, environmental, cultural, and current development characteristics make a site uniquely suited for either reservoir development to provide water supply for the current planning period; or where it might reasonably be needed to meet water needs beyond the 50-year planning period.

8.3 Other Legislative Recommendations

Planning groups may compile regulatory, administrative, or legislative recommendations that will facilitate the orderly development, management, and conservation of water resources in Texas, and will help the state prepare for and respond to droughts. In addition, they may develop information regarding the potential impacts of recommendations enacted into law once proposed changes are in effect.

9.0 Reporting of Financing Mechanisms for Water Management Strategies

Planning groups will assess how local governments, regional authorities, and other political subdivisions would finance the implementation of water management strategies via a formal survey administered by the TWDB and executed by each planning group. The TWDB will develop a survey instrument and methodology. Each planning group will conduct a survey and report findings to the TWDB. The TWDB will provide additional instructions and documentation describing the survey methodology and formats for reporting resultant data.

10) Adoption of Plan and Public Participation

Planning groups will adopt regional plans and allow for public participation in the plan adoption process in accordance with administrative rules and statute and allow for public participation.

11.0 Deliverables

11.1 Written Reports

Planning groups will update the contents of 2006 regional water plans with new information and analyses conducted as part of the current planning cycle. As was the case for the last planning cycle, initially prepared and adopted regional water plans or amendments to approved regional water plans should include a technical report containing chapters describing each task summarized in this document; and an executive summary documenting key findings and recommendations that does not exceed 30 pages. Appendices deemed appropriate by planning groups may also be included.

In addition, each regional water plan must include in its chapter describing water management strategies (Task 4) a list of all potentially feasible water management strategies, and all recommended water management strategies including their names, implementation dates, water amounts by decade, and capital costs. Similarly, each regional water plan must report in the same chapter all alternative water management strategies (as described in Section 4.5 of this document) considered for substitution listing the same criteria. Other documentation should include: 1) model water conservation plans pursuant to [TWC §11.1271]; 2) model drought contingency plans pursuant to [TWC §11.1272]; and 3) summaries of written and oral comments from the public during the plan adoption process with responses by planning groups explaining how plans were revised or why changes were not warranted.

11.2 Regional Water Planning Data Reporting

Planning groups must submit data generated or updated during the current round of planning to the TWDB in accordance with TWDB specifications *prior to* submitting initially prepared regional water plans. Data must be entered through the TWDB's Regional Water Planning Data Web Interface at <http://www.twdb.state.tx.us/apps/db12>. Specifications regarding data requirements, format, calculation and composition are available on the TWDB's website.

ANNEX 2:
Cost Estimation Procedures
for the South Central Texas
Region (Region L)
[Provisional]

Section 5

Cost Estimating

Although the engineering focus of this report is on the hydraulic analysis of pumping stations and pipelines, the cost estimating procedures presented apply to all components that may be included in an alternative. Other items that may be part of a study are water treatment plants, reservoirs, and groundwater wells to name a few. The cost estimate for an alternative can be prepared once all pertinent data is gathered and sizing of any pipelines and pumping stations is complete.

A studies level cost estimate includes three major cost categories: construction costs or capital costs, other project costs, and annual costs. Construction costs are the direct costs, such as those for materials, labor, and equipment, incurred in constructing facilities. These are the costs that are submitted by a contractor bidding on a project. “Other project costs” include additional expenses not directly associated with construction activities of the project such as costs for engineering, land acquisition, contingencies, studies, and interest during construction. Capital costs and other project costs comprise the total project cost. Operation and maintenance (O&M), energy costs, and debt service payments are examples of annual costs. Major components that may be part of a preliminary cost estimate are listed in Table 5-1.

Cost estimating at the studies level involves the determination of a new alternative cost or updating an existing alternative cost to a specific time period. Determining the preliminary cost of a new project alternative may involve a preliminary hydraulic analysis and identification of the desired project elements and location. From this information, the project costs are developed by the three major categories outlined earlier. Updating the costs of existing alternatives from one time period to another or possibly updating the cost of an existing alternative element and combining it into a new one involves applying a factor based on the *Engineering News Record* (ENR) *Construction Cost Index* (CCI), to the **capital costs**. The “other project cost” items, such as land costs and interest during construction should be updated using actual current values (land price estimates, interest rates, etc.) rather than applying an escalation factor.

**Table 5-1.
Major Project Cost Categories**

Cost Elements	
Capital Costs (Structural Costs)	Other Project Costs (Non-Structural Costs)
1. Pump Stations	1. Engineering (Design, Bidding and Construction Phase Services, Geotechnical, Legal, Financing, and Contingencies)
2. Pipelines	2. Land and Easements
3. Water Treatment Plants	3. Environmental - Studies and Mitigation
4. Water Storage Tanks	4. Interest During Construction
5. Off-Channel Reservoirs	
6. Well Fields	
a. Public	
b. Irrigation	
c. ASR Wells	
7. Dams and Reservoirs	
8. Relocations	
9. Water Distribution System Improvements	
10. Other Items	
	Annual Project Costs
	1. Debt Service
	2. Operation and Maintenance (excluding pumping energy)
	3. Pumping Energy Costs
	4. Purchase Water Cost (if applicable)

The following guidelines should be followed to estimate the capital cost for each component of a project alternative, as well as other project costs, and annual costs. Keep in mind that an alternative may require an element that is not adequately addressed in these guidelines. This type of situation will require that the costs for the element be handled on an individual basis and will involve research to determine an appropriate cost. **Note that the following guidelines have been left in general terms. Specific cost information for Senate Bill 1 work, such as finance interest rates can be found in Appendix B.**

5.1 Capital Costs

Capital costs for an element that is part of a new study are determined from reliable cost information. Construction cost information can be obtained from a number of sources, such as the following: vendor catalogs, construction periodicals, commercial cost reference materials, digests of actual project costs, text books, and cost tables based upon historical data from actual projects. At the studies level, cost tables are the most useful reference for determining the costs for a project element quickly and efficiently. Cost tables that have been created for HDR studies

level cost estimates are discussed and presented later in this section. The cost for a project element can be determined by applying a unit cost from the cost tables to a specific unit quantity. For example, reservoir costs may be determined by acre-foot of capacity and pipeline costs can be determined by pipe diameter and linear feet of line. Cost estimates are approximate, therefore reporting costs to the dollar is not necessary. Estimates reported to the thousands of dollars are acceptable. If the cost data is not current, an ENR CCI ratio can be applied to update the cost to the desired time period. Equation 5-1 is used to update **capital costs** using the appropriate cost index values which can be found in the most recent Engineering News Record publication of the construction cost index values, or on the internet at <http://www.enr.com/cost/costcci.asp> under the Construction Cost Index History (1908-Present). ENR CCI values are reported monthly, and there is also an average index value calculated for each year. To get an index value that represents a specific period of a year, an average index number can be calculated using the values in that same time period. For example, based on the index values within the 2nd quarter of 2007 (7865, 7942, 7393) the representative **Second Quarter 2007-index** value would be **7733**. Additionally, future ENR CCI values can be estimated based on percentages of monthly or yearly change in the indices.

$$\text{Updated Capital Cost} = \text{Outdated Capital Cost} * \left(\frac{CCI_{\text{updated time period}}}{CCI_{\text{outdated time period}}} \right) \quad (5-1)$$

Existing studies will require a cost update if changes have been made to the fundamental characteristics of project elements or project operation. Examples include be an increase in the volume of water being pumped or pumping to a different delivery location. Such changes may require that alternatives be updated using many of the same steps that would be performed for a new study cost estimation. For example, the hydraulic analysis of a pump station and pipeline may have to be redone to determine proper sizes for handling a change in flow rate. A more appropriate capital cost can then be estimated. If there are no major changes to the alternative, then the CCI ratio can be applied to capital costs to update them to the time period desired.

5.1.1 Cost Data

The cost tables provided within this report are the first source for a studies level cost estimate. Cost tables in this section can be used to determine construction cost estimates for most of the major components that will be encountered on a studies level alternative. The cost tables report “all-inclusive” costs to construct a particular facility. For example, the pump station cost table values include building, pump, control equipment, materials, labor, and installation costs. Interpolation between the table values may be necessary in order to arrive at the appropriate cost estimate. Each cost table will have a reference time period for which the cost data is current. An ENR CCI ratio should be used to update the cost table values to the time period selected for the study. Additional resources are available to estimate the cost of system components not adequately addressed by the cost tables.

The *Means Heavy Construction Cost Data* and *Means Building Construction Cost Data* reference manuals contain detailed costs for various components and building activities. These references report material, labor and equipment costs as well as total costs including overhead and profit. The total cost including overhead and profit is the value that should be used for an estimate. These costs, however, should be adjusted to the proper geographic location of the project using Means’ geographic adjustment factors. The values may be used as is, or modified based upon judgment for use in the alternative. The *Dodge Manual for Building Construction* also provides similar information.

Bid tabulations are another valuable resource of construction cost data. Bid tabulations are summaries of actual bid costs prepared by contractors bidding on a construction project. The costs reported include materials, installation, overhead and profit. Since bidding is a competitive aspect of construction, the resulting bids can vary significantly in the costs of various components. Judgment should be exercised in using bid prices. It is advisable to review the prices of the three lowest bids for a project before choosing a price based on bid tabulations. Other sources for bid or actual project costs include: The *Dodge Digest of Building Costs and Specifications*, which provides descriptions of design features, and costs for actual projects by building type; and the *Engineering News Record*, which publishes bid prices of projects chosen from all types of construction projects. **All sources of cost data should be well documented and referenced.**

5.1.2 Pumping Stations

Anticipated pump and booster station costs vary according to the discharge and pumping head requirements, and structural requirements for housing the equipment and providing proper flow conditions at the pump suction intake. For studies level costing estimates the cost tables provided are based on the station size, or horsepower, for the **peak flow rate**. The costs are listed as millions of dollars in Table 5-2 for a particular horsepower. The costs include those for pumps, housing, motors, electric control, site work, and all materials needed. The costs in Table 5-2 were estimated using generalized cost data related to station horsepower from actual construction costs of equipment installed. Costs for pump stations that are part of water treatment plants are accounted for in the capital cost table for water treatment plants (Table 5-6).

Table 5-2.
Pumping Station Costs* (With and Without Intake Structures)

Pump Station (HP)	Pump Station Cost (\$-millions)	Pump Station (HP)	Pump Station Cost (\$-millions)
< 300	0.97	6,000	7.99
300	0.97	7,000	8.84
400	1.21	8,000	9.69
1,000	2.42	9,000	10.53
2,000	4.00	10,000	11.14
3,000	5.33	15,000	14.17
4,000	6.42	20,000	17.19
5,000	7.14	> 20,000	See Note
Values are current as of 2nd Quarter 2007.			
NOTE: Pump Stations larger than 20,000 HP necessitate an individual cost estimate.			

Other capital costs are to be calculated and added to the pumping station costs from Table 5-2 to get a total pumping station facility cost. Additional costs for a PUMP station are those for an intake structure, if needed, and for bringing electrical power to the pump station. BOOSTER station total costs will include the power connection costs as well as costs for a ground storage tank (Section 5.1.6).

Raw water may be pumped from a river, lake or reservoir. Pumping water from any surface water source will require the construction of an intake structure to divert water from the

source to the pumping facility. There are a wide variety of intake structure and pumping facility arrangements possible. For example, intakes may be placed in a deep point in a lake, near a shoreline in shallow water, or directly on shore with an excavation to deeper water. The pumping facilities may be built in the intake structure or located remotely. The land and water environment dictate the option selected for implementation. Based on costs of actual projects, the intake structure cost can be estimated using Equation 5-2.

$$\text{Intake Structure Cost} = 50\% * \text{Pump Station Cost (at Intake)} \quad (5-2)$$

The cost of bringing electrical power to each pump station can be a significant cost and needs to be accounted for. Factors that influence the power connection costs include the distance to the nearest power source and the electrical demand of the pumping station. Equation 5-3 accounts for both factors and should be used to estimate the power connection cost for each pump and booster station. Power connection costs will also be calculated for wells which will be discussed in Section 5.1.9.

$$\text{Power Connction Cost} = \frac{\$135}{1\text{HP}} * \text{Station Horsepower, with } \$50,000 \text{ minimum per station} \quad (5-3)$$

5.1.3 Pipeline

Pipeline construction costs are influenced by pipe materials, bedding requirements, geologic conditions, urbanization, terrain, and special crossings. For a studies level cost estimate, pipeline costs will be determined from Table 5-3 which shows unit costs based on the pipe diameter, soil type, and level of urban development. **In the case of a high-pressure pipeline (>150psi), the pipe unit cost should be increased by 13 percent for the length of pipe designated as high pressure class pipe.** The unit costs listed in Table 5-3 include installed cost of the pipeline and appurtenances, such as markers, valves, thrust restraint systems, corrosion monitoring and control equipment, air and vacuum valves, blow-off valves, erosion control, revegetation of rights-of-way, fencing and gates.

In order to determine the cost of a pipeline that runs though several different types of soil, the unit cost is adjusted based upon the relative percentage of soil composition and development

conditions. The soil composition alternatives given in Table 5-3 are soil, rock, and a combination of soil and rock. County soil surveys and geologic maps, as discussed in Section 3.1.1, are good references for determining the soil type along a pipeline route. Development conditions are defined as either urban, which refers to areas in or around cities and towns, or as rural which refers to all other areas. Equation 5-4 is an example of how to adjust the pipeline unit cost for various soil conditions. Constructing pipelines in rocky areas can significantly increase the project costs. Using the results of Equation 5-3, the total pipeline cost is equal to the total pipeline length multiplied by the adjusted unit cost (Equation 5-5).

$$\begin{aligned} \text{Adjusted Pipeline Unit Cost} &= (\% \text{ of Pipe in Soil}) * (\text{Unit Cost for Pipe in Soil}) \\ &+ (\% \text{ of Pipe in Rock}) * (\text{Unit Cost for Pipe in Rock}) \\ &+ (\% \text{ of Pipe in Comb. Soil}) * (\text{Unit Cost for Pipe in Comb. Soil}) \end{aligned} \quad (5-4)$$

$$\text{Total Pipeline Cost} = (\text{Adjusted Unit Cost}) * (\text{Total Pipeline Length}(ft)) \quad (5-5)$$

Another approach is to multiply the unit cost for a soil and development condition by the corresponding length of pipeline, and then sum the costs for each.

$$\text{Total Pipeline Cost} = \sum (\text{Pipe Unit Cost} * \text{Corresponding Pipe Length}(ft)) \quad (5-6)$$

There will be additional costs for pipeline installation when crossing roads, streams or rivers. This is discussed further in Section 5.1.4. **Note that the length used to estimated pipeline costs should be reduced by the amount length required for any horizontal directional drill crossings as the cost tables for this construction method includes the cost for pipe.**

**Table 5-3.
Pipeline Unit Cost within Various Soil Environments***

Pipe Diameter (inches)	Soil		Combination Rock and Soil		Rock	
	Rural (\$/ ft)	Urban (\$/ ft)	Rural (\$/ ft)	Urban (\$/ ft)	Rural (\$/ ft)	Urban (\$/ ft)
12	45	72	56	87	68	101
14	50	82	64	98	77	114
16	56	92	72	111	85	127
18	63	101	81	121	95	138
20	66	108	85	130	100	148
24	74	122	95	147	113	167
27	85	140	108	166	129	190
30	97	156	121	184	145	214
33	113	182	140	216	167	250
36	129	206	161	246	190	285
42	163	263	202	314	245	364
48	201	326	250	391	303	453
54	243	398	304	474	366	550
60	288	470	361	561	433	649
64	320	522	400	621	482	720
66	337	550	424	658	509	761
72	390	633	486	755	583	876
78	446	722	547	862	668	1,001
84	506	817	630	975	756	1,131
90	570	924	711	1,102	855	1,279
96	637	1,037	800	1,238	961	1,415
102	708	1,153	887	1,374	1,061	1,593
108	783	1,273	981	1,518	1,176	1,764
114	861	1,400	1,076	1,671	1,292	1,937
120	943	1,535	1,181	1,829	1,417	2,123

* Values as of 2nd Quarter 2007.
Add 13 percent to unit price for length of pipe with pressure class > 150 psi.

5.1.4 Boring, Tunneling, and Horizontal Directional Drill Crossings

It is inevitable that pipeline routes will intersect obstacles to construction along the route. Pipelines are typically installed by open cut construction if no obstacles are encountered. Open cut construction entails digging a trench from the surface, installing sections of pipe and fittings, and backfilling the trench. Open cut techniques can probably be used for crossing dry, intermittent, and minor creeks and streams, dirt roads, and other minor roads. The unit costs shown in Table 5-3 include an allowance for open-cut crossings. Some form of trenchless technology will probably be used to install the pipeline when obstructions such as larger streams, major roads, railways, rivers, and structures are met. Trenchless technology may also be used to avoid buried utilities. Construction methods vary in scale and complexity, but in general, trenchless construction involves tunneling beneath an obstacle or structure and installing the pipeline in the tunnel, while leaving an obstacle or structure undisturbed. Trenchless technologies that will most likely be used as part of a studies level analysis are boring and/or tunneling techniques to excavate the soil and horizontal directional drilling. Trenchless construction should be used for most major streams, all rivers, all US and state highways, all paved county roads not considered to be minor, and all railways.

Most pipeline crossings at roads and railways can be installed using boring or tunneling excavation methods. Normally a casing pipe is installed in the excavated opening either by jacking the pipe in place or by hand installation of the pipe. Pipe jacking is a method of using hydraulic rams to push pipe sections to a desired alignment. The excavation method used is dictated by the diameter of the hole and the costs for construction. Excavation for smaller diameter pipe is usually accomplished by boring a hole with some type of auger equipment. At larger diameters, which are considered to be “man entry” size (≥ 42 -inch diameter), hand digging may be more cost effective due to the increasing size and cost of tunneling equipment required to produce the required hole diameter. When soil conditions are suitable, larger diameter casings (> 48 -inches) may be installed using hand excavation and installation of corrugated steel plate segments (tunnel liner plate) to form a circular tunnel.

A typical road or railway crossing involves digging pits on both sides of the obstacle. One pit serves as the launching pit and the other is the receiving pit. Nearly all crossings of highways, roads, and railroads require a casing pipe to be installed to protect the road or railway in the event of water leakage or blowout of the water carrying pipe. There are practical limits to this type of construction, for example the maximum practical length of a single span pipe jacking

is about 500 feet, and the suggested maximum depth is 15 feet. These values could possibly be exceeded, but at an increase in construction costs. There are no theoretical restrictions on the diameter of pipe that can be installed, but it should be noted that standard tunnel liner plate assemblies are available in diameters from 4-feet through 15-feet.

During the design phase of a project, permits for crossings will have to be prepared which describe the proposed crossing in detail. The agency that has jurisdiction over the obstacle being crossed will have unique requirements regarding length of the bore, type of casing pipe and so on. At this level of analysis there is no need to investigate permit requirements for pipeline borings. The number of borings and the estimated length of each pipe size used are needed to help produce the construction cost estimate. The estimated lengths for each crossing will vary and require some judgment in determining what length is adequate. Table 5-4 lists lengths that can be used as a guide, and Table 5-5 shows suggested costs that can be used to estimate pipeline crossings. The costs shown in Table 5-5 include the total costs for boring or tunneling, casing, and other incidental costs for the carrier pipe diameters shown.

**Table 5-4.
Suggested Crossing Lengths**

Obstacle Requiring Boring	Suggested Bore Length (feet)
Two-lane County Road	115
Railway	100
Four-Lane Divided Highway ¹	210
6-Lane Divided Highway ^{1,2}	234 or more
Others	As required
1 Assumes 12' lane width, 9' shoulders (4 total), 66' median, and bore extending 30' from outside shoulder edge. 2 Major highway widths can well exceed this value. The highway may be abutted by frontage/access roads, and the median may be wider to accommodate future expansion, both of which would add to the length of the crossing	

**Table 5-5.
Crossing Costs with Boring or Tunneling Construction***

Pipe Diameter (inches)	Tunneling Cost (\$/inch diameter/ft)
≤ 48	23
54	22
60	21
66	20
72	19
78	18
≥ 84	17
* Values current as of 2 nd Quarter 2007.	

Occasionally, more significant obstacles along the pipeline route, such as rivers or major highway interchanges, will be encountered. These types of obstacles will also require trenchless construction. Due to increased depth and/or possibly the width of the obstacles, horizontal directional drilling techniques may be the method used for pipeline installation. **HDR has predetermined that crossings of the Colorado, Guadalupe, San Marcos, and Brazos Rivers should utilize the directional drilling methods. Construction methodology to be used on other potential crossings should be evaluated on an individual basis.** The process of directional drilling starts with drilling a hole from the ground surface at a prescribed entry angle from horizontal and continuing under and across the obstacle along a design profile made up of straight tangent sections and a long radius arc. Successive reams may be required to produce the correct diameter hole. Once the hole is large enough a “pipe string”, which is usually the carrier pipe but can be casing pipe, is pulled into position in the hole.

Directional drill costs are usually based on the horizontal length of the drill and the type of pipe. For our purposes, we will assume that steel pipe will be used. The length of the directional drill is based on the entry and exit angles, the radius of curvature, and the minimum depth required to cross under the obstacle. A general rule of thumb for the radius of curvature is 100 feet per 1-inch diameter for steel line pipe. Typically, 20 feet is used for clearance under most rivers, other obstacles may require a different clear distance. Horizontal directional drilling can be used to install pipe up to a maximum diameter of 48-inches. If the transmission line is significantly larger, say a 96-inch line, three options are available: install the largest pipeline that

can be installed and include the additional head losses, install parallel lines, or use a different construction methodology for the crossing. A typical horizontal directional drill profile, based on a circular arc, is shown in Figure 5-1. The variables shown in Figure 5-1 can be used for estimating the length of a horizontal directional drill and are defined as follows:

R = Radius of Curvature = Radius for a Circle Using a Circular Arc

R = Maximum Of :

$$= (100 \text{ FT/inch diameter}) * (\text{Pipe Diameter in inches}) \quad (5-7)$$

OR

$$= \frac{\text{TD}}{1 - \cos \Delta/2}$$

D = Depth From Ground Surface Where Drill Starts to Bottom of Obstacle

CD = Clear Distance From Obstacle Bottom (20 FT)

$$\text{TD} = \text{Minimum Total Depth of the Horizontal Directional Drill} = D + CD \quad (5-8)$$

$\frac{\Delta}{2}$ = Entry/Exit angle from horizontal. Angles from 8 to 20 degrees can be used for most directional drill crossings. For studies purposes, use 12 degrees. (5-9)

$$= \cos^{-1} \left(1 - \frac{\text{TD}}{\text{R}} \right)$$

LC = Long Chord = horizontal distance of the directional drill (5-10)

$$= 2R \sin(\Delta/2)$$

$$L = \text{Arc Length} = \frac{2(\Delta/2)\pi R}{180} \quad (5-11)$$

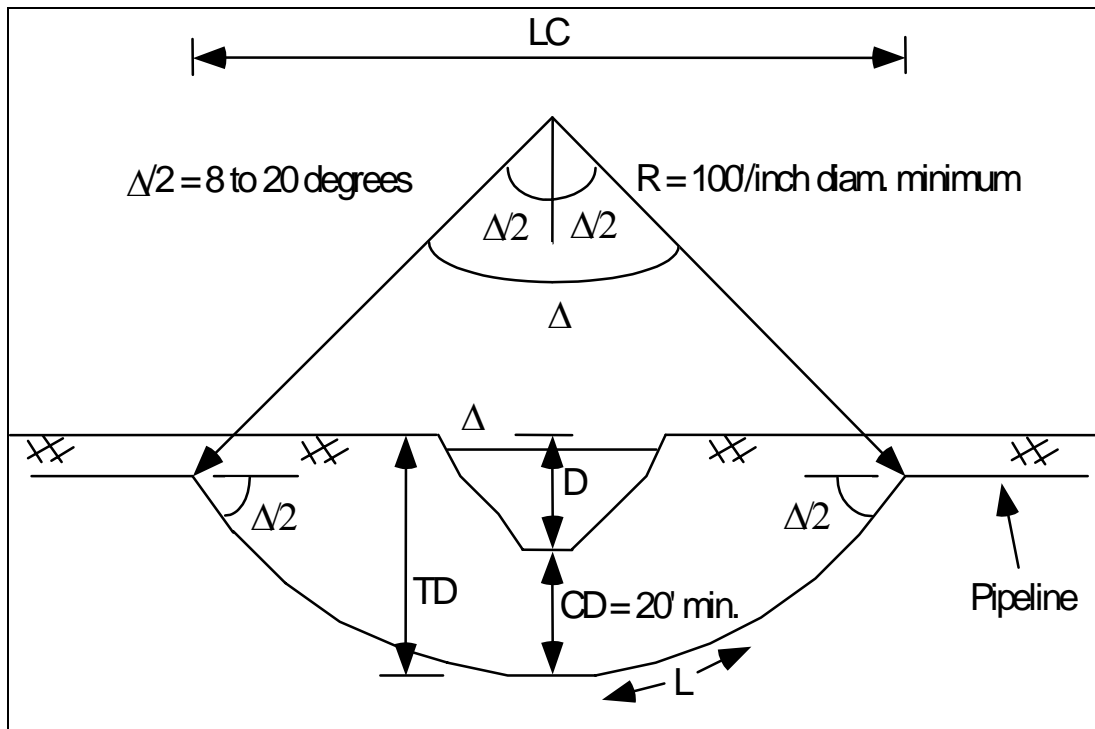

Figure 5-1. Typical Horizontal Directional Drill Profile

Based on the variables from Figure 5-1, lengths and costs for different diameters of horizontal drill crossings have been estimated and are shown in Table 5-6. Use of the table requires that the minimum total depth (TD, Equation 5-8) needed for the crossing be estimated. The depth from the ground surface where the drill starts to the bottom of the obstacle, “D”, can be estimated using topographic maps. **The costs in Table 5-5 include pipe costs, therefore, the pipeline costs developed from Table 5-3 should be based on the length of the pipe less the length for horizontal directional drill crossings.**

**Table 5-6.
Horizontal Directional Drilling Costs and Lengths***

Table 5-6a – Estimated Length of HDD Boring (feet)

Total Depth (feet)	Pipe Diameter				
	24"	30"	36"	42"	48"
30	1,600	1,700	1,900	2,100	2,200
40	1,800	2,000	2,200	2,400	2,500
50	2,000	2,200	2,400	2,600	2,800
60	2,300	2,400	2,700	2,900	3,100
70	2,700	2,700	2,900	3,100	3,300
80	3,100	3,100	3,100	3,300	3,500
90	3,500	3,500	3,500	3,500	3,800
100	3,900	3,900	3,900	3,900	3,900

Table 5-ba – Unit Costs for Directional Drilling (\$/ft of Pipe "L")

Soil Type	Pipe Diameter				
	24"	30"	36"	42"	48"
Soil	\$200	\$250	\$350	\$500	\$700
Rock	\$300	\$413	\$600	\$863	\$1,200

Table 5-6c – Estimated Cost for Directional Drilling - Soil

Total Depth "TD" (feet)	Pipe Diameter				
	24"	30"	36"	42"	48"
30	\$320,000	\$424,915	\$665,000	\$1,049,806	\$1,540,000
40	\$360,000	\$499,900	\$770,000	\$1,199,778	\$1,750,000
50	\$400,000	\$549,890	\$840,000	\$1,299,760	\$1,960,000
60	\$460,000	\$599,880	\$945,000	\$1,449,732	\$2,170,000
70	\$540,000	\$674,865	\$1,015,000	\$1,549,714	\$2,310,000
80	\$620,000	\$774,845	\$1,085,000	\$1,649,695	\$2,450,000
90	\$700,000	\$874,825	\$1,225,000	\$1,749,677	\$2,660,000
100	\$780,000	\$974,805	\$1,365,000	\$1,949,640	\$2,730,000

Table 5-6d – Estimated Cost for Directional Drilling - Rock

Total Depth "TD" (feet)	Pipe Diameter				
	24"	30"	36"	42"	48"
30	\$480,000	\$701,301	\$1,140,000	\$1,811,373	\$2,640,000
40	\$540,000	\$825,060	\$1,320,000	\$2,070,141	\$3,000,000
50	\$600,000	\$907,566	\$1,440,000	\$2,242,653	\$3,360,000
60	\$690,000	\$990,072	\$1,620,000	\$2,501,421	\$3,720,000
70	\$810,000	\$1,113,831	\$1,740,000	\$2,673,932	\$3,960,000
80	\$930,000	\$1,278,843	\$1,860,000	\$2,846,444	\$4,200,000
90	\$1,050,000	\$1,443,855	\$2,100,000	\$3,018,956	\$4,560,000
100	\$1,170,000	\$1,608,867	\$2,340,000	\$3,363,979	\$4,680,000

*Notes: Length calculated using maximum of 12 degree entrance angle and 100 x pipe diameter as radius of curvature. Factor of safety of 2 applied to length. Values current as of 2nd Quarter 2007.

5.1.5 Water Treatment Plants

Construction costs for water treatment facilities can be estimated using Table 5-7. The costs shown are based on plant capacity for four different types of water treatment. It is not the intent of the cost estimating methodology to establish an exact treatment process but rather to estimate the cost of a general process appropriate for bringing the source water quality to the required standard of the receiving system; i.e., potable water distribution system, a stream in an aquifer recharge zone, or an aquifer injection well. The process options presented include Carrizo water treatment (ground water), simple filtration, conventional treatment, and reclaimed wastewater treatment. Treatment level 1 (Carrizo) is a process used to lower the iron and manganese content, to disinfect and to treat for taste and odor within groundwater. Level 2 treatment, simple filtration, will be used for treating waters to be injected into an aquifer or delivery to a recharge zone from sources with low anticipated turbidity, odor, taste and color. Level 2 treatment also includes iron and manganese removal. Treatment level 3 is conventional treatment used for treating all surface water sources to be delivered to a potable water distribution system. Treatment level 4 is a process where wastewater effluent is to be reclaimed and delivered to a supply system or injected into an aquifer. Table 5-8 gives a thorough description of the processes involved in each treatment option. The costs in Table 5-7 include costs for all processes required, site work, buildings, storage tanks, sludge handling and disposal, clearwell, pumps and equipment. The costs assume pumping through and out of the plant as follows: Levels 2, 3, & 4 treatment plants include raw water pumping into the plant for a total pumping head of 100 feet, and finished water pumping for 300 feet of total head. Level 1 treatment includes finished water pumping only at 300 feet of head.

**Table 5-7.
Water Treatment Plant Costs**

Capacity (MGD)	Level 0	Level 1	Level 2	Level 3	Level 4	Level 5	Level 6
	Capital Cost (\$)	Capital Cost (\$)	Capital Cost (\$)	Capital Cost (\$)	Capital Cost (\$)	Capital Cost (\$)	Capital Cost (\$)
1	55,940	728,912	3,692,993	4,160,490	7,799,117	2,736,447	4,334,726
10	168,788	3,033,461	9,928,461	16,151,457	30,331,462	14,469,269	22,509,096
50	497,888	8,810,150	25,094,192	54,631,115	93,885,333	53,360,725	82,698,832
75	666,676	12,711,041	32,317,081	78,382,631	129,994,936	76,487,339	120,597,419
100	822,266	15,573,292	38,382,671	95,010,666	173,326,097	100,727,904	156,377,074
150	1,108,746	23,832,278	49,648,843	142,513,699	259,988,540	147,683,405	227,536,816
200	1,372,946	27,443,057	55,426,985	175,766,742	346,652,194	194,021,389	297,522,065

* Values current as of 2nd Quarter 2007

**Table 5-8.
Water Treatment Level Descriptions**

Level 0:	Disinfection Only - This treatment process will be used for groundwater with no contaminants that exceed the regulatory limits. Assumes groundwater does not require treatment for taste and odor reduction and groundwater is stable and requires no treatment for corrosion stabilization. With this treatment, the ground water is suitable for public water system distribution, aquifer injection, and delivery to the recharge zone.
Level 1:	Ground Water Treatment - This treatment process will be used for groundwater to lower the iron and manganese content and to disinfect. The process includes application of an oxidant and addition of phosphate to sequester iron and manganese. Chlorine disinfection as the final treatment. With this treatment, the ground water is suitable for public water system distribution, aquifer injection, and delivery to the recharge zone.
Level 2:	Direct Filtration Treatment - This treatment process will be used for treating ground water from sources where iron, manganese, or other constituent concentrations exceed the regulatory limit and require filtration for solids removal. Assumes turbidity and taste and odor levels are low. In the direct filtration process, low doses of coagulant and polymer are used and settling basins are not required as all suspended solids are removed by filters. The process includes alum and polymer addition, rapid mix, flocculation, filtration, and disinfection. Water treatment with this process is suitable for aquifer injection or for delivery to the recharge zone.
Level 3:	Surface Water Treatment - This treatment process will be used for treating all surface water sources to be delivered to a potable water distribution system. The process includes coagulant and polymer addition, rapid mix, flocculation, settling, filtration, and disinfection with chlorine. This treatment process also applies for difficult to treat groundwater containing high concentrations of iron (greater than 3 mg/l) and manganese requiring settling before filtration.

Level 4:	Reclaimed Water Treatment - This process will be used for treatment where wastewater effluent is to be reclaimed and delivered to a supply system or injected to an aquifer. The concept includes increased treatment of wastewater effluent by phosphorous removal, storage in a reservoir, blending with surface runoff from the reservoir catchment, followed by conventional water treatment. Phosphorous will be removed from the effluent by lime softening including lime feed, rapid mix, flocculation, settling, recarbonation, and filtration. The final treatment assumes ozonation, activated carbon, addition of coagulant and polymer, rapid mix, flocculation, sedimentation, second application of ozone, filtration and disinfection with chlorine. This treatment results in water that can be delivered to a public water system for distribution or injection to the aquifer.
Level 5:	Brackish Groundwater Desalination - Note: This treatment cost does not include pretreatment for solids removal prior to RO membranes. For desalination of a surface water or groundwater containing high solids concentrations, additional solids removal treatment should be included in addition to desalination. (Example: add level 3 treatment costs for a turbid surface water source). This treatment process will be used for treatment of groundwater with total dissolved solids (TDS) exceeding the regulatory limit of 1,000 mg/l. Costs are based on reverse osmosis (RO) membrane desalination of a groundwater with 3,000 mg/l of TDS to lower the treated water TDS below the regulatory limit. The desalination concept includes minimal pretreatment (cartridge filtration, antiscalent addition, acid addition), reverse osmosis membrane system, and disinfection with chlorine. Costs assume desalination concentrate will be discharged to surface water adjacent to treatment plant. With this treatment, the ground water is suitable for public water system distribution, aquifer injection, and delivery to the recharge zone.
Level 6:	Seawater Desalination - Note: This treatment cost does not include pretreatment for solids removal prior to RO membranes. For desalination of a surface water or groundwater containing high solids concentrations, additional solids removal treatment should be included in addition to desalination. (Example - For desalination of seawater with an intake located on the coast drawing turbid water, cost estimate should include Level 3 treatment plus Level 6). This treatment process will be used for treatment of seawater with total dissolved solids (TDS) exceeding the regulatory limit of 1,000 mg/l. Costs are based on reverse osmosis (RO) membrane desalination of a water with 32,000 mg/l of TDS to lower the treated water TDS below the regulatory limit. The desalination concept includes minimal pretreatment (cartridge filtration, antiscalent addition, acid addition), reverse osmosis membrane system, and disinfection with chlorine. Costs assume desalination concentrate will be discharged to surface water adjacent to treatment plant. With this treatment, the ground water is suitable for public water system distribution, aquifer injection, and delivery to the recharge zone.
Source: Trans-Texas Study	

5.1.6 Storage Tanks

Ground storage tanks may be used for stand-alone storage, as part of a distribution system, or as part of a pumping station. The costs for storage tanks are listed in Table 5-9 as cost per million gallons of capacity. A storage tank should be included at each booster station along a pipeline. **For study purposes it is assumed that storage tanks at booster stations will provide storage for 5 percent of the daily flow.**

**Table 5-9.
Storage Tank Costs¹**

Table 5-9a – Ground Storage Tanks

Tank Volume (MG)	Cost (\$)
0.01	20,584
0.05	71,438
0.10	121,082
0.50	411,678
1.00	702,274
2.00	1,186,601
4.00	2,058,390
6.00	2,784,880
7.50	3,269,207
9.00	3,753,534
¹ Values current to 2 nd Quarter 2007.	

Table 5-9b – Elevated Storage Tanks

Tank Volume (MG)	Cost (\$)
0.05	266,380
0.10	319,656
0.15	372,932
0.20	426,208
0.25	492,803
0.30	532,760
0.40	639,312
0.50	705,907
0.60	806,404
0.75	932,329
1.00	1,166,017
¹ Values current to 2 nd Quarter 2007.	

Elevated storage tanks are rarely used in water transmission systems. Typically, they are utilized in distribution systems within a water service area. If elevated storage tanks are to be used in an alternative, the costs should be researched on an individual basis.

5.1.7 Off-Channel Reservoirs

An off-channel reservoir is a reservoir located on a tributary to, or away from, a main river channel that receives little or no natural inflow. Off-channel reservoirs are built by placing a dam across a minor tributary or constructing a ring dike that has no associated tributary. The capacity of these reservoirs is typically used for storing water that is pumped from another location, such as a nearby river. Because natural inflow is an insignificant factor, spillway works will be minimal. Table 5-10 should be referenced for a cost estimate for an off-channel reservoir.

Table 5-10.
Off Channel Storage Costs*

Storage Volume (ac-ft)	Ring Dike Capital Cost (\$)¹
500	\$4,601,200
1,000	\$6,538,500
2,500	\$10,776,300
4,000	\$13,803,400
5,000	\$15,740,700
10,000	\$22,763,400
12,500	\$25,548,300
15,000	\$28,212,100
17,500	\$30,754,800
19,000	\$32,450,000
20,000	\$33,297,500
22,000	\$35,113,800
25,000	\$37,535,400

5.1.8 Well Fields

While many water suppliers rely solely on surface water, there are a number of suppliers that rely solely on groundwater, or that supplement surface water supplies with groundwater. As such, groundwater continues to be a potential water source considered for irrigation and/or public supply.

Wells must be constructed to extract water from below the land surface and pump it into a water delivery system. Each well can be thought of as an individual, or stand alone, pump station for sizing purposes and for pumping energy calculations. Size/horsepower requirements, like pump stations, are based on the flow and the total dynamic head. Total dynamic head for a well pump is the elevation difference between the hydraulic grade line and the estimated groundwater surface at the well during pumping conditions, plus station losses. This water reference water surface elevation is the static water elevation below the land surface less the amount of draw down due to pumping.

For our purposes three types of wells may be evaluated at the studies level; public supply, irrigation, and aquifer storage and recovery (ASR). Public supply wells are wells used by municipalities and other water suppliers to supply groundwater for consumption. Irrigation wells provide water for irrigation purposes but may also be used in scenarios involving surface and groundwater exchange. ASR is the concept of using wells to inject water into an aquifer for temporary storage and then extracting the water later when needed. ASR wells include injection wells, recovery wells, and wells that can be used for both injection and recovery.

Well costs have been generated for the different types of wells in for pumping water from various static water level ranges. Table 5-11a shows the costs for public wells at a certain depth and flow for a particular static water table. Table 5-11b shows costs for irrigation wells will be estimated as 55% of the costs for public supply wells. Table 5-12 shows the costs for ASR wells. The costs in Tables 5-11 and 5-12 are for the complete installation of the well and pump to include drilling services, materials, pump and control equipment, valves, testing, security fencing, and a small access road. The costs do not include those for a building, surface piping connecting to a transmission/collector pipeline, or power connection costs. **Power connection costs will need to be estimated for wells and well fields using Equation 5-3 to get a total well/well field capital cost.** For wells that have significant spacing, say 1-mile apart or more,

the power connection cost will likely be \$50,000 per well, unless the horsepower requirement is large enough to have the \$135/HP unit cost control. For wells that are constructed close to one another in clusters, the power connection cost could be \$50,000 per well cluster, unless the \$135/HP unit cost controls for the cluster.

**Table 5-11.
Public and Irrigation Well Costs**

Table 5-11a: Public Supply Well Costs

Well Depth (ft)	Well Capacity (gpm)					
	100	175	350	700	1000	1800
150	\$100,498	\$152,563	\$260,326	\$294,229	\$366,878	\$536,392
300	\$135,612	\$193,731	\$309,969	\$354,770	\$438,316	\$621,149
500	\$175,569	\$242,163	\$368,089	\$423,786	\$521,862	\$722,858
700	\$211,893	\$285,753	\$420,154	\$486,749	\$596,933	\$812,459
1000	\$278,488	\$365,667	\$517,019	\$601,776	\$736,177	\$979,551
1500	\$389,883	\$500,068	\$676,847	\$794,296	\$966,232	\$1,255,618
2000	\$501,278	\$633,258	\$836,675	\$986,816	\$1,197,498	\$1,532,895

Values current as of 2nd Quarter 2007.

Table 5-11b: Irrigation Well Costs

Well Depth (ft)	Well Capacity (gpm)					
	100	175	350	700	1000	1800
150	\$55,698	\$85,968	\$146,509	\$168,304	\$213,104	\$307,548
300	\$73,860	\$110,184	\$179,201	\$211,893	\$268,801	\$375,353
500	\$92,022	\$138,033	\$214,315	\$259,115	\$329,342	\$454,057
700	\$106,552	\$158,617	\$244,585	\$299,072	\$382,618	\$521,862
1000	\$139,244	\$204,628	\$307,548	\$381,407	\$487,959	\$655,053
1500	\$194,942	\$283,331	\$411,678	\$518,230	\$662,317	\$875,421
2000	\$249,428	\$359,613	\$515,808	\$653,841	\$837,886	\$1,097,001

Values current as of 2nd Quarter 2007.

**Table 5-12.
ASR Well Costs**

Well Depth (ft)	Well Capacity (gpm)					
	100	175	350	700	1000	1800
150	\$111,395	\$171,936	\$299,072	\$337,818	\$421,364	\$621,149
300	\$146,509	\$213,104	\$348,715	\$398,359	\$492,803	\$707,117
500	\$186,466	\$262,747	\$406,835	\$467,376	\$577,560	\$807,615
700	\$224,001	\$306,337	\$460,111	\$530,338	\$651,420	\$898,427
1000	\$289,385	\$386,251	\$555,765	\$645,366	\$790,664	\$1,064,309
1500	\$401,991	\$519,441	\$715,593	\$837,886	\$1,020,719	\$1,340,375
2000	\$512,176	\$652,631	\$875,421	\$1,030,406	\$1,251,985	\$1,617,652

Values current as of 2nd Quarter 2007.

5.1.9 Dams and Reservoirs

Reservoirs, other than off-channel reservoirs, are those constructed by building a dam across a river or major tributary. The reservoir storage capacity, in addition to flood storage, is filled mainly by the natural inflow. Many studies may involve dams and reservoirs that have been previously costed. If this is the case, the capital cost can be updated using the ENR CCI ratio. Cost estimates for dams that have not been previously costed should be prepared on an individual project basis. Since each reservoir site is unique, new reservoir costs will be based on specific requirements of the project for the site. Cost estimates for these structures will involve determining approximate material volumes (soil, rock, concrete, etc.) that will be used, and an estimate of the cost for the spillway, outlet works, and other structures. Material quantities can be computed by using the average end method. Relocation cost of utilities, roads, railroads, and other features should be included in the cost estimate. Environmental, mitigation, and land costs will also have to be addressed.

5.1.10 Relocations

Large-scale projects, such as reservoirs, may require the use of lands that contain existing improvements or facilities such as homes, businesses, utilities, and roads. If the benefits outweigh the costs, the new project element may be constructed, but with the requirement that selected affected improvements or facilities be relocated. An example of a relocation is the rerouting of a highway out of the inundation area of a new reservoir. Table 5-13 lists unit costs that can be used for road relocations. Because the type of improvements and facilities that may be candidates for relocation can vary significantly, estimating the costs for other relocation items will be handled on an individual basis.

**Table 5-13.
Suggested Road Relocation Costs***

<i>Relocation</i>	<i>Unit Cost</i>
Highways	
2-lane Asphalt (44ft section)	\$250/LF
4-lane Asphalt (88ft section)	\$500/LF
County Roads	
Asphalt Road	\$200/LF
Gravel Road	\$130/LF
Private Gravel Road	\$55/LF
Bridges	\$55/SQ FT
Rail	
Railway	\$350/LF
Railway Bridge	\$7,500/LF
* Based on HDR experience and research.	

5.1.11 Water Distribution System Improvements

The introduction of treated water to a city, or other entity, may require improvements to the entity's water distribution system. The distribution system is comprised of piping, valves, storage tanks, pump stations, and other equipment used to distribute water through the entity's service area.

A detailed analysis of a distribution system is needed to determine the system improvements required to handle the introduction of additional water supplies. The analysis would incorporate the development of a model of the entity's distribution system using a program, such as KYPIPE or EPANET, to determine what improvements are needed. This level of work is usually beyond the scope of a studies level analysis.

Cost estimates for distribution system improvements should be handled on an individual basis because the magnitude of improvements needed will vary significantly with each system. Some systems may actually require very little improvements, while others may require large-scale advancements.

Capital cost guidelines (2nd quarter of 2007) have been developed specifically for distribution system improvements **for the City of San Antonio ONLY** and are as follows:

$$\frac{\$1,327,000}{\text{MGD}} \text{ for the first 50 MGD of increased water supply, and} \quad (5-12)$$

$$\frac{\$819,000}{\text{MGD}} \text{ for the increased water supply beyond 50 MGD}$$

An example calculation for estimating the capital cost for distribution system improvements for an increased water supply of 66.4 MGD is shown.

EXAMPLE:

$$(50 \text{ MGD}) * \frac{\$1,327,000}{\text{MGD}} = \$66,350,000$$

$$(16.4 \text{ MGD}) * \frac{\$819,000}{\text{MGD}} = \$13,431,600$$

$$\text{Total Capital Cost} = \$79,781,600$$

5.1.12 Stilling Basins

If an alternative involves discharging into a water body or perhaps into a recharge structure, it may require that excess energy in the water be dissipated so that scouring and erosion do not become a problem. Energy will be dissipated with the use of stilling basins. Stilling basin costs can be estimated for flows of 100 cfs or less using Equation 5-13. Costs for stilling basins that handle flows greater than 100 cfs should be handled on an individual basis.

$$\text{Stilling Basin Cost}_{2\text{nd Quarter } 2007} = \$3,025 * Q(\text{cfs}) \quad (5-13)$$

5.1.13 Other Capital Cost Items

Alternatives may involve elements that are not adequately addressed by the cost tables and guidelines within this section. These additional items will require research on an individual basis to obtain appropriate cost estimates.

5.2 Other Project Costs

As previously mentioned, “other project costs” are costs incurred in a project that are not directly associated with construction activities. These include costs for engineering, legal, financing, contingencies, land, easements, environmental services, and interest during construction.

5.2.1 Engineering, Legal, Financing, and Contingencies

Some “other project” costs can be estimated by applying a percentage to the total capital cost. For studies level cost estimates we will use a percentage to calculate a combined cost that accounts for engineering, financial, and legal services, and contingencies. The contingency allowance accounts for unforeseen circumstances and for variances in design elements. **The percentages to be used are 30 percent of the total construction costs for pipelines and 35 percent for all other facilities.**

$$\text{Cost} = (\text{Pipeline Capital Cost}) * (0.3) + (\text{Other Facilities Capital Cost}) * (0.35) \quad (5-14)$$

5.2.2 Land Acquisition

Land related costs for a project can typically be divided into two categories, land purchase costs and easement costs. Land purchase costs are those costs incurred for direct purchase of land areas not currently in the project owner’s possession. Generally, all facilities that will be part of a project, except for pipelines, will be built on land owned by the project owner. Survey and legal service costs for land transactions (Section 5.2.3) will be added to land and easement costs to get the total land acquisition costs. One possible exception to this is land leasing that may be used for well fields. Suggested land areas for various facility types are listed in Table 5-14.

**Table 5-14.
Suggested Land Area for Various Facilities**

Facility	Suggested Land Area (acres)
Pump Station	2
Water Treatment Plant ¹	$(Q_{\text{peak MGD}})^{0.6}$
Water Storage Tanks	2
Reservoirs	Inundation Area
Well Fields ²	0.5 per well minimum
1 ASCE "Water Treatment Plant Design, Third Edition" 2 Larger land areas may be required in order to obtain a certain quantity of water rights.	

Pipelines may be built on lands that are, or are not, possessed by the project owner. Typically, a pipeline will start on land in the possession of the project owner that was purchased and/or dedicated for use with a specific facility, such as a pump station or water treatment plant, and then traverse cross-country. Rather than purchase land along the pipeline route, easements are usually acquired. The general definition of an easement is a right granted by the owner of a parcel of land to another party. The rights are for use of the land for a specified purpose. There are a number of easement types and methods in which they can be created. For pipelines, the process is usually similar to land purchase, with a price being paid for construction of the pipeline on the landowner's property and for future entry rights for maintenance activities. Payment for easements may be less than land purchase price since the original owner maintains title, and the land is usually restored after construction by the contractor, and used by the landowner.

Two types of easements are usually acquired for pipeline construction, temporary and permanent. Permanent easements are those, in which the pipeline will reside once constructed, and provide room for future maintenance and protect the line from other parallel underground utilities. Temporary easements provide extra working space during construction for equipment movement, material storage, and related construction activities. Once the pipeline has been installed, the grounds are restored to pre-construction conditions, and the temporary easement ceases to exist. The owner of the property may resume activities over the easements, with the right granted to the project owner allowing entry to the permanent easement for inspection, maintenance, and repair activities. Table 5-15 Lists suggested easement widths for various pipe

diameters and number of lines. The total construction easement width shown is the sum of the permanent and temporary easements.

Table 5-15.
Suggested Pipeline Easement Widths

Pipe Size and Number	Permanent Easement Width (ft)	Total Construction Easement Width (ft)
≤ 36" Diameter, Single Line	30	100
≤ 36" Diameter, Two Lines	40	100
> 36" Diameter, Single Line	40	150
>36" Diameter, Two Lines	50	150

Land costs vary significantly with location and economic factors. Land costs in Texas can be estimated using Rural Land Values in the Southwest, by Charles E. Gilliland, published biannually by the Real Estate Center at Texas A&M University. Land values are estimated by county and land type. The information in this publication can also be found on the Internet at <http://recenter.tamu.edu/Data/datar1.html>, (current at the time this manual was printed). Other sources of land values, such as county appraisal district records, may be available for use. Some judgement in the use of suggested land costs is required. For example, the land cost estimate developed from a resource may be appropriate for general land prices but may not be appropriate for prime locations in the same area. In such a situation, the prime land value could be significantly higher than that of the surrounding lands. To determine land purchase costs, apply a determined land value to the total land area needed for the project facilities (Equation 5-15).

$$\text{Land Cost} = \text{Land Area}(\text{acres}) * \text{Land Value}(\$/\text{acre}) \quad (5-15)$$

Equation 5-16 will be used to estimate pipeline easement costs for studies. The costs generated by Equation 5-16 should be adequate to include costs for the temporary easements. The permanent easement acreage can be calculated using equation 5-17.

$$\begin{aligned} \text{Permanent Easement Cost} &= \text{Easement Area}(\text{acres}) * \left(\frac{\$8,712}{\text{acres}} \right) \\ &= \text{Easement Area}(\text{ft}^2) * \left(\frac{\$0.20}{\text{ft}^2} \right) \end{aligned} \quad (5-16)$$

$$\text{Perm. Easement (acres)} = \text{Perm. Easement Width (ft)} * \text{Line Length (ft)} * \frac{1 \text{ acre}}{43,560 \text{ ft}^2} \quad (5-17)$$

The land area recommended in Table 5-14 for well fields is considered the minimum area needed for constructing, operating, and maintaining each well. In Texas, groundwater rights are tied to land ownership/control, therefore water rights may be obtained through land purchase or leasing arrangements. Groundwater usage, however, may be regulated to some degree by local entities. Regulations may stipulate a maximum quantity of water that can be developed per acre of land controlled. In this case, the regulations would dictate the land area to be purchased or leased for the well field. If the land is purchased, the project owner will then “own” the associated water rights. If the well field land is leased, the project owner would pay for leasing the land and then likely be assessed a royalty payment for the water developed (considered an annual cost).

5.2.3 Surveying and Legal Fees

Surveying and legal services are required with most land transactions. For our purposes, we will estimate the fees for these services and add them to land and easement costs to get a total land acquisition cost.

Ten percent (10 percent) should be added to the total land and easement costs to account for surveying and legal fees associated with land acquisition, except for reservoirs. The surveying cost for reservoirs is estimated as \$50 per acre of inundation.

5.2.4 Environmental and Archaeology Studies, Permitting, and Mitigation

In general, most construction projects will require some type of approval by governmental agencies. Environmental permits may be required by local, state, and/or the federal agencies for projects that affect land and water resources, or generate air pollution. Of particular importance, studies for projects will be performed to determine if environmentally sensitive areas, wetlands, threatened or endangered species, and valuable archaeological/cultural resources exist on or near properties where project facilities are proposed for construction. In

addition to potentially requiring permits by regulating agencies, such conditions may result in restrictions or modifications in construction, may require mitigation, and in some cases could prevent construction altogether. The definition of mitigation is to alleviate or make milder. As related to construction projects, mitigation refers to actions taken to achieve equitable compensation given for environmental impacts relative to construction and/or operation of the project. This could include purchase of land, enhancement of wildlife habitat and/or money compensation.

Environmental and archaeological studies are usually performed during the design phase of a project, though some investigations may occur during the preliminary engineering phase. In the studies level analysis of a project, it is difficult at best to determine what permits may be required and the costs for environmental studies. There will be some base fee for the initial environmental studies that will be performed on a project. More detailed environmental analysis may be required if any environmental issues are discovered, which could result in increased environmental studies and permitting costs, and perhaps mitigation. Mitigation, if required, can vary significantly, as would the related value/cost. Costs for environmental studies, permitting, and mitigation are project dependent and should be estimated on an individual basis using information available and the judgment of qualified professionals. Equation 5- 18 can be used as a starting point for estimating the environmental and mitigation costs for all project components except pipelines. The environmental studies and mitigation costs for pipelines should be estimated as \$25,000/mile of pipeline.

$$\text{Environmental/Mitigation Costs} = \text{Land Cost} \times 100 \text{ percent} \quad (5-18)$$

5.2.5 Interest During Construction

An entity generally funds construction projects by securing loans or selling bonds of some type. Typically, the entity receives the funds at the start of the construction project and pays the contractor from the funds over the duration of the construction period. Interest on the borrowed funds will be charged during the construction period as well. It is desired by the entity not to make payments on the borrowed funds or the interest until the project is complete and is generating revenue. As such, the interest during construction (IDC) is determined and treated as a cost item to be included as part of the total project cost and made part of the loan. In addition,

the entity may invest part of the borrowed funds during the construction period and any gains made on the investments can be used to offset interest payments (i.e. reduce the net interest during construction).

IDC is calculated as the cost of interest on the borrowed amount less the return on the proportion of borrowed money invested.

IDC is calculated by applying the net interest rate over the construction period of the project to the average project cost (Equation 5-19). The net interest rate is the interest rate on borrowed funds less the return interest rate from the investment on unspent borrowed funds. The average project cost is equal to the sum of the capital costs, and all other project costs, excluding IDC, divided by two.

$$\text{IDC} = [\text{Amount Borrowed} \times \text{Annual Rate of Loan} \times \text{Construction Period (years)}] - [\text{One-Half Amount Borrowed} \times \text{Annual Rate of Return} \times \text{Construction Period (years)}] \quad (5-19)$$

The final total project cost is equal to all costs plus the interest during construction.

5.3 Annual Costs

The annual costs in a cost estimate are the estimated annual costs that the project owner can expect if the project is implemented. These costs include the costs for repayment of borrowed funds (debt service), operation and maintenance costs of the project facilities, pumping power costs, and possibly water purchase costs.

5.3.1 Debt Service

Debt service is the estimated annual payment that can be expected for repayment of borrowed funds based on the total project cost (present worth), the project finance rate, and the finance period in years. These are uniform payments that include both interest and principle. Debt service is expressed in economic terms in Equation 5-20. This equation is summarized as “Find A Given P”, where “A” is the annual payment and “P” is the present worth. Equation 5-21 is the same equation but uses the terms related specifically to the project.

$$\text{Annual Payment} = \text{Present Worth} \times \text{Uniform Payment Series Capital Recovery Factor} \quad (5-20)$$

$$\text{Debt Service} = \text{Total Project Cost} \times \text{Uniform Payment Series Capital Recovery Factor} \quad (5-21)$$

The uniform payment series capital recovery factor can be determined one of two ways. It can be calculated using Equation 5-22, where i is the finance interest rate and N is the number of interest periods (i.e. the finance period or length of debt service in years).

$$\text{Uniform Payment Series Capital Recovery Factor} = \frac{i(1+i)^N}{(1+i)^N - 1} \quad (5-22)$$

The uniform payment series capital recovery factor can also be determined by using tables of compound interest factors that are found in most engineering economic textbooks. The factors will be listed under some reference to finding “A given P” and are usually grouped by interest rate and then listed by the number of interest periods. The values for the factor should be equivalent using either methods. For example, the debt service factor at 6% for 30 years is 0.07265 and 0.06646 at 6% for 40 years.

5.3.2 Operation and Maintenance

Operation and maintenance costs for dams, pump stations, pipelines and well fields (excluding pumping power costs) include labor and materials required to maintain the project, regular repair and/or replacement of equipment. **Operation and maintenance costs (O&M) are calculated as 1 percent of the total estimated construction costs for pipelines, distribution, tanks and wells, as 1.5 percent of the total estimated construction costs for dams and reservoirs and as 2.5 percent for intake and pump stations.**

Water treatment plant O&M is estimated using Table 5-16. The O&M costs listed in Table 5-16 include labor, materials, replacement of equipment, process energy, building energy, chemicals, and pumping energy.

**Table 5-16.
Operation and Maintenance Costs for Water Treatment Plants¹**

Capacity (MGD)	Level 0	Level 1	Level 2	Level 3	Level 4	Level 5	Level 6
	O&M Cost (\$)	O&M Cost (\$)	O&M Cost (\$)	O&M Cost (\$)	O&M Cost (\$)	O&M Cost (\$)	O&M Cost (\$)
1	25,427	145,056	259,963	325,347	505,516	307,548	720,436
10	75,434	808,705	1,082,955	1,271,116	3,755,835	2,385,310	6,320,467
50	283,331	3,033,461	4,621,932	5,199,371	16,610,599	11,151,629	30,548,924
75	409,741	4,621,932	6,932,899	8,089,108	25,999,520	16,563,983	45,563,061
100	534,818	5,704,888	8,810,150	10,110,084	34,664,735	25,959,926	69,864,167
150	781,946	9,243,865	12,999,699	14,443,357	51,997,708	38,612,969	102,798,402
200	1,026,652	10,832,457	17,332,973	18,776,510	69,330,681	51,205,470	135,490,473

* Values current as of 2nd Quarter 2007

5.3.3 Pumping Energy Costs

Power costs are calculated on an annual basis using the appropriate calculated power load and a power rate of \$0.09 per kWh. Refer to Section 4.2 to determine the amount of energy consumed.

$$\text{Annual Power Cost} = (\$0.09 \text{ per kWh}) \times (\text{Energy Consumed per kWh}) \quad 5-23$$

5.3.4 Purchase of Water

The purchase cost, if applicable, should be shown if the alternative involves purchase of raw or treated water from an entity. This cost will vary by source.